

Exhaust Emission Systems

DATSUN 1600 SPORTS TCS SYSTEM

Datsun 1600 Sports (1970)

NOTE - Air Injection is also used with this system.

DESCRIPTION & OPERATION

By-pass valve opens when clutch pedal is not depressed and with transmission in 3rd. or 4th. gear.

Clutch Switch - Switch is actuated by clutch pedal. When clutch pedal is depressed switch is "OFF", when clutch pedal is released switch is "ON".

Transmission Switch - Located on transmission, switch is actuated by fork rod in transmission. When either 3rd. or 4th. gears are engaged, switch is "ON". In any other gear switch is "OFF".

The by-pass valve supplies an air/fuel mixture which maintains proper combustion during periods of deceleration.

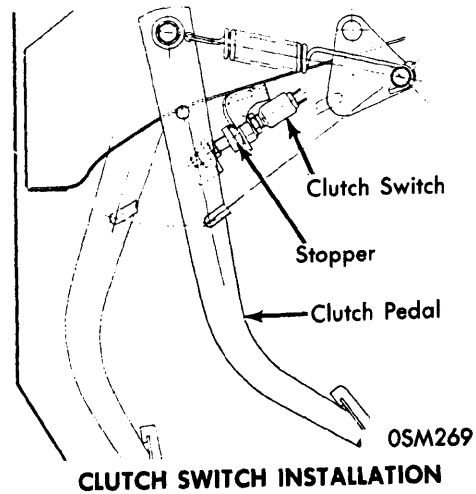

By-pass valve operation

T/M \ Clutch	Engaged	Disengaged
	3rd, 4th	Open
1st, 2nd, neutral reverse	Close	Close

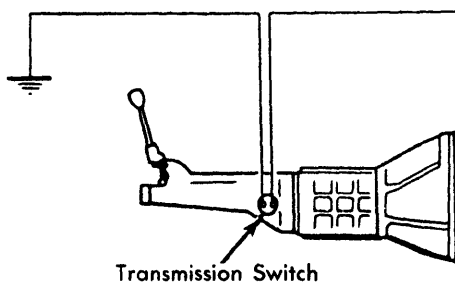
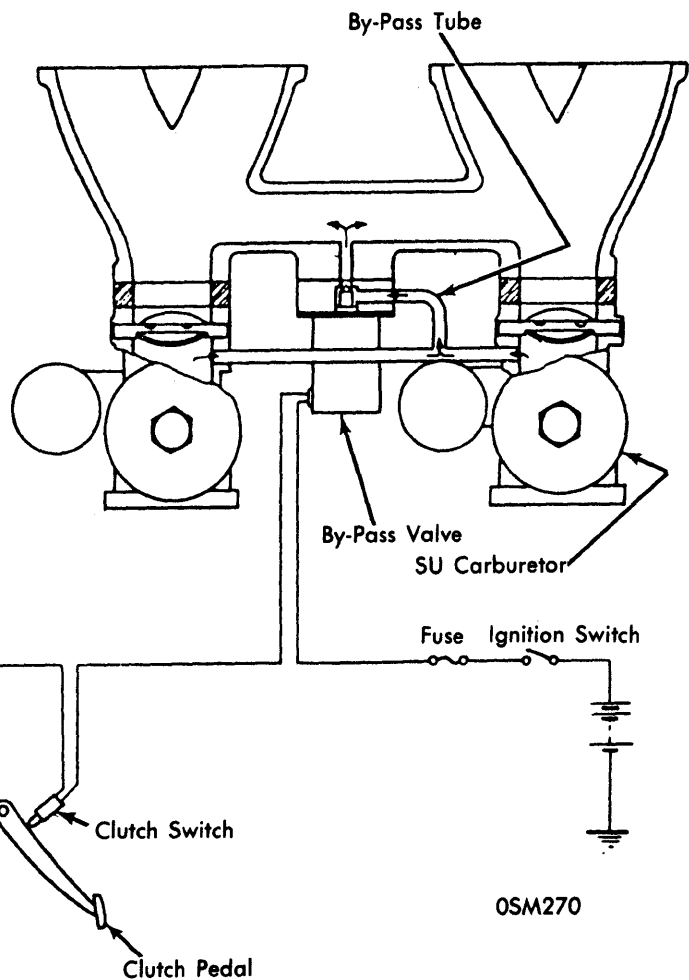

CONTROL SYSTEM SCHEMATIC