

Crankcase Ventilation

TOYOTA CLOSED

- Carina (2T-C Engine)
- Celica (8R-C & 18R-C Engine)
- Corolla (K, K-C, 3K-C & 2T-C Engine)
- Corona (3R-C, 8R-C & 18R-C Engine)
- Corona Mk II (8R-C, 18R-C, 2M & 4M Engine)
- Crown (M, 2M & 4M Engine)
- Hi-Lux Pickup (8R-C & 18R-C Engine)
- Land Cruiser (F Engine)

DESCRIPTION

Toyota uses a "closed" crankcase ventilation system. The "closed" ventilation system consists of a hose connecting the air cleaner and crankcase and a hose connecting the crankcase and intake manifold with a ventilation valve located in it. Hose connections vary with different engine types, see illustrations.

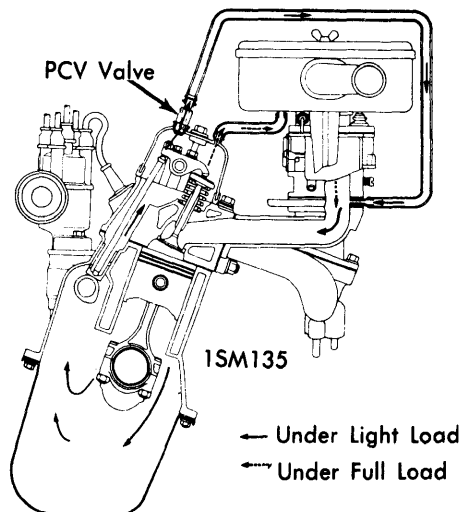

**CRANKCASE VENTILATION SYSTEM
(K, K-C & 3K-C ENGINE)**

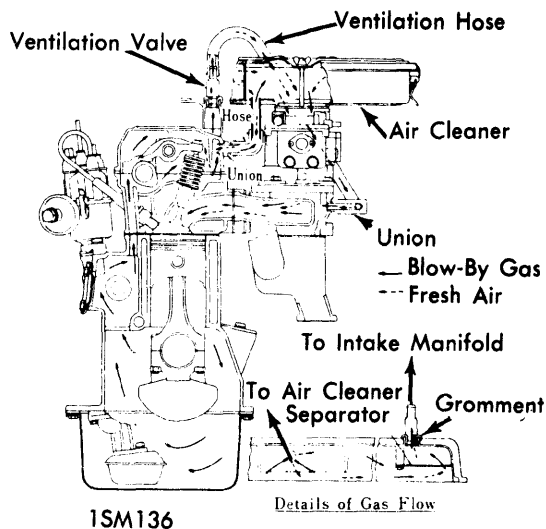

**CRANKCASE VENTILATION SYSTEM
(8R-C & 18R-C ENGINE)**

OPERATION

Air enters system through air cleaner to either cylinder head cover or ventilation tube depending on engine type, see illustrations. Ventilation air mixed with blow-by gases enters ventilation tube into ventilation valve. Ventilation valve regulates amount of air flow to meet the change of operating conditions. The air is then drawn into the intake manifold through a connecting hose where it enters the combustion system and is burned.

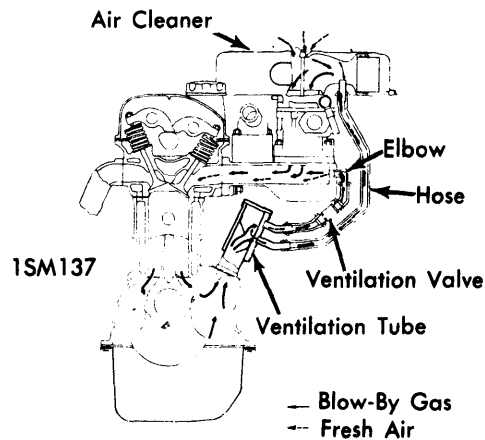

**CRANKCASE VENTILATION SYSTEM
(M, 2M ENGINE)**

Ventilation Valve - Valve is operated by pressure difference between crankcase and intake manifold. When there is no difference of pressure (engine not running) or when pressure of intake manifold is greater than that of crankcase, valve is closed. During engine idle, high intake manifold vacuum overcomes the valve spring and valve is pulled toward intake manifold side by vacuum. This causes air to pass through the restricted passage between valve and housing. During normal engine operation, valve remains in a position where spring pressure and intake manifold vacuum balance. Amount of ventilating air flow then depends upon position of valve.

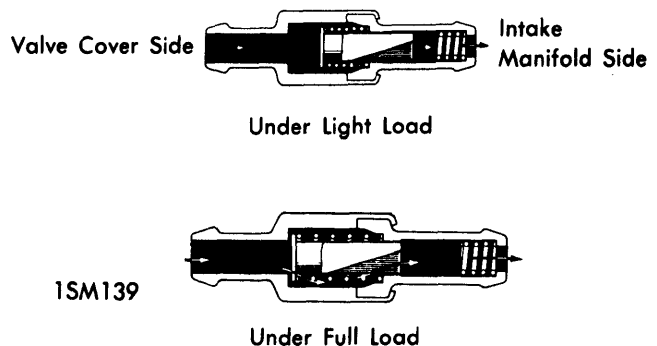

VENTILATION VALVE OPERATION

TOYOTA CLOSED (Cont.)

SERVICE PROCEDURES

After long periods of operation, ventilator valve tends to become clogged, which will affect proper engine operation. Clean air cleaner element every 3,000 miles; replace element every 18,000 miles. Clean and check PCV valve and all hoses every 12,000 miles. Replace PCV valve every 12,000 miles or 12 months (all models prior to 1972), or every 24,000 miles or 24 months (1972 and later models).

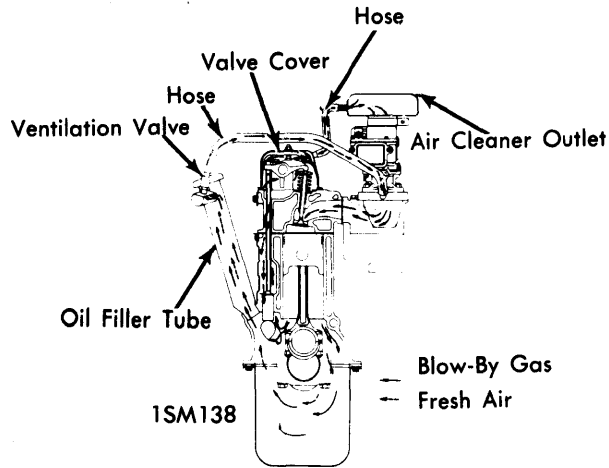

**CRANKCASE VENTILATION SYSTEM
(1.5 ENGINE)**

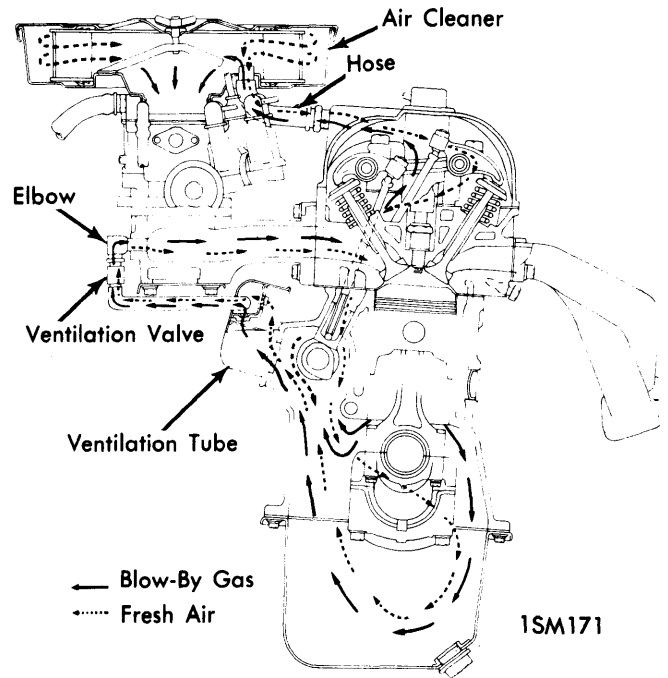

**CRANKCASE VENTILATION SYSTEM
(1.5-C ENGINE)**

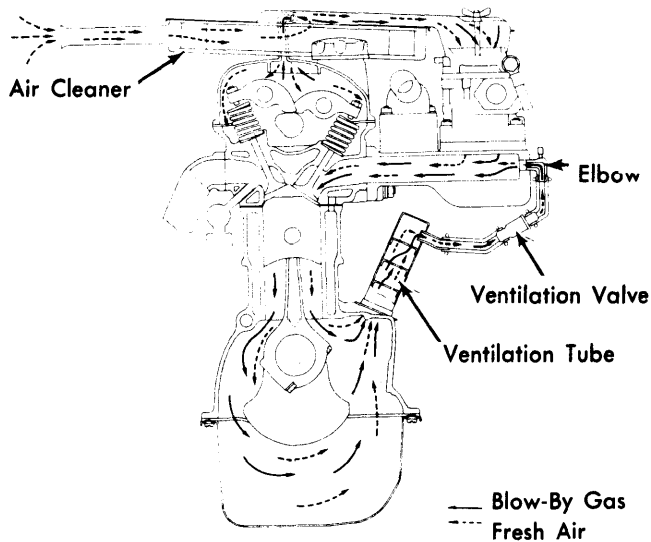

2SM002

**CRANKCASE VENTILATION SYSTEM
(2.5 ENGINE)**

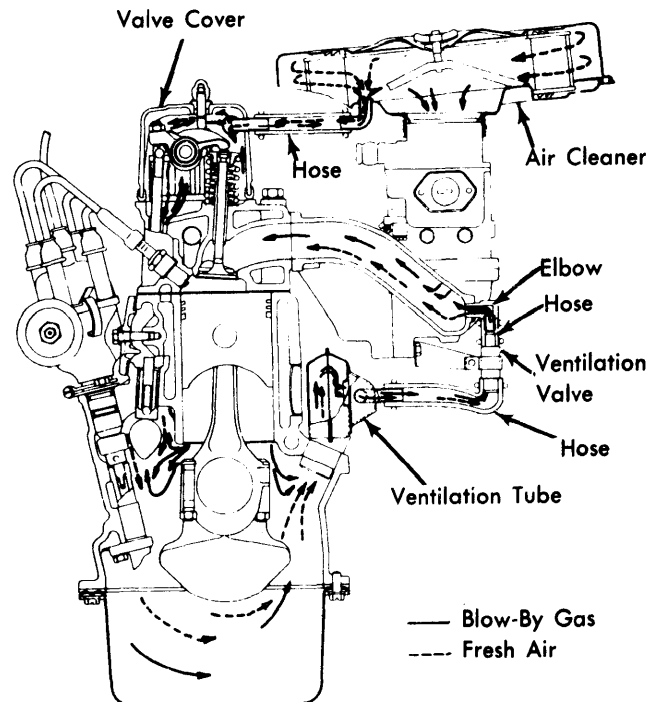

8SM298

**CRANKCASE VENTILATION SYSTEM
(3.0-C ENGINE)**