

CHRYSLER CORP. ELECTRONIC SPARK CONTROL SYSTEM (Cont.)

Carburetor Switch

Located on the end of idle stop, the carburetor switch informs the computer when the engine is at idle. When carburetor switch contacts throttle lever ground, the computer will cancel spark advance and prevent air/fuel ratio from being adjusted.

Charge Temperature Switch

This sensor is located in the No. 6 branch runner of the intake manifold. The switch will be closed whenever intake charge (air/fuel mixture) is below 60°F (16°C).

This permits no EGR timer function and no EGR valve operation. When temperature is above 60°F (16°C), the switch is open, allowing EGR timer to time out and EGR valve to operate.

OPERATION

The Spark Control Computer has 2 functional modes, "Start" and "Run". The "Start" mode operates while cranking and starting only. The "Run" mode operates after engine has started and during normal engine operation.

The two modes never operate at the same time. When cranking and starting, the pick-up coil sends a signal to the computer which is in the "Start" mode, the "Run" mode is by-passed.

During this time a fixed advance is used. Advance is determined by distributor position (basic timing). After engine starts, the pick-up coil continues to send a signal to the computer, but the computer is now in "Run" mode and "Start" mode is by-passed. The amount of timing advance is now controlled by the computer, based upon information received from the engine sensors.

The amount of spark advance is determined by 2 factors, engine speed and engine vacuum. At what point it occurs, depends upon computer programming. Advance from **vacuum** will be provided when carburetor switch is open.

The amount is programmed into the computer and is proportional to the amount of vacuum and engine RPM. Advance from **speed** will be given by the computer when the carburetor switch is open and is programmed to engine RPM.

If for some reason, there is a failure of the "Run" mode of the computer, the "Start" mode will come back into service, allowing the vehicle to be driven. Performance and economy will be greatly reduced because of the fixed timing.

TESTING

IGNITION SYSTEM STARTING TEST

1) Turn ignition switch "ON". Remove coil wire from distributor cap. Hold end of wire $\frac{1}{4}$ " from a good engine ground. Using a special jumper, intermittently jump coil negative terminal to ground. Watch for spark at coil wire. If there is a spark, it must be constant and bright blue. See Fig. 3.

2) If spark is good, continue to intermittently jumper coil negative terminal to ground, while slowly moving coil wire away from ground. Check for arcing at coil tower. If arcing occurs, replace ignition coil.

3) If spark is weak or not constant, or if there is no spark, proceed to "Failure to Start Test."

Fig. 3: Special Jumper Wire with Capacitor

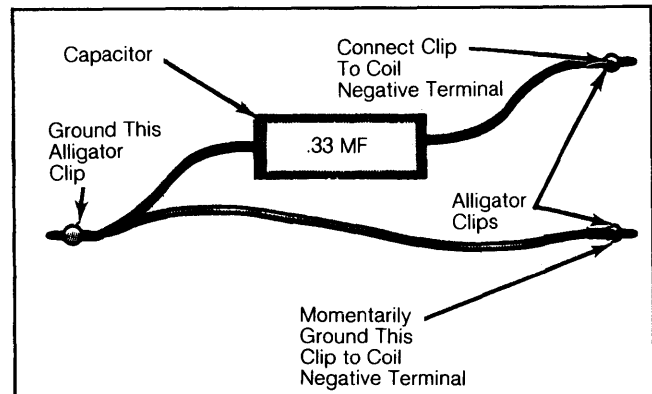

Use for "Ignition System Starting Test".

4) If spark is good and there is no arcing at coil tower, ignition system is producing necessary high secondary voltage. Make sure this spark is getting to plugs by checking distributor rotor, cap, spark plugs, and plug wires.

5) If all this checks out, but engine still will not start, the ignition system is not the problem. It will be necessary to check fuel system and engine mechanical components.

FAILURE TO START TEST

NOTE: Perform "Ignition System Starting Test" first. Failure to do so may result in lost diagnostic time or incorrect test results. If a good spark is obtained in this test, proceed to step 6).

1) Measure and record battery voltage. Measure specific gravity, which must be at least 1.220 (temperature corrected) to deliver proper voltage.

2) Turn ignition switch "OFF", and disconnect 10-wire connector from spark control computer. Repeat "Ignition System Starting Test", step 1). If spark results, replace spark control computer.

3) If no spark is obtained, check voltage at coil positive terminal. Turn ignition switch "ON". Connect positive voltmeter lead to coil positive terminal and negative lead to a good ground. Reading should be within 1 volt of battery voltage. If not, check wiring between battery and coil positive terminal.

4) If voltage at positive coil terminal was correct, connect positive voltmeter lead to coil negative terminal and negative lead to a good ground. Again, voltage should be within 1 volt of battery voltage. If not, replace ignition coil.

NOTE: You may wish to check coil primary and secondary resistance before replacing ignition coil. However, if you have battery voltage on positive side, but not on negative side, ignition coil normally requires replacement.

5) If voltage was correct at negative coil terminal, but no spark resulted in "Ignition System Starting Test", step 1), replace ignition coil.

6) If spark results, but engine will not start, turn ignition switch to the "RUN" position. Connect positive voltmeter lead to terminal 1 of 10-wire connector and negative lead to a good ground. See Fig. 4.

Distributors & Ignition Systems

CHRYSLER CORP. ELECTRONIC SPARK CONTROL SYSTEM (Cont.)

7) Reading should be within 1 volt of battery voltage. If not, check wire for open and repair it, repeating step 6) once more. Reconnect 10-wire connector to computer.

Fig. 4: Voltmeter Hookup for Checking Terminal 1 Voltage

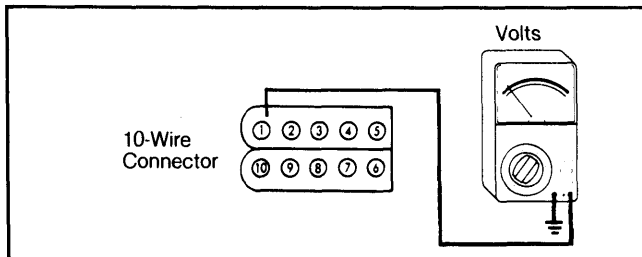

Insert positive lead into connector cavity.

8) If battery voltage was recorded in step 6), place a thin insulator (piece of paper) between curb idle adjusting screw and carburetor switch or make sure screw does not touch switch. See Fig. 5. Connect negative lead of voltmeter to a good ground.

9) Turn ignition switch to "RUN" position, and touch positive voltmeter lead to carburetor switch terminal. Reading should be approximately 5 volts. If so, proceed to step 14).

Fig. 5: Checking Voltage at Carburetor Switch

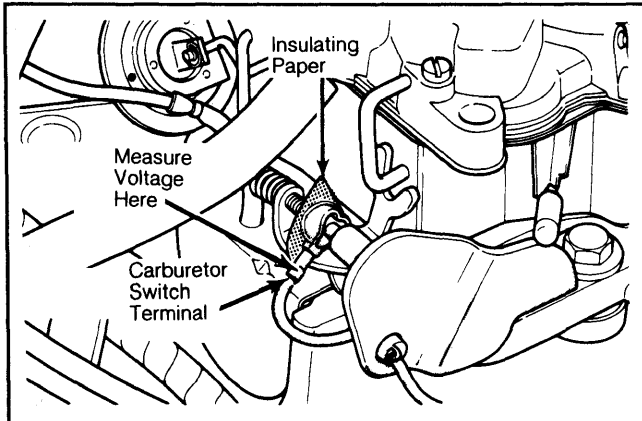

Insert insulator between contacts.

10) If voltage was not at least 5 volts, turn ignition switch "OFF". Disconnect 10-wire connector from computer. Turn ignition switch back to "RUN" position. Connect positive voltmeter lead to terminal 2 of 10-wire connector and negative lead to ground. See Fig. 6.

Fig. 6: Voltmeter Hookup for Checking Terminal 2 Voltage

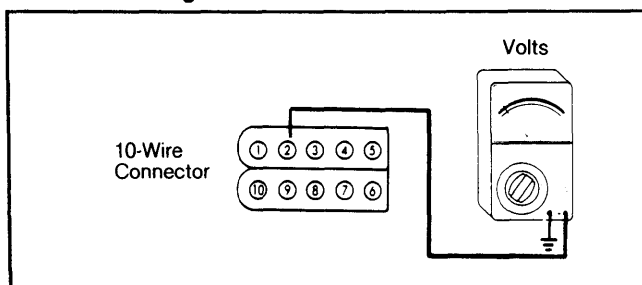

Insert positive lead into connector cavity.

11) Voltage reading should again be within 1 volt of battery voltage. If not correct, check wiring between terminal 2 and ignition switch for opens, shorts or poor connections.

12) If voltage at terminal 2 was correct, turn ignition switch "OFF". Using an ohmmeter, check continuity between terminal 7 of 10-wire connector and carburetor switch terminal. See Fig. 7. Continuity should exist. If not, check wire between connections for opens, shorts, or poor connections.

Fig. 7: Ohmmeter Hookup for Checking Carburetor Switch Wiring Harness

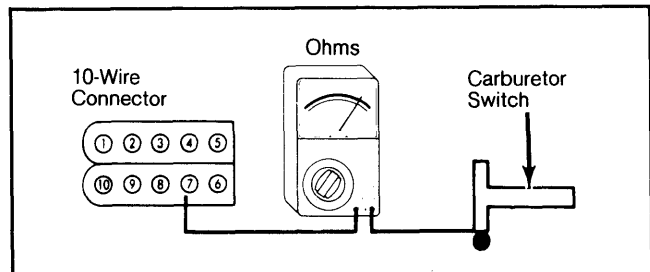

Insert ohmmeter lead into connector cavity.

13) If continuity is present, use an ohmmeter with leads attached to terminal 10 and engine ground to check continuity of ground circuit. See Fig. 8. If there is continuity, replace computer. If there is no continuity, check wire from terminal 10 to ground. If engine fails to start, proceed to next step.

Fig. 8: Ohmmeter Hookup for Checking Computer Ground Circuit

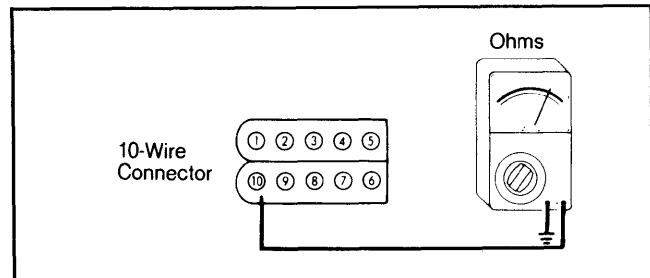

Insert ohmmeter lead into connector cavity.

14) Turn ignition switch "OFF". Attach ohmmeter leads to terminals 5 and 9 of 10-wire harness connector to check run pick-up coil resistance and to terminals 3 and 9 to check start pick-up coil resistance. See Fig. 9. Resistance should be 150-900 ohms. If so, proceed to step 16).

15) If not, disconnect distributor connectors, and attach ohmmeter leads to run pick-up coil leads and then to start pick-up coil leads coming from distributor. If resistance is now okay, wiring harness is defective. If resistance is still not 150-900 ohms, replace pick-up coils, as necessary.

16) Next, connect one lead of an ohmmeter to engine ground and touch other lead to each terminal of 2 leads coming from each of the 2 distributor pick-up coils. There should be no continuity. If continuity is indicated replace pick-up coils as necessary.

17) Remove distributor cap and check each reluctor-to-pick-up coil air gap. When setting start pick-up coil gap, use a .006" non-magnetic feeler gauge. Check

CHRYSLER CORP. ELECTRONIC SPARK CONTROL SYSTEM (Cont.)

Fig. 9: Ohmmeter Hookup for Checking Pick-Up Coil Resistance

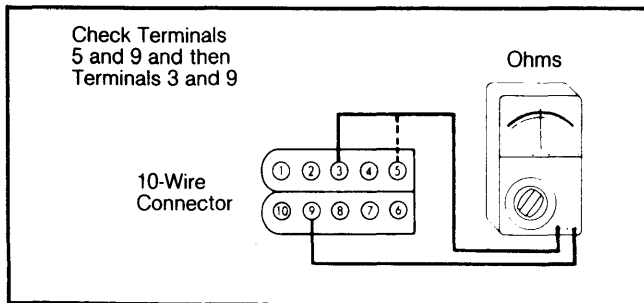

Resistance should be 150-900 ohms for each pick-up coil.

gap using an .008" gauge. When setting run pick-up gap, set with .012" gauge and check with .014" gauge. Larger gauges should not fit in gap. See Fig. 10.

Fig. 10: Checking Distributor Pick-Up Air Gap

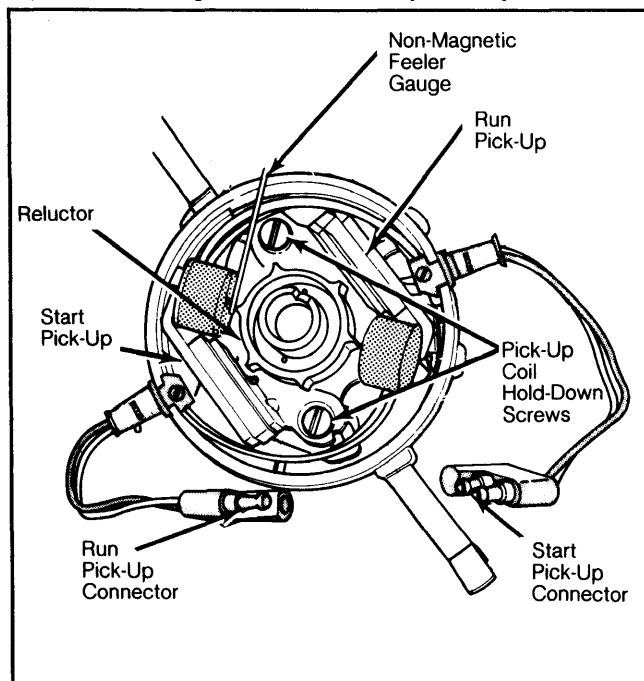

Use non-magnetic feeler gauge.

NOTE: To adjust gap, loosen pick-up coil hold-down screws, move pick-up coil against feeler gauge resting against reluctor tooth. Tighten hold-down screw, remove feeler gauge, and recheck gap.

18) Install distributor cap, and reinstall all wiring. If engine fails to start, replace spark control computer. If it still fails to start, install original computer and retest.

IGNITION COIL RESISTANCE CHECKS

1) If ignition coil is suspected, connect ohmmeter leads to positive and negative primary terminals. Ignition switch should be "OFF" and primary coil wires removed. Primary resistance should read 1.60-1.79 ohms for Prestolite coils; 1.34 to 1.55 ohms for Essex coils.

2) Then move ohmmeter leads to coil negative terminal and coil tower. Ohmmeter resistance reading should be 9,400-11,700 for Prestolite coils, 9,000-12,200 ohms for Essex coils.

3) Replace ignition coil if either specification is not obtained.

POOR PERFORMANCE TEST

Basic Advance Timing Test

1) Connect an adjustable timing light to engine so that total timing advance at crankshaft can be checked. Connect a jumper wire between carburetor switch and a good ground.

2) Be sure vacuum line is connected to vacuum transducer on computer. Observe timing mark on crankshaft damper immediately after engine starts to run. Adjust timing light so basic timing signal is seen at timing plate.

3) The meter on timing light should then show amount of advance, as indicated on vehicle emission control label.

Spark Advance of Computer

1) Set basic timing. Start engine and allow it to warm to normal operating temperature. Put transmission in neutral and set parking brake.

NOTE: The Spark Control Computer has various spark advance schedules incorporated into its microprocessor for operation at differing engine temperatures. Therefore, be sure engine is at normal operating temperature before testing.

2) Place a thin insulator (piece of paper) between curb idle adjusting screw and carburetor switch, or make sure screw is not touching switch. See Fig. 5. Remove and plug vacuum line at vacuum transducer.

CAUTION: Use a metal exhaust tube for step 3), as high temperatures could cause rubber hose to catch fire.

3) Connect an auxiliary vacuum supply to vacuum transducer, and set for 16 in. Hg vacuum. Increase engine speed to 2000 RPM, wait 1 minute for specified accumulator clock up time, and then check specifications. Advance specifications are in addition to basic advance.

4) If computer fails to obtain specified settings, replace computer.

CARBURETOR SWITCH TEST

1) Grounding the carburetor switch eliminates all spark advance on most systems. Turn key off, and disconnect 10-wire harness connector from computer.

2) With throttle completely closed, check continuity between terminal 7 and a good ground. If no continuity is indicated, check wire and carburetor switch. Recheck basic timing.

3) With throttle opened, check continuity between terminal 7 and a good ground. There should be no continuity.

CHARGE TEMPERATURE & COOLANT SWITCH

1) Turn ignition switch "OFF", and disconnect wire from charge temperature switch. Connect one lead of

Distributors & Ignition Systems

CHRYSLER CORP. ELECTRONIC SPARK CONTROL SYSTEM (Cont.)

ohmmeter to a good engine ground (or to switch's ground terminal). Connect other lead to center terminal of coolant switch. Check for continuity.

2) For a cold engine, continuity should be present (resistance less than 100 ohms). If not, replace the switch. The charge temperature switch must be cooler than 60°F to obtain this reading.

3) For an engine at normal operating temperature, the terminal should show no continuity. If it does, replace coolant switch.

ELECTRONIC THROTTLE CONTROL SYSTEM TEST

The Spark Control Computer also incorporates an electronic throttle system on Federal 6-cylinder models. A solenoid, mounted on the carburetor, is energized when the A/C, heater, electronic backlite, or electronic timers are activated.

The 2 timers, incorporated in the ignition system, operate when throttle is closed, plus a time delay of 2 seconds, or after an engine start condition (EGR time delay).

1) To test system, connect a tachometer to engine. Start engine. Depress accelerator and let it up. A higher than curb idle speed should be seen for the length of EGR schedule.

2) If vehicle is equipped with A/C or electronic backlite, turn system on and depress accelerator for a brief period. A higher than curb idle speed should result. Turn system off and normal idle speed should return.

NOTE: A/C clutch will cycle as it is running. This should not be mistaken as part of electronic control.

3) If speed increases do not occur, disconnect 3-way connector at carburetor. Check solenoid with

ohmmeter, measuring resistance from terminal that contained Black wire to ground. Resistance should read 15-35 ohms. If not, replace solenoid.

4) Start vehicle and before delay has timed out, measure voltage of Black wire at 3-way connector. Charging voltage should be observed. If not, replace computer or Gray start timer.

5) After time delay, turn A/C or backlite on. Charging voltage should be read. If not, check wiring back to instrument panel for an open circuit.

OVERHAUL

Disassembly

1) Remove distributor cap. Using 2 screwdrivers, pry off rotor from shaft. Remove reluctor by prying up from bottom of reluctor using 2 pry bars or screwdrivers with a maximum width of $\frac{7}{16}$ ". Be careful not to distort or damage reluctor teeth.

2) Remove 2 screws and lock washers attaching lower plate to housing, and lift out lower plate and pick-up coils as an assembly. Do not attempt to remove distributor cap clamps, as they are peened in place.

3) If distributor has excessive shaft side play (more than .006"), replace housing shaft and reluctor sleeve by removing shaft, retaining pin and sliding drive gear off end of shaft.

NOTE: Prior to removing shaft, scribe a line on end of shaft from center of shaft to edge. Line should align with space between 2 gear teeth.

4) Use a file to clean burrs from around pin hole in shaft, and remove lower thrust washer. Push shaft up, and remove shaft through top of distributor housing.

Reassembly

To assemble, reverse disassembly procedure

Fig. 11: Distributor for 6-Cylinder Vehicles

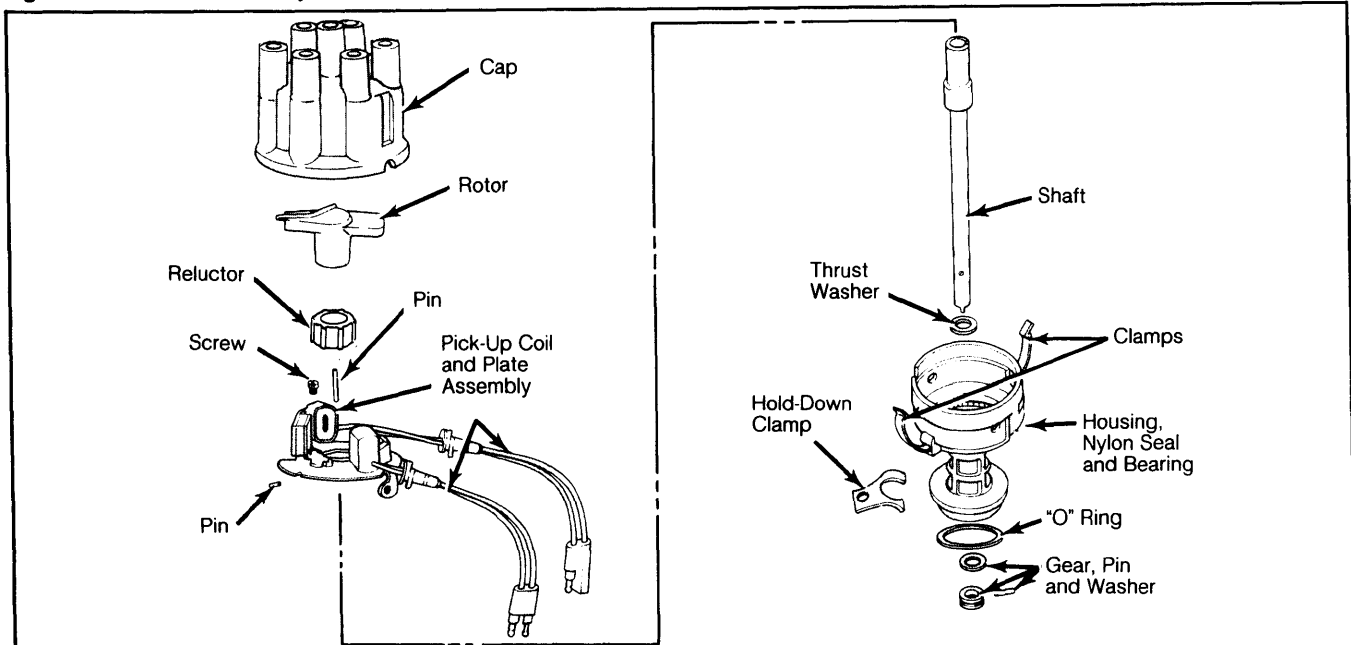

Notice difference between start and run pick-up coil connectors.