

1982 Exhaust Emission Systems

GENERAL MOTORS VACUUM DIAGRAMS

MODEL IDENTIFICATION

Truck models, listed in tables, are identified using manufacturers letter and number designations. The letters identify the vehicle model series (i.e., "C" is conventional chassis, including Pickup, Blazer and Suburban). The number reference identifies the vehicles load capacity. Refer to following charts for actual letter and number designations.

VEHICLE SERIES IDENTIFICATION

Vehicle Series	I.D. Letter
Conventional Chassis (2-WD)	C
Conventional Chassis (2-WD)	S
Conventional Chassis (4-WD)	K
Conventional Van Chassis	G
Forward Control/Stepvan Chassis	P

VEHICLE LOAD CAPACITY

Chevrolet Number	GMC Number	Ton Capacity
10	15	1/2
10	1500	1/2
20	2500	3/4
30	3500	1

GENERAL MOTORS VACUUM DIAGRAM REFERENCE CHART

Vehicle Model, Series & Engine	Application	Transmission	Equipment	Fig. No.
Light Duty 1.9L 4-Cyl. S10	Calif.	Auto.	AIR	1
	Calif.	Man.	AIR	2
	Hi. Alt.	Auto.	AIR	3
	Fed. & Hi. Alt.	Man.	AIR	4
	Fed.	Auto.	AIR	5
Light Duty 2.8L V6 S10	Fed. & Hi. Alt.	Auto. & Man.	AIR	6
	Fed.	Auto.	AIR	7
	Calif.	Man.	AIR	8
	Calif.	Auto.	AIR	9
Light Duty 4.1L 6-Cyl. C10 & K10	Fed. & Hi. Alt.	Auto.		10
	Fed. & Hi. Alt.	Auto.		11
	Fed. & Hi. Alt.	Auto.		18
	Fed. & Hi. Alt.	Auto.		19
	Fed.	Man.		20
	Fed.	Man.		21
	Fed.	Auto.		22
	Fed.	Auto.		23
Light Duty 4.1L 6-Cyl. G10 & G20	Calif.	Man.		12
	Calif.	Man.		13
	Calif.	Auto.		16
	Calif.	Auto.		17
	Fed. & Hi. Alt.	Man.	AIR	29
	Fed. & Hi. Alt.	Auto.	AIR	30
	Hi. Alt.	Auto.	AIR	32
	Fed.	Man.		33
	Fed.	Auto.	Exc. AIR	34
	Light Duty 4.1L 6-Cyl. G30	Fed & Hi. Alt.	Auto.	
Fed.		Man.		14
Fed.		Man.		15
Heavy Duty 4.8L 6-Cyl. P20 & P30	Fed.		AIR	24

1982 Exhaust Emission Systems

3-91

GENERAL MOTORS VACUUM DIAGRAMS (Cont.)

GENERAL MOTORS VACUUM DIAGRAM REFERENCE CHART

Vehicle Model, Series & Engine	Application	Transmission	Equipment	Fig. No.
Light Duty 5.0L V8 C10	Hi. Alt.	Man.	AIR	26
		Auto.	AIR	27
	Fed. & Hi. Alt.	Man.	AIR	29
	Fed. & Hi. Alt.	Auto.	AIR	30
	Hi. Alt.	Auto.	AIR	32
	Fed. Fed.	Man.	Exc. AIR	33 34
Light Duty 5.0L V8 C20	Fed. & Hi. Alt	Man.	AIR	29
Light Duty 5.0L V8 G10 & G20	Fed. & Hi. Alt. Hi. Alt.	Man.	AIR	25
		Auto.	AIR	28
		Auto.	AIR	31
Light Duty 5.0L V8 K10	Fed. & Hi. Alt. Fed. & Hi. Alt.	Man.	AIR	29
		Man.	AIR	30
Light Duty 5.7L V8 C10 & C20 K10 & K20	Calif.	Auto.	AIR	43
	Fed. & Hi. Alt.	Man.	AIR	36
	Fed. & Hi. Alt.	Auto.	AIR	39
	Calif.	Auto.	AIR	43
	Fed. & Hi. Alt.	Man.	AIR	38
	Fed. & Hi. Alt.	Auto.	AIR	40
Medium Duty 5.7L V8 G20 & G30	Calif.	Auto.	AIR	42
Heavy Duty 5.7L V8 C20 & K20 G30, P20 & P30	Calif. Fed. Fed.	Auto.	AIR	35
		Auto.	AIR	37
		Auto.	AIR	41
Light Duty 6.2L V8 C10, C20, K10 & K20	Calif., Fed. & Hi. Alt.	Auto. & Man.		45
Medium Duty 6.2L V8 C10, C20, K10 & K20	Calif., Fed. & Hi. Alt.	Auto. & Man.		46
Heavy Duty 7.4L V8 C20, C30, K20 & K30	Fed. Calif.		AIR	47
			AIR	48

EMISSION CONTROL DEVICE ABBREVIATIONS

AIR — Air Injection Reactor
DVTR — Diverter Valve
EFE — Early Fuel Evaporation
EGR — Exhaust Gas Recirculation
PCV — Positive Crankcase Ventilation
TRC — Throttle Return Control
TVS — Thermal Vacuum Switch

1982 Exhaust Emission Systems

GENERAL MOTORS VACUUM DIAGRAMS

Fig. 1: 1.9L 4-Cyl. California Automatic Trans. S10 & S15

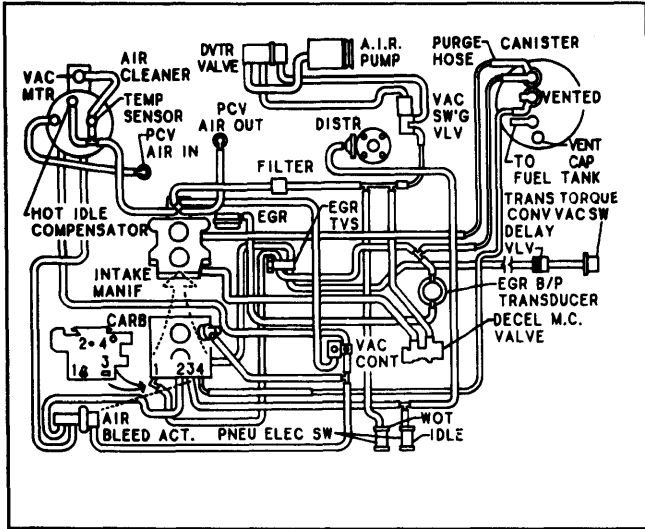

Fig. 4: 1.9L 4-Cyl. Federal & High Altitude Manual Trans. S10 & S15

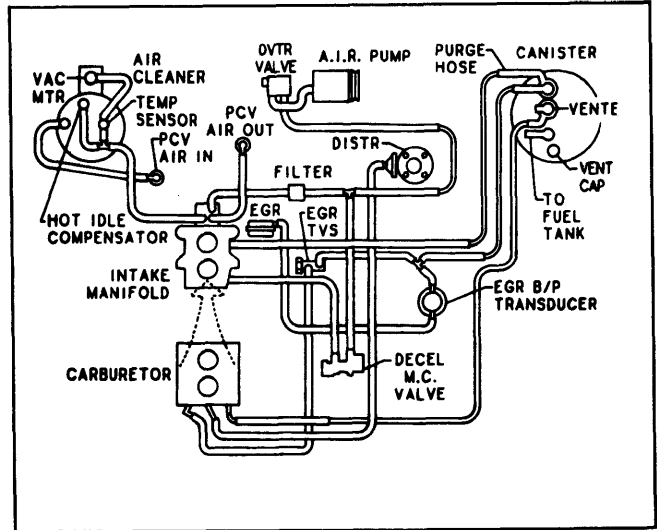

Fig. 2: 1.9L 4-Cyl. California Manual Trans. S10 & S15

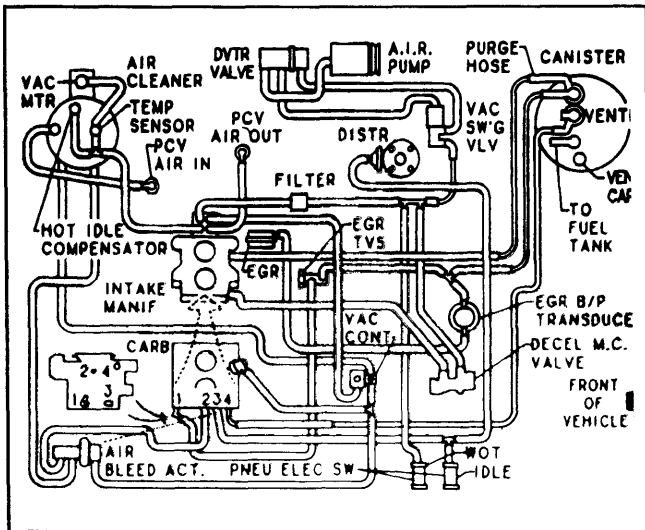

Fig. 5: 1.9L 4-Cyl. Federal Automatic Trans. S10 & S15

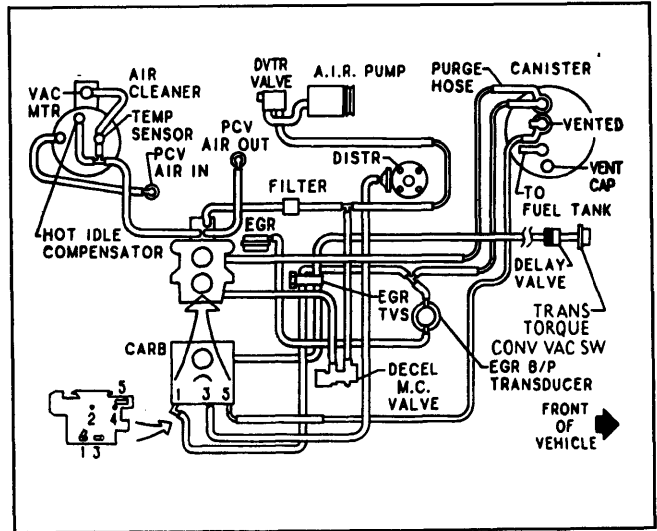

Fig. 3: 1.9L 4-Cyl. High Altitude Automatic Trans. S10 & S15

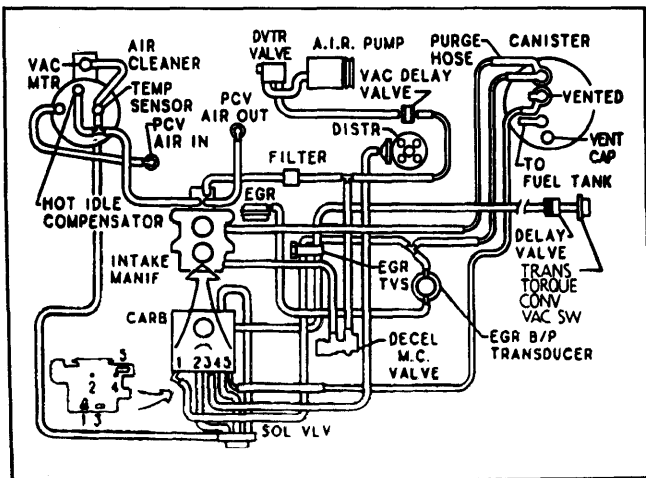
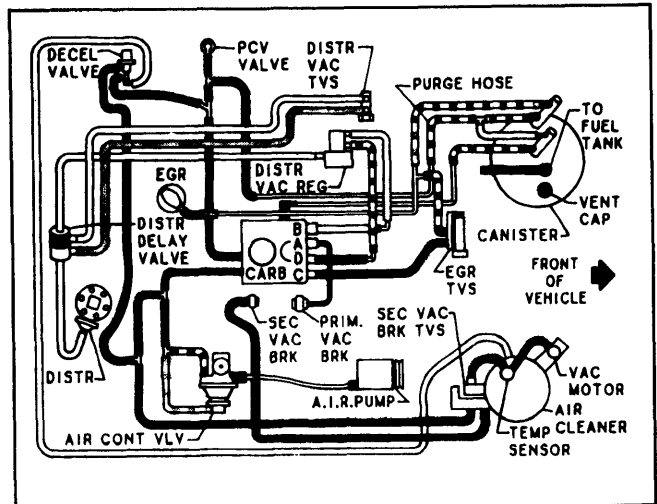

Fig. 6: 2.8L 6-Cyl. Federal & High Altitude Automatic & Manual Trans. S10 & S15



GENERAL MOTORS VACUUM DIAGRAMS (Cont.)

Fig. 7: 2.8L 6-Cyl. Federal Automatic Trans. S10 & S15

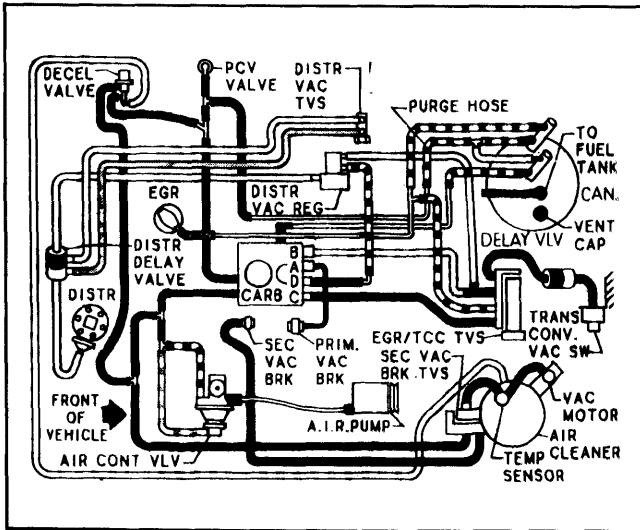

Fig. 10: 4.1L 6-Cyl. Federal & High Altitude Automatic Trans. C10 & K10 Models

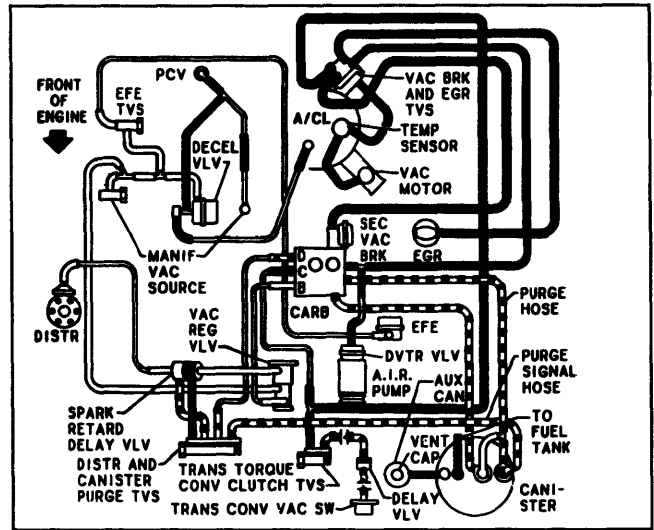

Fig. 8: 2.8L 6-Cyl. California Manual Trans. S10 & S15

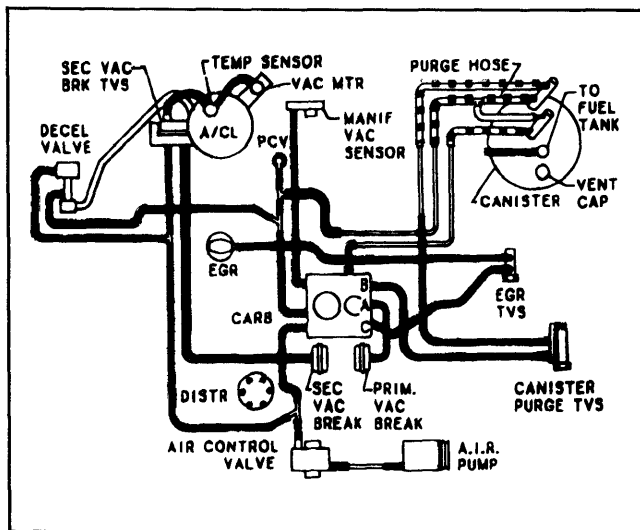

Fig. 11: 4.1L 6-Cyl. Federal & High Altitude Automatic Trans. G30 & K10 Models

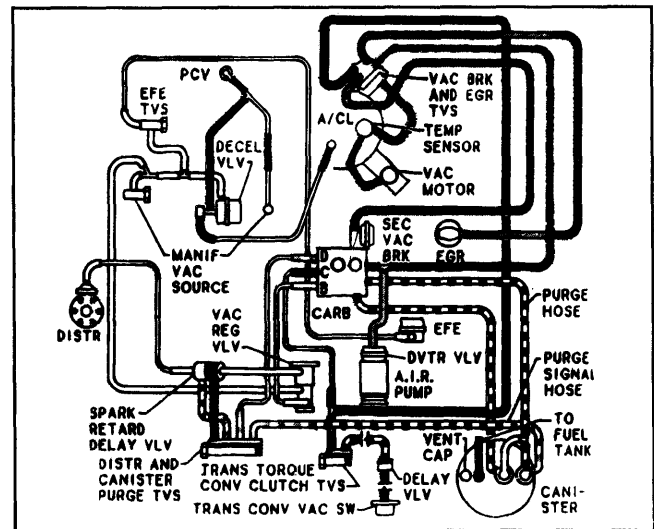

Fig. 9: 2.8L 6-Cyl. California Automatic Trans. S10 & S15

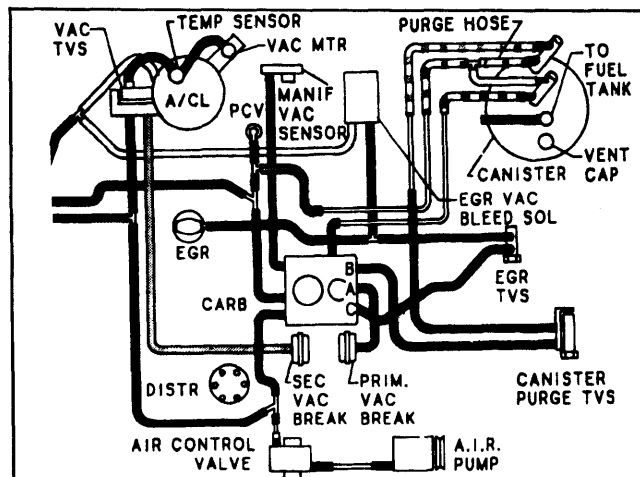
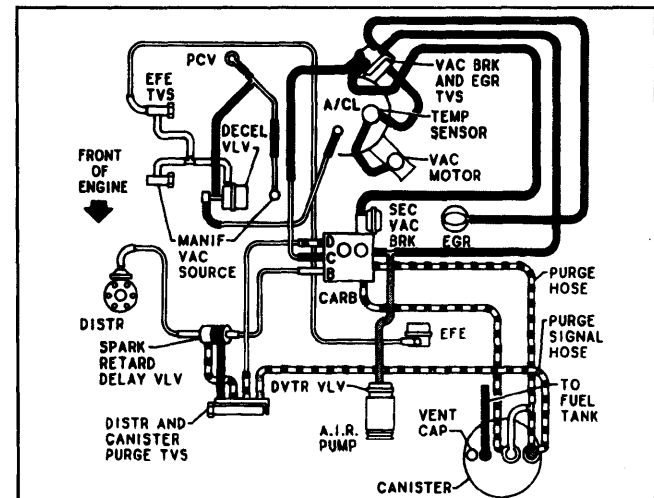

Fig. 12: 4.1L 6-Cyl. California Manual Trans. G10 & G20 Models



1982 Exhaust Emission Systems

GENERAL MOTORS VACUUM DIAGRAMS

Fig. 13: 4.1L 6-Cyl. California Manual Trans. G10 & G20 Models With Aux. Canister

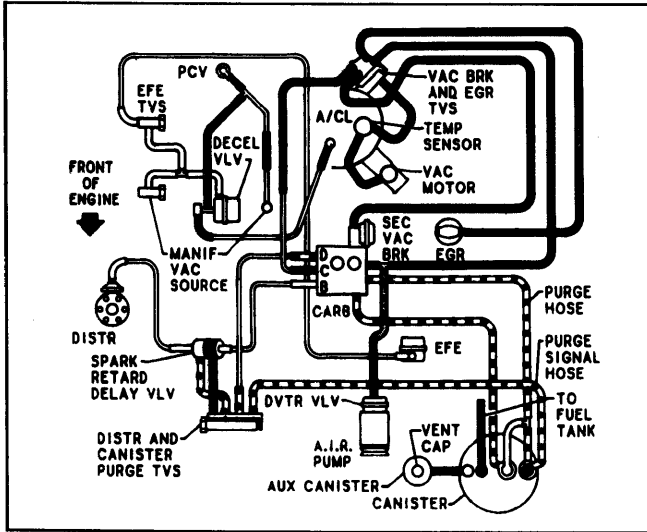

Fig. 16: 4.1L 6-Cyl. California Automatic Trans. G10 & G20 Models

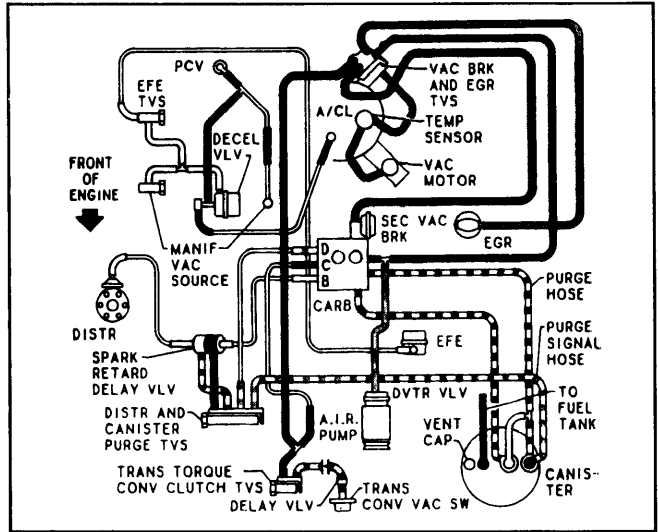

Fig. 14: 4.1L 6-Cyl. Federal Manual Trans. G30 Models With Aux. Canister

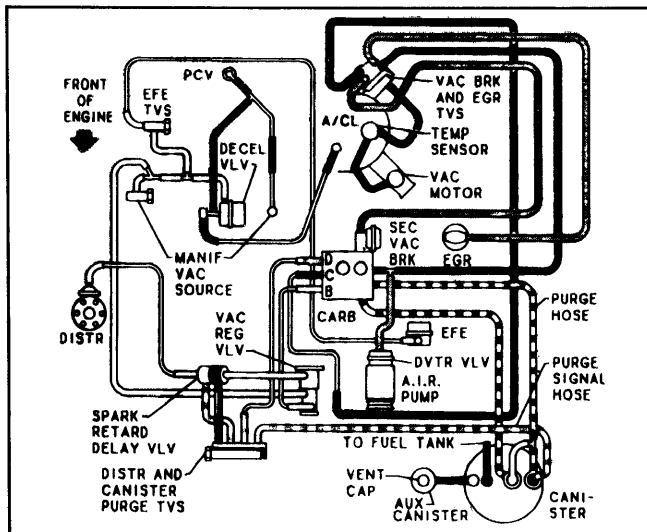

Fig. 17: 4.1L 6-Cyl. California Automatic Trans. G10 & G20 Models

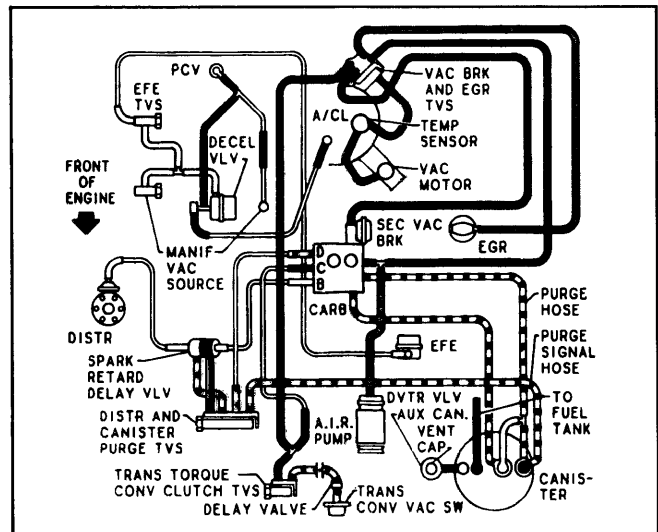

Fig. 15: 4.1L 6-Cyl. Federal Manual Trans. G30 Models

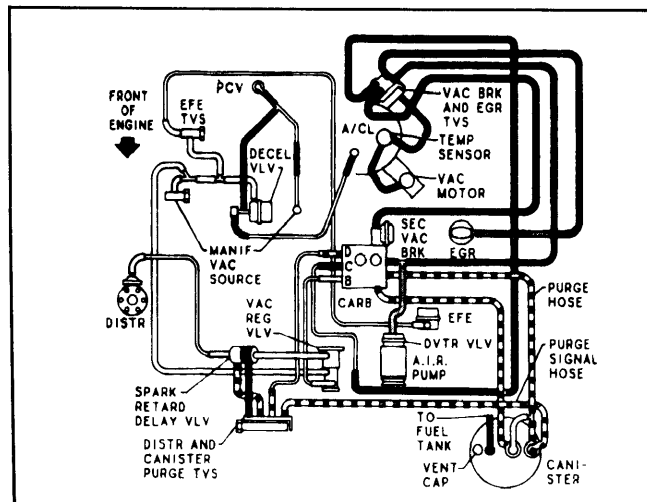
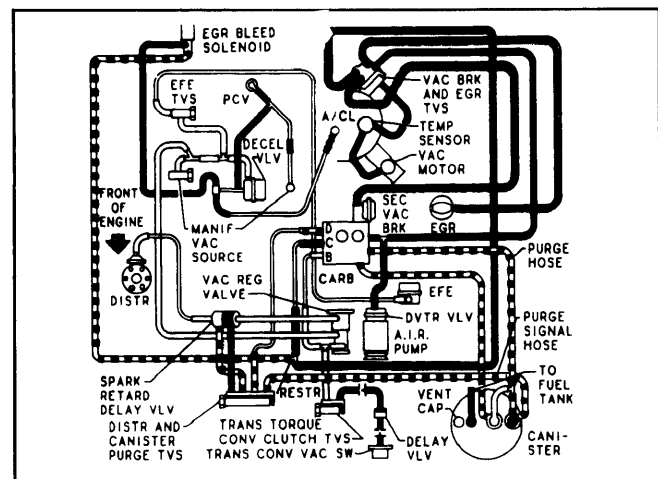

Fig. 18: 4.1L 6-Cyl. Federal & High Altitude Automatic Trans. C10 Models



1982 Exhaust Emission Systems

GENERAL MOTORS VACUUM DIAGRAMS (Cont.)

Fig. 19: 4.1L 6-Cyl. Federal & High Altitude Automatic Trans. C10 Models

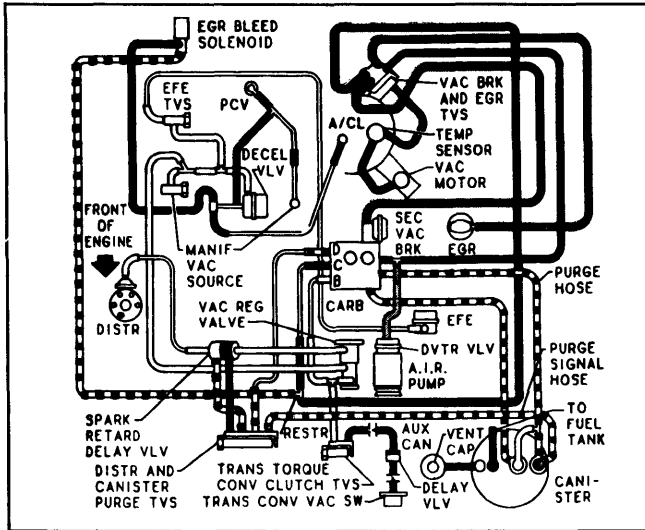

Fig. 20: 4.1L 6-Cyl. Federal Manual Trans. C10, G10 & G20 Models

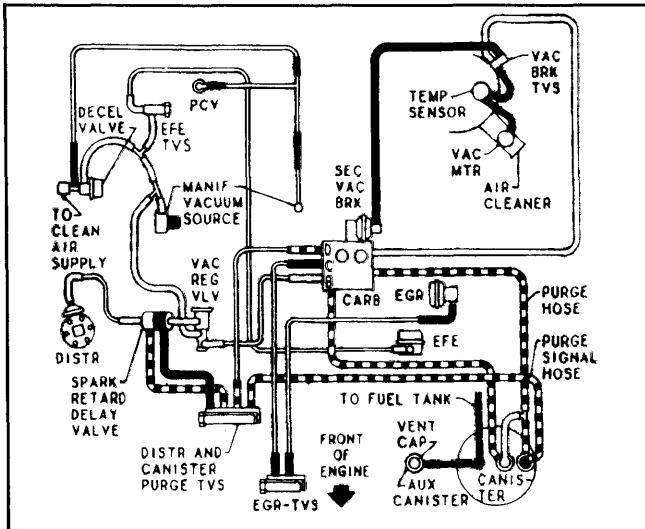

Fig. 21: 4.1L 6-Cyl. Federal Manual Trans. C10 & K10 Models

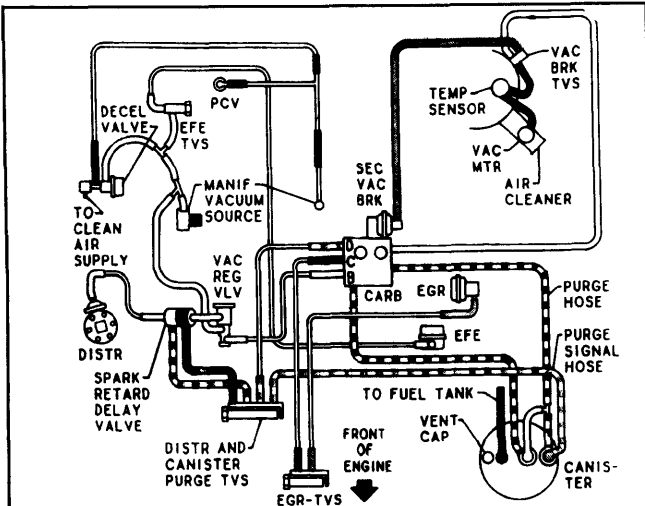

Fig. 22: 4.1L 6-Cyl. Federal Automatic Trans. C10, G10 & G20 Models

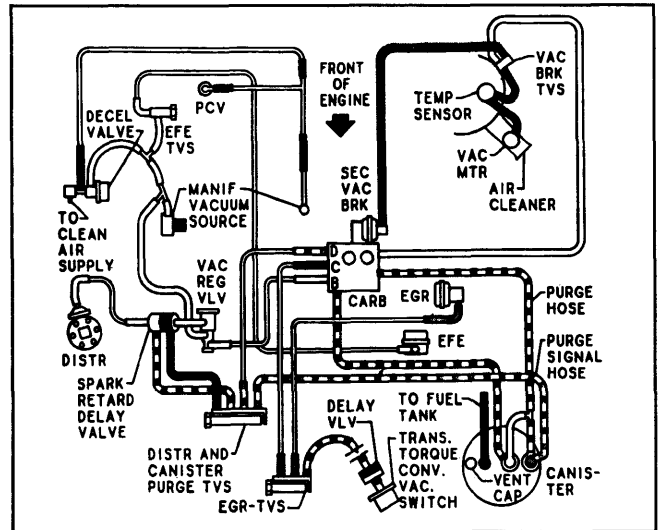

Fig. 23: 4.1L 6-Cyl. Federal Automatic Trans. C10, G10 & G20 Models

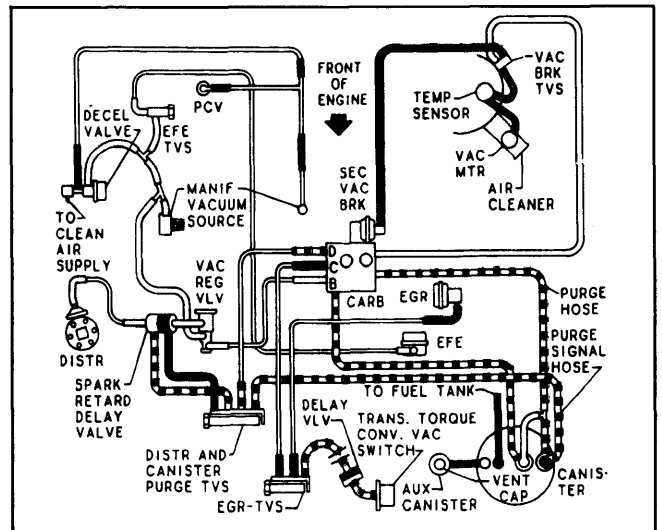
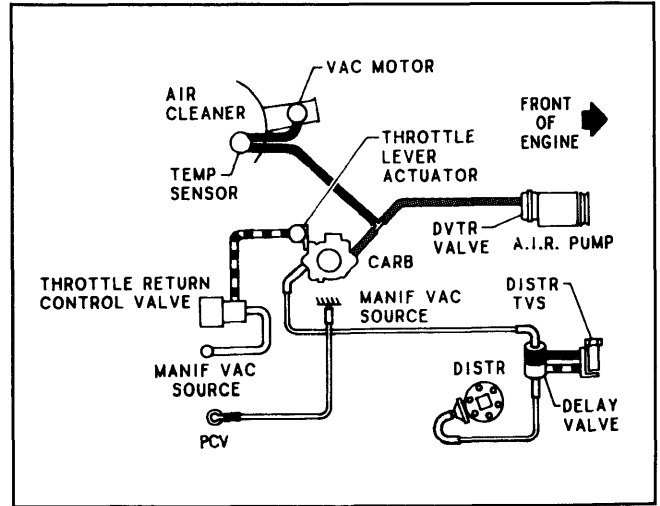

Fig. 24: 4.8L 6-Cyl. Federal P20 & P30 Models



1982 Exhaust Emission Systems

GENERAL MOTORS VACUUM DIAGRAMS (Cont.)

Fig. 25: 5.0L V8 Federal & High Altitude Manual Trans. G10 & G20 Models

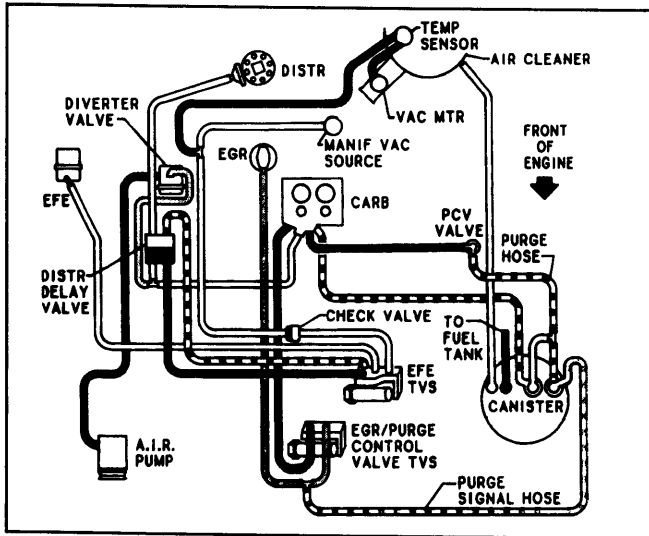

Fig. 28: 5.0L V8 High Altitude Automatic Trans. G10 & G20 Models

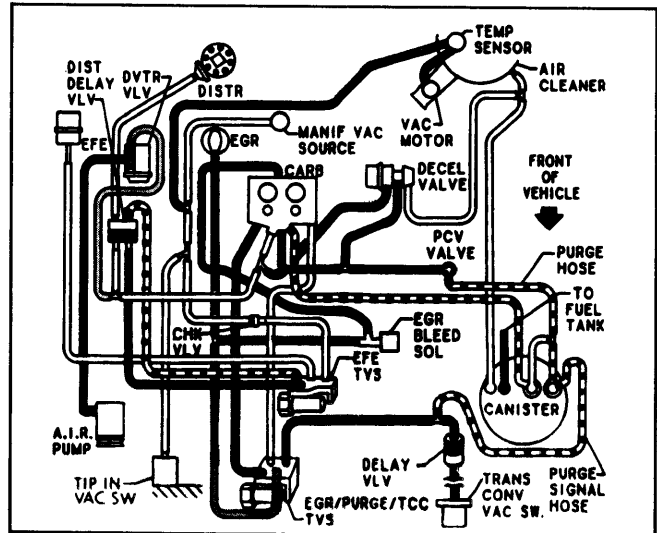

Fig. 26: 5.0L V8 High Altitude Manual Trans. C10 Models

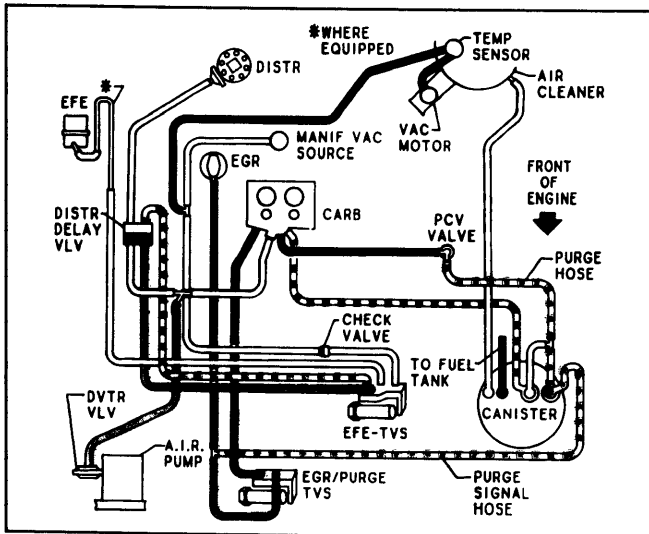

Fig. 29: 5.0L V8 Federal & High Altitude Manual Trans. C10, C20 & K10 Models

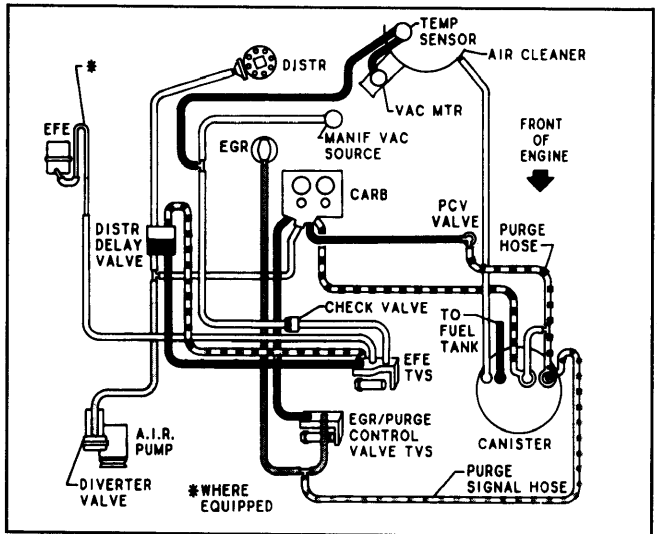

Fig. 27: 5.0L V8 Automatic Trans. C10 Models

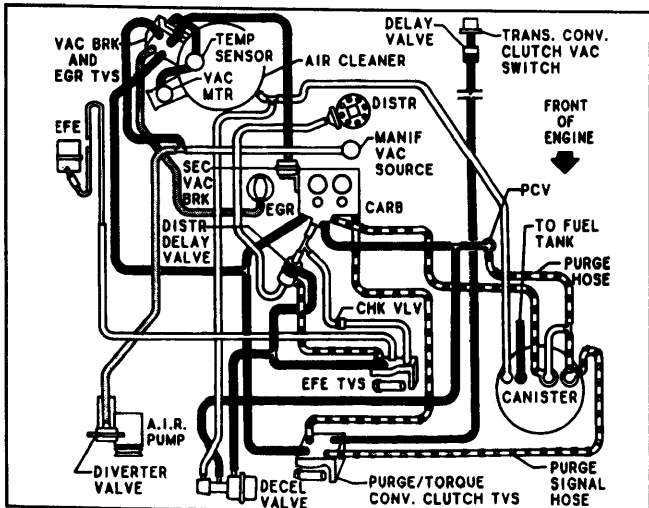
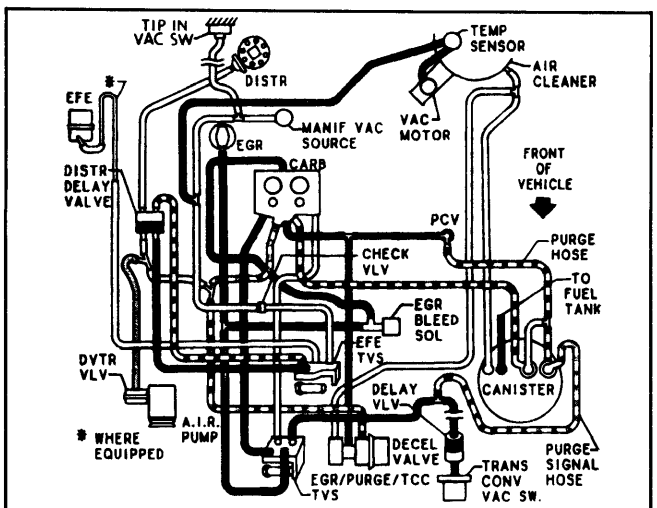

Fig. 30: 5.0L V8 Federal & High Altitude Automatic Trans. C10 & K10 Models



GENERAL MOTORS VACUUM DIAGRAMS (Cont.)

Fig. 31: 5.0L V8 Automatic Trans. G10 & G20 Models

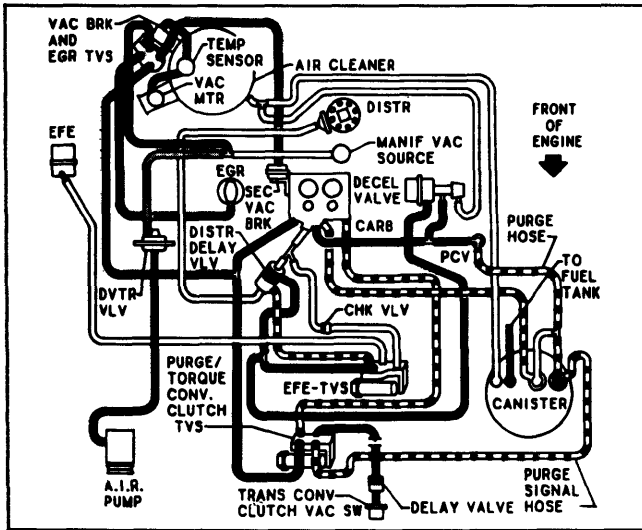

Fig. 34: 5.0L V8 Federal Automatic Trans. C10 Models (Exc. With Air Injection System)

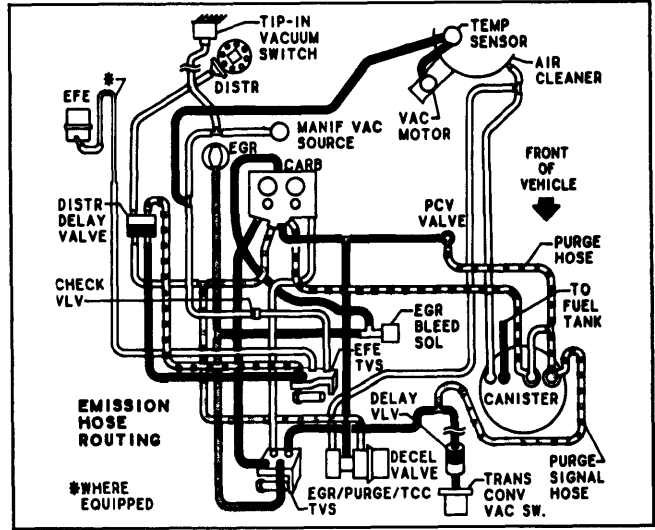

Fig. 32: 5.0L V8 High Altitude Automatic Trans. C10 Models

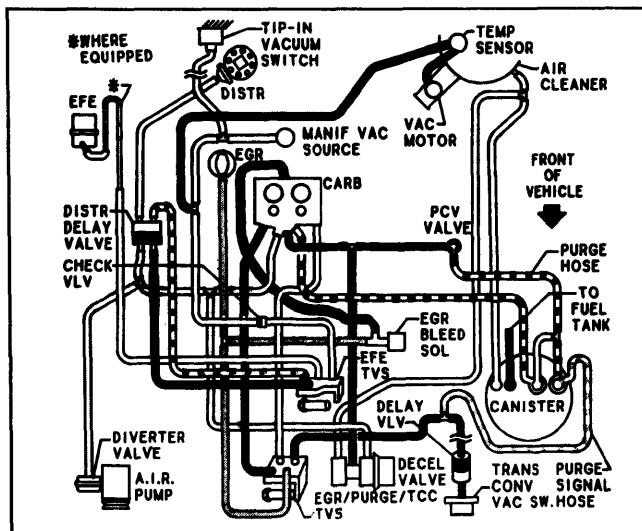

Fig. 35: 5.7L V8 California Automatic Trans.

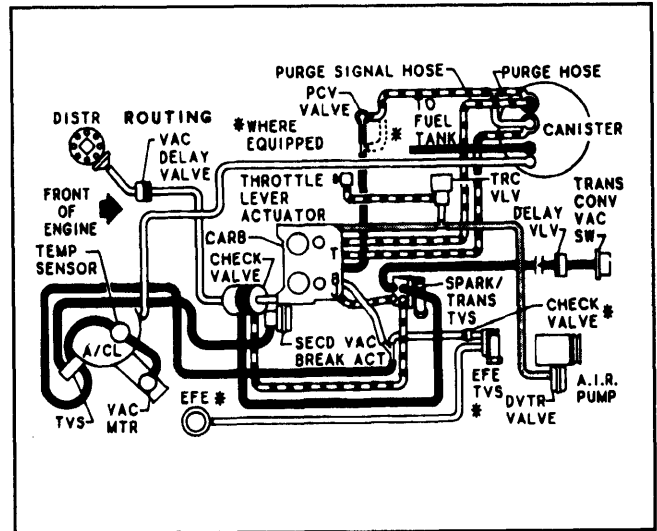

Fig. 33: 5.0L V8 Federal Manual Trans. C10 Models

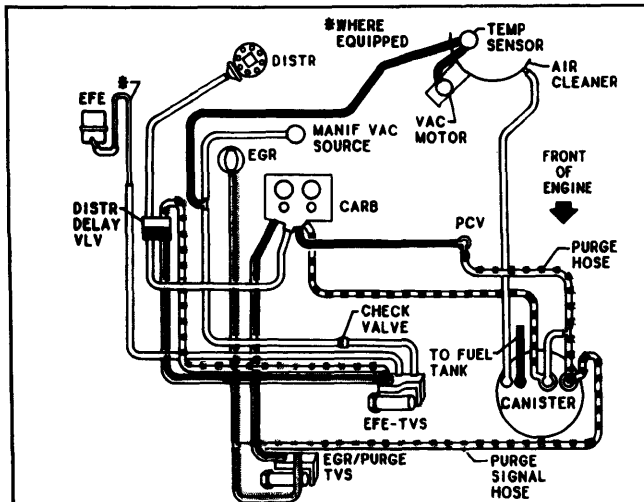
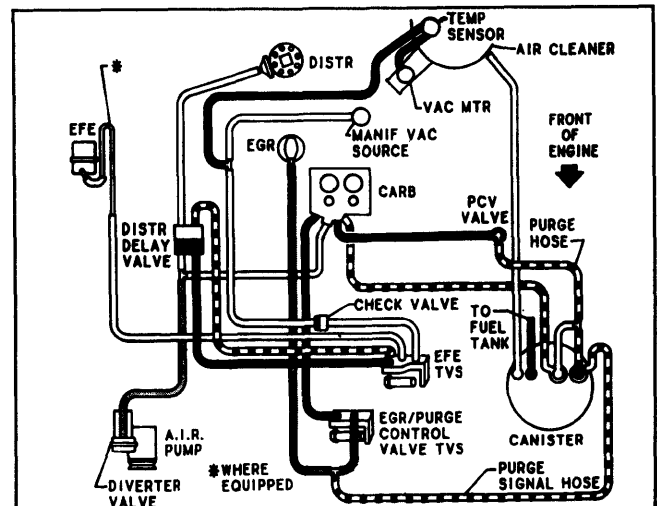

Fig. 36: 5.7L V8 Federal & High Altitude Manual Trans. K10 & K20 Models



1982 Exhaust Emission Systems

GENERAL MOTORS VACUUM DIAGRAMS (Cont.)

Fig. 37: 5.7L V8 Federal Automatic Trans. C20 & K20 Models

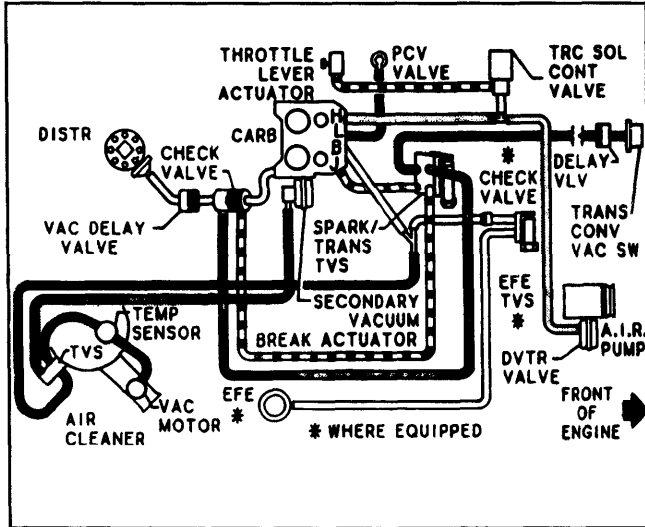

Fig. 38: 5.7L V8 Federal & High Altitude Manual Trans. G10 Models

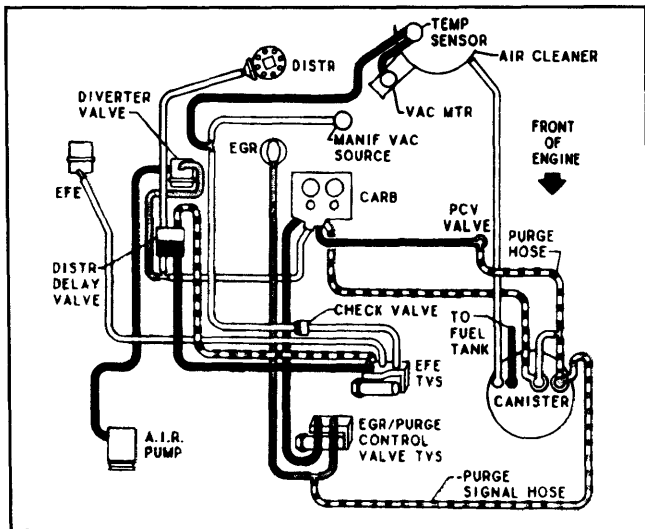

Fig. 39: 5.7L V8 Federal & High Altitude Automatic Trans. K20 Models

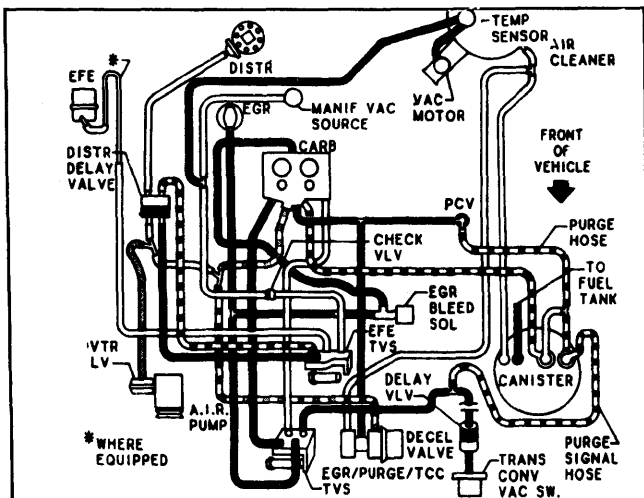

Fig. 40: 5.7L V8 Federal & High Altitude Automatic Trans. G10 & G20 Models

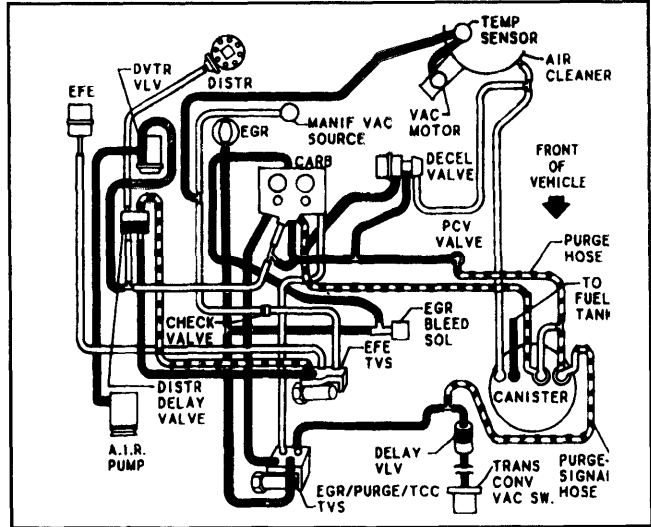

Fig. 41: 5.7L V8 Federal G30, P20 & P30 Models

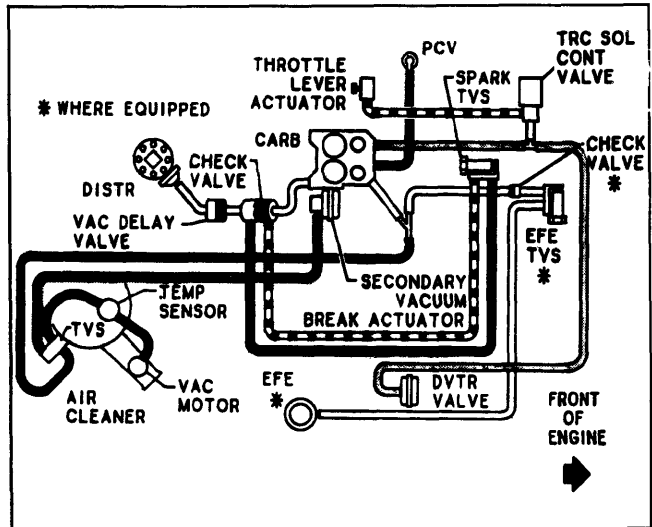
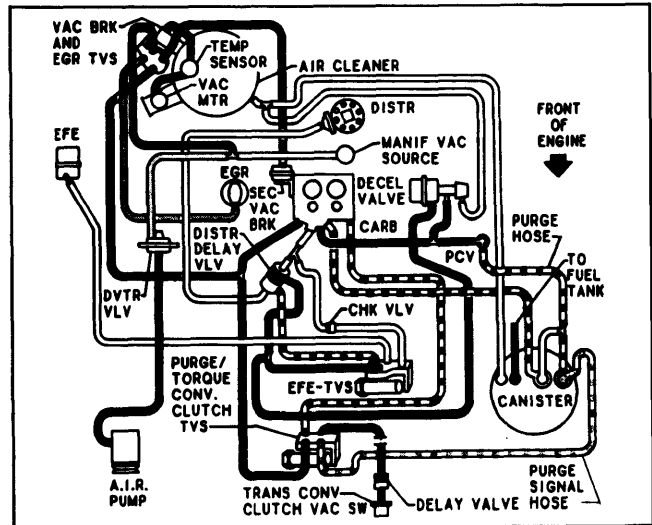

Fig. 42: 5.7L V8 California Automatic Trans. G20 & G30 Models



1982 Exhaust Emission Systems

3-99

GENERAL MOTORS VACUUM DIAGRAMS (Cont.)

Fig. 43: 5.7L V8 California Automatic Trans. C10, C20 & K10 Models

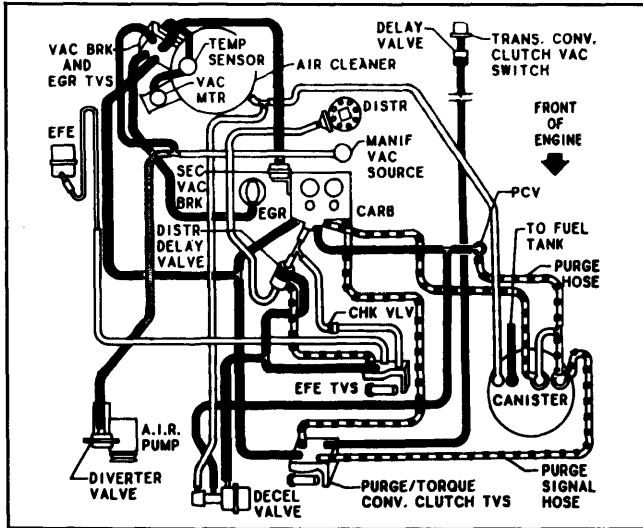

Fig. 46: 6.2L V8 California, Federal & High Altitude Automatic & Manual Trans. C10, C20, K10 & K20 Models

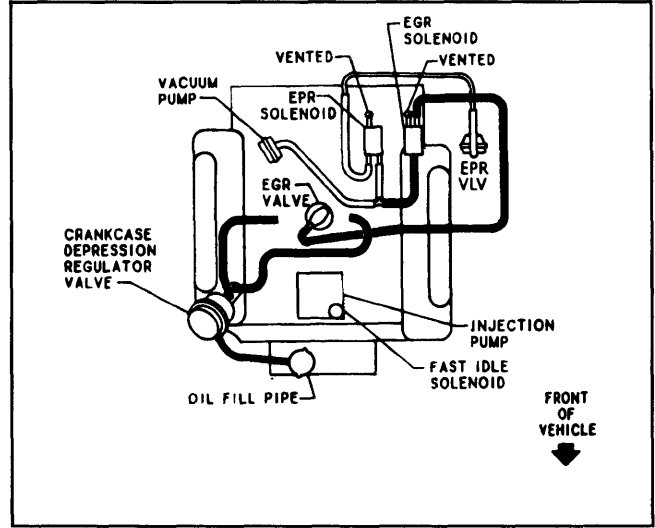

Fig. 44: 6.2L V8 Federal & High Altitude Automatic & Manual Trans. C20, C30, K20 & K30 Models

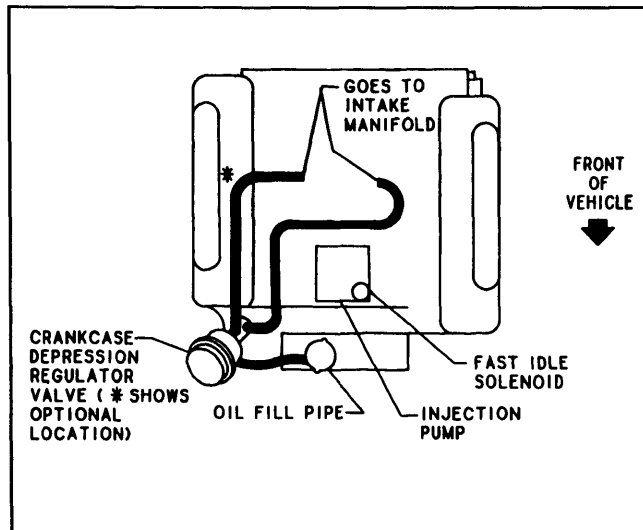

Fig. 47: 7.4L V8 Federal C20, C30, K20 & K30 Models

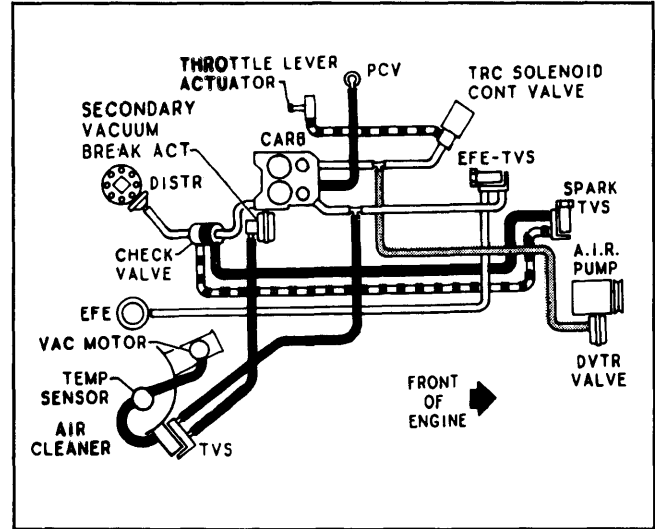

Fig. 45: 6.2L V8 California, Federal & High Altitude Automatic & Manual Trans. C10, C20, K10 & K20 Models

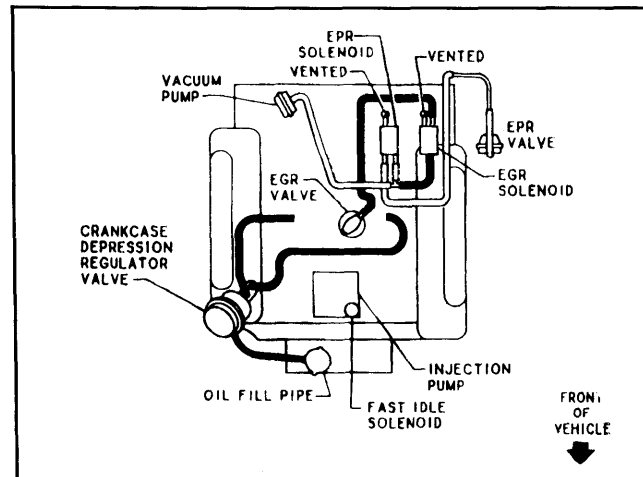

Fig. 48: 7.4L V8 California C20, C30, K20 & K30 Models

