

# 1982 Exhaust Emission Systems

## CHRYSLER CORP. VACUUM THROTTLE POSITIONER

### DESCRIPTION

Some Heavy Duty Emission models have a carburetor equipped with a vacuum throttle positioner. This system prevents unburned hydrocarbon (HC) emissions, during periods of rapid deceleration from high engine speeds.

System consists of an electronic speed switch, a vacuum solenoid valve and a vacuum throttle positioner.

### OPERATION

The electronic speed switch receives an ignition pulse through the ballast resistor, which is connected to electronic ignition control unit. It then senses when engine speed is above 2000 RPM, and energizes throttle positioner.

When energized, throttle positioner plunger extends slightly, holding throttle blades open at 1750 RPM upon sudden deceleration. This prevents an overly rich mixture from flowing into carburetor.

When speed switch senses that engine RPM has dropped below 2000 RPM, it de-energizes positioner and throttle blades return to normal idle position.

### ADJUSTMENT

1) Start engine and accelerate to about 2000 RPM. Verify throttle positioner operation. Throttle positioner must withstand hand pressure. Manually open throttle, until engine speed reaches approximately 2000 RPM. Loosen lock nut, and adjust throttle positioner until it just contacts throttle lever.

2) Release throttle lever. Then, slowly adjust positioner until a sudden drop in speed occurs (over 1000

RPM). At this point, continue adjusting positioner in a decreasing direction for an additional  $\frac{1}{4}$  of a turn, and tighten lock nut. Accelerate engine to approximately 2300 RPM and release throttle. Engine should return to normal idle speed.

### TESTING

1) Check all wiring and hose connections in system. Repair or replace as necessary.

2) Apply vacuum from an external source to vacuum throttle positioner. If positioner does not extend, replace it. If it does, pinch off vacuum hose and observe plunger. If it remains extended for 1 minute or more, unit is okay.

3) Apply external vacuum to manifold supply hose connection on solenoid valve. Disconnect wiring harness from solenoid, and ground 1 terminal of solenoid. Connect 12 volt source to the other terminal, while observing throttle positioner.

4) If plunger does not cycle as voltage is applied, replace solenoid. If it does, replace speed switch.

**Fig. 1: Schematic of Vacuum Throttle Positioner System**

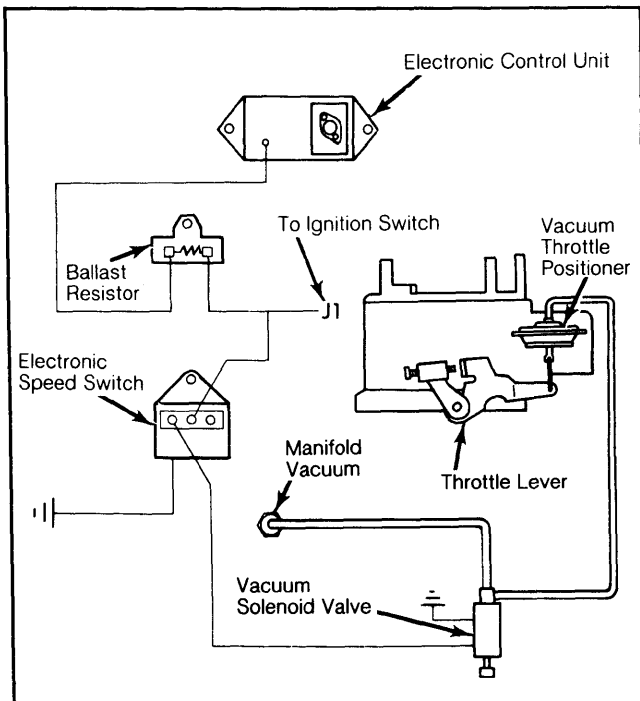

System prevents unburned hydrocarbon emissions during deceleration.