

# 1982 Holley Carburetors

## HOLLEY MODEL 2280 2-BARREL

### CARBURETOR APPLICATION

#### CHRYSLER CORP. (HOLLEY) CARBURETOR NO.

Application	Man. Trans.	Auto. Trans.
5.2L V8		
Federal .....	R-9493-A .....	R-9493-A
	R-9491-A .....	R-9491-A

### CARBURETOR IDENTIFICATION

Carburetor part number is stamped on main body flange. It is in front of the lever, controlled by throttle position transducer, under the choke vacuum diaphragm.

### DESCRIPTION

The Holley model 2280 2 barrel carburetor uses 4 basic fuel metering systems: basic idle system, accelerator pump system, main metering and power enrichment systems.

The basic idle system provides mixture at idle and low speed engine operation. The accelerator pump system provides additional fuel for acceleration. The main metering system provides an economical mixture for normal cruising.

The power enrichment system provides a richer mixture when high power output is required (full throttle operation).

### ADJUSTMENT

**NOTE:** For all on-vehicle adjustments, see TUNE-UP SERVICE PROCEDURES.

#### FLOAT LEVEL

1) With air horn removed, turn main body upside-down. Catch pump intake check ball as it falls out. Hold retainer in place with finger to fully seat float pin in cradle.

2) Using a "T" scale, measure float level specified clearance from air horn gasket surface on main body to toe of each float. See Fig. 1.

Fig. 1: Adjusting Float Level

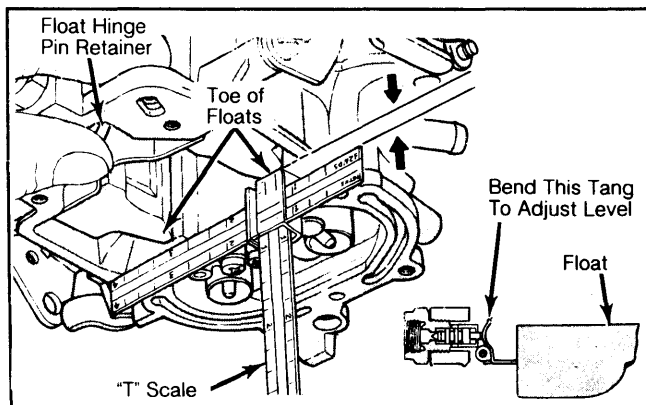

3) To adjust, bend float tang. If necessary, bend either float arm to equalize float positions.

#### ACCELERATOR PUMP STROKE (AT IDLE)

1) Remove bowl vent cover plate and gasket. With all pump links and levers installed, adjust accelerator pump cap nut for zero clearance.

2) Check that wide open throttle can be reached without binding. Install gasket and bowl vent cover plate. See Fig. 2.

**NOTE:** If accelerator pump adjustment is changed, then mechanical power valve must be readjusted.

Fig. 2: Adjusting Accelerator Pump Stroke

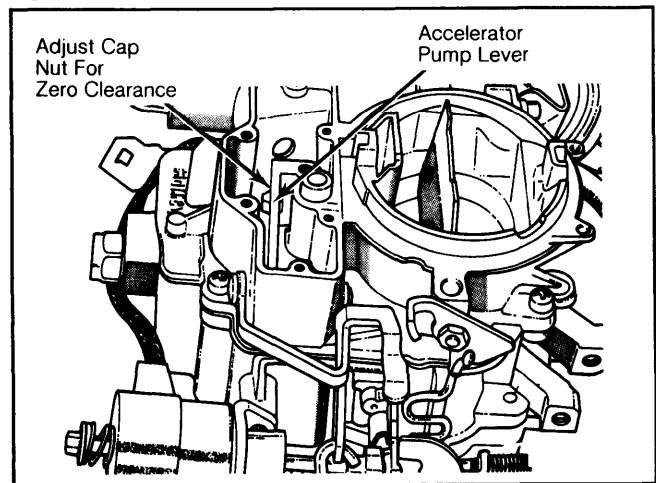

#### CHOKE UNLOADER

1) Hold throttle valves in wide open position. Apply light finger pressure on the choke shaft lever to close choke valve. See Fig. 3.

Fig. 3: Adjusting Choke Unloader

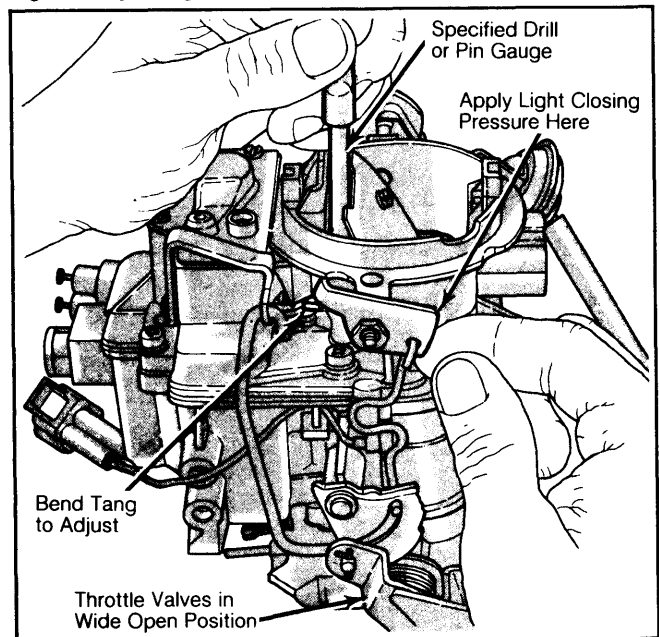

## HOLLEY MODEL 2280 2-BARREL (Cont.)

2) Measure choke unloader specified clearance between upper edge of choke valve and air horn wall. Clearance can be checked, using a specified drill or pin gauge.

3) To adjust, bend choke unloader tang on accelerator pump lever until specified clearance is obtained.

### CHOKE VACUUM KICK

1) Open throttle and close choke. Now close throttle to trap fast idle cam in closed choke position. See Fig. 4.

**Fig. 4: Adjusting Choke Vacuum Kick**

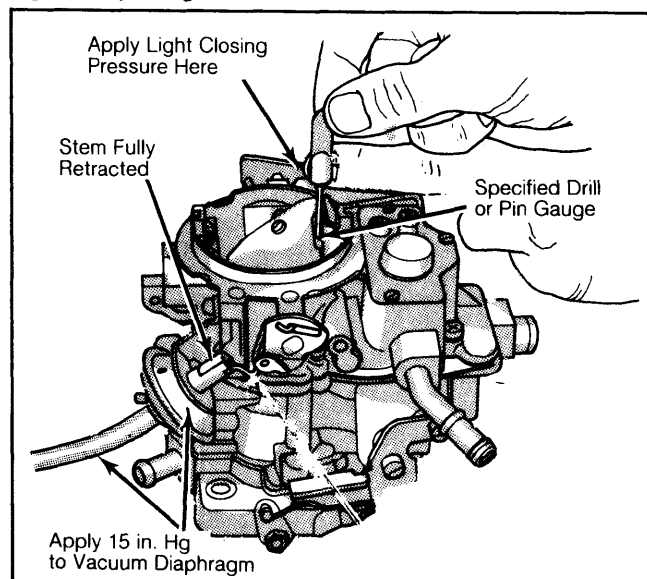

*Spring in diaphragm stem must be compressed during adjustment.*

2) Disconnect vacuum hose from choke vacuum diaphragm. Connect hand vacuum pump to diaphragm, and apply at least 15 in. Hg vacuum. Apply light finger pressure on choke shaft lever to compress spring in diaphragm stem without distorting linkage. Diaphragm stem reaches a stop as spring is compressed.

3) Measure choke vacuum kick specified clearance between upper edge of choke valve and air horn wall. Clearance can be measured using a specified drill or pin gauge.

4) To adjust, insert a  $\frac{5}{64}$ " Allen wrench into choke vacuum diaphragm. Turn adjusting screw to obtain specified clearance. Check all linkage for freedom of movement. Remove vacuum pump, and install vacuum hose on diaphragm.

### FAST IDLE CAM POSITION

1) Position fast idle speed screw on 2nd step of fast idle cam. Apply light finger pressure on choke shaft lever to close choke valve. See Fig. 5.

2) Measure fast idle cam specified clearance, between upper edge of choke valve and air horn wall. Clearance can be measured using a specified drill or pin gauge.

3) To adjust, bend fast idle cam connector rod at existing "U" bend until specified clearance is obtained.

**Fig. 5: Adjusting Fast Idle Cam Position**

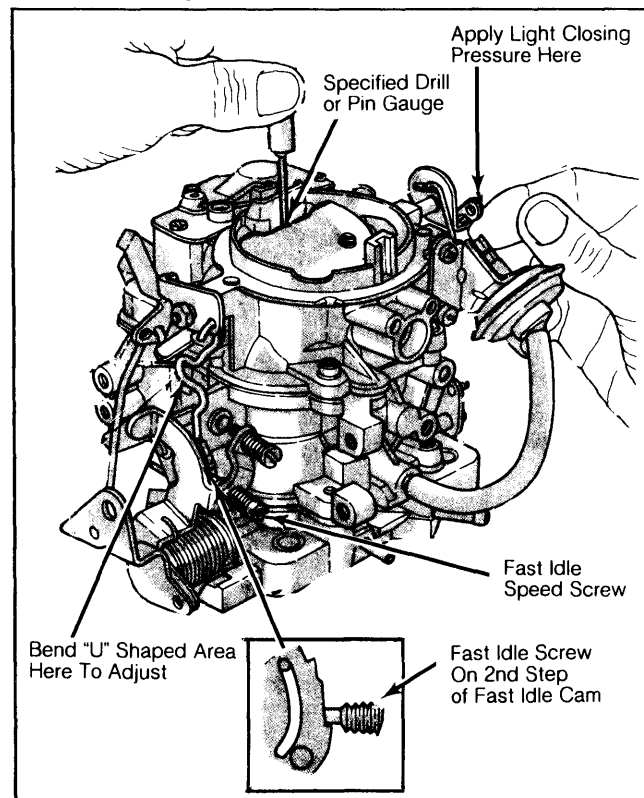

*Place fast idle speed screw on 2nd step of fast idle cam.*

### MECHANICAL POWER VALVE

1) Remove bowl vent valve cover, and hold throttle lever in wide open position. See Fig. 6.

**Fig. 6: Adjusting Mechanical Power Valve**

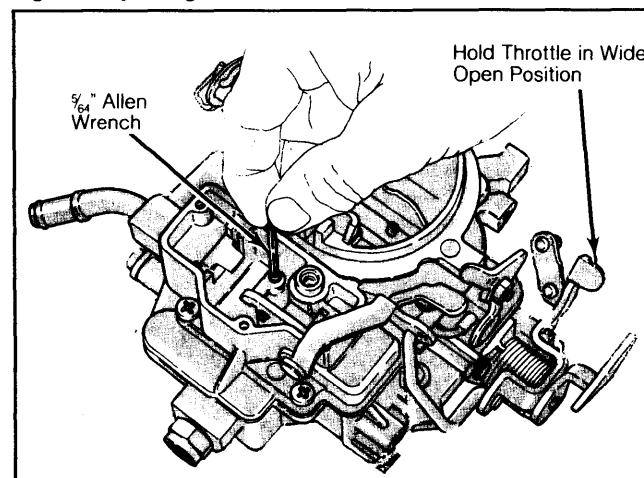

*This adjustment must be reset if accelerator pump adjustment is changed.*

2) Insert a  $\frac{5}{64}$ " Allen wrench in mechanical power valve adjustment screw. Push down on screw, then release to determine if there is any clearance. If so, turn screw clockwise until there is no clearance.

# 1982 Holley Carburetors

## HOLLEY MODEL 2280 2-BARREL (Cont.)

3) To make final adjustment, turn screw counterclockwise 1 full turn from zero clearance. Install bowl vent valve cover plate and gasket.

**NOTE:** If accelerator pump adjustment is changed, mechanical power valve adjustment must be reset also.

### OVERHAUL

#### DISASSEMBLY

1) Position carburetor on a repair stand for disassembly to prevent damage to throttle valves. Remove air cleaner bolt and retainer. Remove accelerator pump link arm.

2) Remove bowl vent cover plate and bowl vent solenoid assembly. Remove choke vacuum diaphragm, linkage, and bracket. Remove electronic throttle control.

3) Remove nut and washer securing fast idle cam lever to choke shaft. Disconnect fast idle cam rod from lever and fast idle cam. Disconnect and remove accelerator operating link.

4) Remove 6 air horn screws. Lift air horn straight up from main body. Remove and discard air horn gasket. Remove bowl vent valve seal. Disconnect spring and lift valve lever, spring and pin out of air horn.

5) Remove accelerator pump operating shaft retaining clip. Pull shaft out straight. Remove accelerator pump arm and internal pump lever. Using a wrench, remove accelerator pump plunger cap nut. Remove accelerator pump plunger.

6) Gently pry up vacuum piston retaining ring tangs. Remove vacuum power valve piston. Remove mechanical power valve push rod and spring assembly by gently prying off plastic cap and removing clip.

7) Remove fuel inlet fitting and gasket. Discard gasket. Remove float hinge pin retainer, hinge pin, float baffle and float assembly. Using a screwdriver, remove main metering jets.

8) Using special tool (C-4231) remove vacuum power valve and mechanical power valve. Make sure blade of tool is squarely seated in slots of valves to avoid damage.

**NOTE:** Do not interchange the mechanical and vacuum power valve assemblies. Mechanical power valve needle is about .050" longer than vacuum power valve needle. The vacuum power valve needle has an undercut groove just above the needle stop. Mechanical power valve is located on choke side of carburetor. Do not mix up valve seats. Assemblies must be reinstalled in original locations, and must be kept with their respective needle and spring assembly.

9) Remove venturi cluster screws. Lift cluster and gasket up and away from main body. Do not remove idle well tubes. Turn main body upside-down and catch accelerator pump weight and check ball.

10) Remove 4 throttle body screws. Separate throttle body from main body, and discard gasket. Remove clip securing fast idle cam, and slide cam off stub shaft.

11) Carefully remove idle limiter caps from idle mixture screws. Remove mixture screws and springs from throttle body.

#### CLEANING & INSPECTION

- Do not soak choke diaphragm or plastic parts in solvent.
- Rinse all metal parts with HOT water after using solvent. Blow dry with compressed air.
- Do not use wire, drill or any hard parts to clean passages and orifices in carburetor.
- Be sure gasket holes match up, and that all parts are clean and ready for installation.
- Test freedom of choke mechanism in air horn. Choke shaft must float freely to operate correctly. If movement is not free, thorough cleaning is required.

#### REASSEMBLY

##### Throttle Body

Install idle mixture screws and springs. Gently seat both mixture screws by hand. Now back out 1 full turn as a preliminary idle mixture adjustment.

##### Main Body

1) Install fast idle cam on stub shaft with steps facing fast idle speed screw. Install retaining clip.

2) Turn main body upside-down. Place throttle body gasket in position. Position throttle body on main body. Install 4 attaching screws, and tighten to 30 INCH lbs. (3 N.m).

3) Install accelerator pump discharge check ball and weight. Fill fuel bowl with clean fuel, and check ball and seat operation. Hold ball and weight down with a small brass rod. Place accelerator pump plunger in well, and operate by hand. If no resistance is felt, check ball is leaking.

4) Remove weight and leave check ball in place. Use a small drift punch, and lightly tap ball against seat to form a new seal. Remove old check ball and discard. Install a new ball and weight.

5) Perform fuel leak test again. If there is still no resistance felt, main body must be replaced. If resistance is felt, check ball is seating correctly.

6) Install new venturi cluster gaskets. Install venturi cluster in position in main body. Install screws and tighten securely.

7) Install main metering jets. Using the same tool as used during disassembly, install mechanical and vacuum power valves. Use care not to damage power valve needles. Ensure valves are installed in original locations as noted during disassembly.

8) Install hinge pin in float. Insert hinge pin through slot in float baffle. Tabs on baffle should point down. Place assembly in pin cradle in main body. Install hinge pin retainer.

9) Install fuel inlet fitting with new gasket. Perform float level adjustment.

##### Air Horn

1) Install vacuum power piston spring and piston. Install retaining ring over piston and carefully seat in place. Check piston operation for binding or sticking. If piston binds or sticks enough to prevent smooth operation, install new piston.

2) Install mechanical power valve push rod spring, rod and retaining clip. Install plastic cap on push rod.

# 1982 Holley Carburetors

## HOLLEY MODEL 2280 2-BARREL (Cont.)

Fig. 7: Exploded View of Holley Model 2280 2-Barrel Carburetor

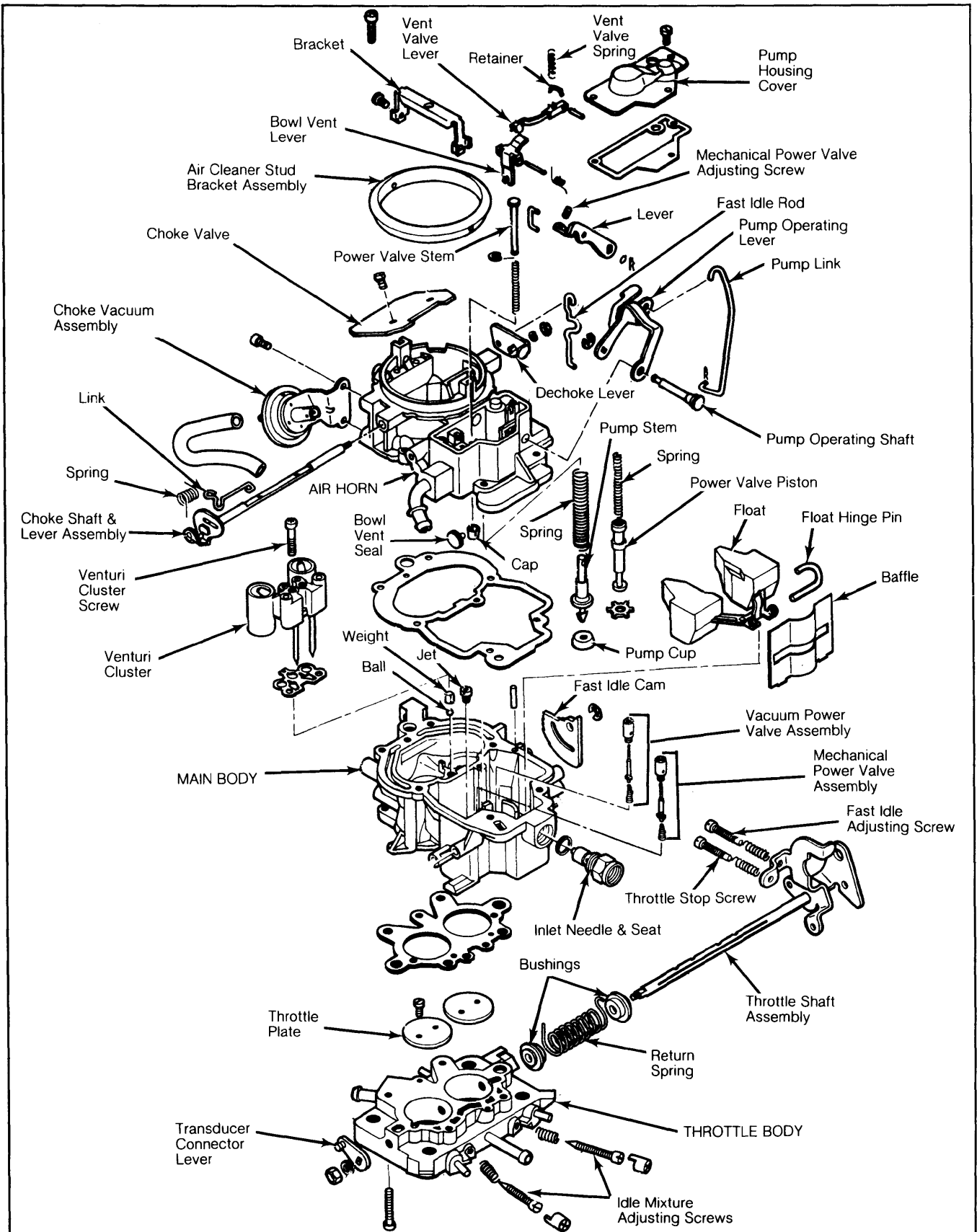

# 1982 Holley Carburetors

## HOLLEY MODEL 2280 2-BARREL (Cont.)

3) Install accelerator pump assembly through air horn and install cap nut.

4) Install new air horn gasket. Carefully lower air horn into position on main body, guiding accelerator pump plunger into its cylinder. Use care not to damage accelerator pump plunger.

5) Install air horn screws. Starting from center and working out, tighten screws to 25 INCH lbs. (2.8 N.m).

6) With pump override spring retainer contacting air horn boss, adjust cap nut for a clearance of .310" between housing surface and cap nut. Install accelerator pump lever and operating shaft.

7) Connect plain end of fast idle cam connector rod to slot in fast idle cam from inside of cam. Engage other end of rod in choke lever. Place choke valve in wide open position. Align flats, and slide choke lever onto choke shaft. Install lock washer and tighten nut.

8) Connect choke vacuum break diaphragm rod to slot in choke lever. Install diaphragm assembly and tighten screws. Install electronic throttle control.

9) Install bowl vent assembly. Using a new gasket, fit bowl vent cover plate to air horn. Install accelerator pump lever, using a new cotter pin. Install air cleaner bolt and retainer.

### CARBURETOR ADJUSTMENT SPECIFICATIONS

Application	Float Level	Accel. Pump	Choke Unloader	Choke Vac. Kick	Fast Idle Cam
R-9491-A	$\frac{9}{32}$ "	Flush <sup>1</sup>	.200"	.140"	.052"
R-9493-A	$\frac{9}{32}$ "	Flush <sup>1</sup>	.200"	.140"	.052"

<sup>1</sup> — Flush with top of bowl vent casting.