

TUNE-UP

ENGINE IDENTIFICATION

The engine can be identified by the eighth digit of the Vehicle Identification Number.

The number is located on the Safety Compliance label on the left front door pillar. It also is located on a metal plate, riveted to the driver's side of the dash and visible through windshield.

VIN ENGINE CODE

| Application | Code |
|-------------------------|------|
| 4.9L (300") 1-Bbl. | E |

TUNE-UP NOTES

NOTE: For other items affecting Tune-Up, see FUEL SYSTEMS Section or EMISSION CONTROL Section.

CAUTION: When performing tune-up on vehicles equipped with a catalytic converter, do not allow or create a condition of engine misfire in one or more cylinders for an extended period of time. Damage to converter from overheating may occur due to loading with unburned fuel.

NOTE: Due to production changes, always refer to Engine Tune-Up Decal in engine compartment before attempting tune-up. In the event of a conflict between specifications given in this manual and decal specifications, use the decal specifications.

NOTE: For tune-up purposes, "Light Duty" refers to vehicles up to 8500 lbs. GVW. "Heavy Duty" refers to vehicles exceeding 8500 lbs. GVW.

NOTE: In some applications within this article it will be necessary to refer to engine calibration number. To determine location of calibration number decal on engine, refer to Ford Motor Co. Vacuum Diagrams in EMISSION CONTROL Section.

ENGINE COMPRESSION

Test compression with all spark plugs removed and engine at normal operating temperature. Crank engine through at least five compression strokes before recording reading. Maximum compression variation should not exceed 25% between highest and lowest cylinder.

COMPRESSION SPECIFICATIONS

| Application | Compression Ratio |
|------------------|-------------------|
| All Models | 8.9:1 |

VALVE CLEARANCE

VALVE CLEARANCE SPECIFICATIONS

| Application | Clearance |
|------------------|--------------------------------------|
| All Models | ¹ .100-.200" (2.5-5.1 mm) |

¹ — Clearance allowable with tappet collapsed. Desired clearance is .125-.175" (3.2-4.5 mm).

VALVE ARRANGEMENT

E-I-E-I-E-I-E-I-E-I (Front to rear)

SPARK PLUGS

SPARK PLUG SPECIFICATIONS

| Application | Gap In. (mm) | Torque Ft. Lbs. (N.m) |
|------------------|-----------------|--------------------------|
| All Models | .044 (1.15) | 12 (16) |

SPARK PLUG TYPE

| Application | Motorcraft No. |
|------------------|----------------|
| All Models | BSF-42 |

HIGH TENSION WIRE RESISTANCE

1) Loosen wires from spark plugs by twisting spark plug boot carefully to loosen seal on spark plug. Remove wires by pulling on plug boot. Remove distributor cap from distributor, leaving wires connected to cap.

2) Using an ohmmeter, check resistance of each wire. Connect one ohmmeter lead to spark plug terminal and other lead to distributor cap insert.

3) Replace any wire with over 5000 ohms resistance per inch. New wires should have a resistance of 7000 ohms per foot.

NOTE: Whenever a high tension wire is disconnected, the interior of spark plug terminal boot must be coated with dielectric silicone grease before reconnection.

DISTRIBUTORS

All models are equipped with Dura Spark II ignition system. No adjustments are required.

Fig. 1: Timing Mark & Firing Order

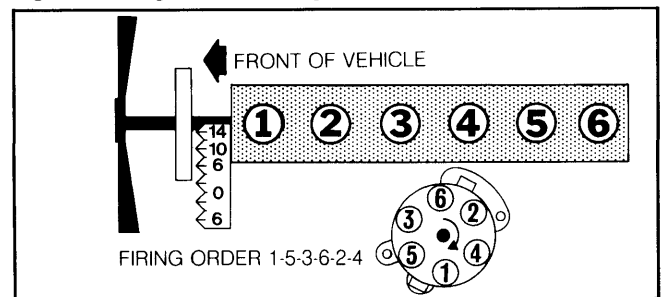

Receptacle for magnetic pick-up timing light is located at 135° ATDC.

1982 Ford 6 Tune-Up

TUNE-UP (Cont.)

IGNITION TIMING

CAUTION: Engines are equipped with a receptacle for use with magnetic pick-up timing lights, located at 135° ATDC. Do not use this location for timing with a conventional timing light.

1) Place transmission in neutral or "Park". Remove vacuum hose from distributor vacuum advance connection, and plug hose. Place mark on proper degree line of damper (or of pointer and damper notch). Connect timing light using inductive pickup or adapter.

2) Do not puncture spark plug leads. Connect an accurate tachometer. If vehicle is equipped with a barometric pressure switch, disconnect it from ignition module. Connect a jumper wire across pins at ignition module connector.

3) Start engine and warm to operating temperature. With engine idling in neutral, check timing. If within 2°, do not reset. If outside specifications, loosen distributor hold-down bolt and rotate distributor to set timing. Recheck after tightening bolt.

IGNITION TIMING (Degrees BTDC@RPM)

| Application | Auto. Trans. | Man. Trans. |
|---------------|--------------|-------------|
| All Models | | |
| Light Duty | | |
| High Altitude | 10°@800 | 10°@800 |
| All Others | 10°@800 | 1 6°@800 |
| Heavy Duty | 12°@800 | 2 12°@800 |

1 — Set Calibration No. 2-51P-R0 to 10°@600 RPM and No. 2-51P-R10 to 12°@600 RPM.
 2 — Set Calibration No. 9-78J-R0 to 10°@800 RPM.

HOT (SLOW) IDLE RPM

LIGHT DUTY

1) Place transmission in neutral or "Park" with engine at normal operating temperature. Turn A/C heat selector off. Allow engine speed to stabilize, and measure curb idle speed. Ensure TSP is activated. Adjust RPM by turning nut directly behind dashpot housing. See Fig. 2. Check anti-diesel RPM (TSP-Off).

2) Manually collapse the TSP-dashpot by rotating the carburetor shaft lever until TSP-Off adjusting screw contacts the carburetor body. Place transmission in neutral. Increase engine RPM momentarily, and then recheck idle RPM.

3) If final curb idle speed adjustment is required, bowl vent setting must be checked. Stop engine, and turn ignition key to "ON" position.

4) Secure the choke plate in the wide open position. Open the throttle so that throttle vent lever does not touch fuel bowl vent rod. Close the throttle, and measure the travel of fuel bowl vent rod at point "A" from the open position. See Fig. 3.

5) Travel should be within .100-.150" (2.5-3.8 mm). If out of specification, bend the vent lever to obtain required travel. Move A/C heat selector to maximum cooling (blower switch in high position). Disconnect A/C clutch wire. Check and adjust for A/C-On RPM.

Fig. 2: Adjustment Points for YFA 1-Bbl. Carburetor on Light Duty Engines

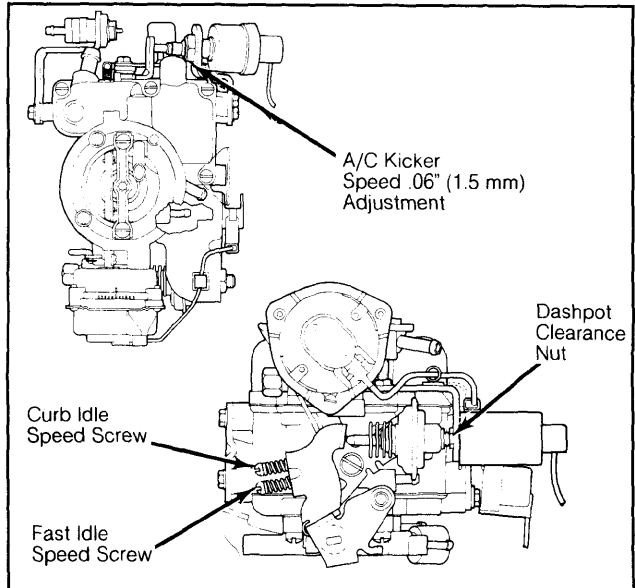

Use 3/8" end wrench on dashpot clearance nut.

Fig. 3: Bowl Vent Setting

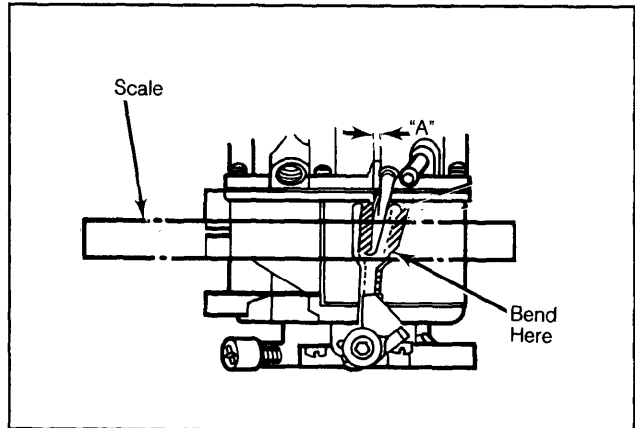

Bend throttle vent lever to adjust setting.

LIGHT DUTY IDLE SPEED (RPM)

| Application | Curb Idle (A/C Off) | Solenoid Energized (A/C On) |
|-------------|---------------------|-----------------------------|
| All Models | | |
| Man.Trans. | 600 | 700 |
| Auto.Trans. | 550 | |

HEAVY DUTY

1) Place transmission in neutral or "Park", with engine at normal operating temperature. Turn A/C heat selector off.

2) Activate Throttle Solenoid Positioner (TSP). Set curb idle to specification by screwing solenoid in or out. See Fig. 4.

TUNE-UP (Cont.)

Fig. 4: Adjustment Points for YFA 1-Bbl. Carburetor on Heavy Duty Engines

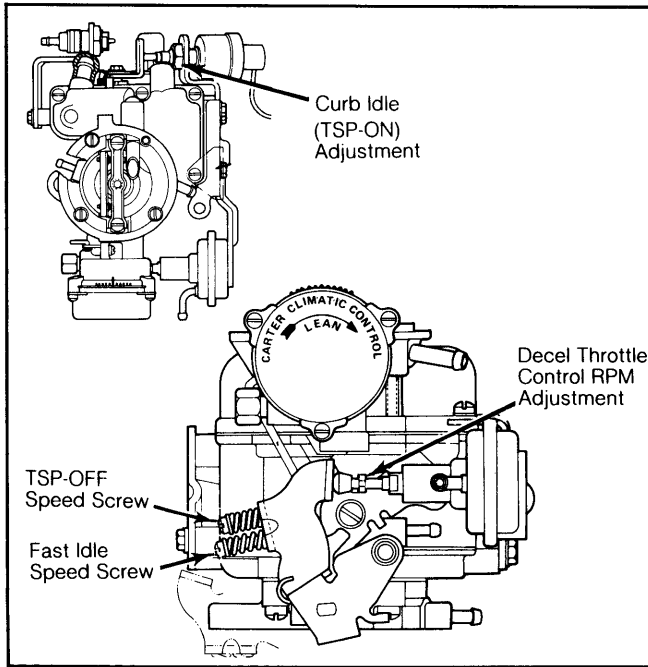

A/C heat selector must be "OFF."

3) With transmission selector lever in either neutral or "Park" position, increase engine speed momentarily, letting it return to normal curb idle. Check RPM, and readjust if required.

4) If final curb idle speed adjustment is required, bowl vent setting must be checked. Stop engine and turn ignition key "ON". Secure the choke plate in the wide open position.

5) Open the throttle so that throttle vent lever does not touch fuel bowl vent rod. Close the throttle and measure the travel of fuel bowl vent rod at point "A" from the open position.

6) Travel should be within .100-.150" (2.5-3.8 mm). If out of specification, bend the vent lever to obtain required travel. To set TSP-Off RPM, run engine to normal operating temperature.

7) Place A/C heat selector in "OFF" position. Disconnect TSP wire. Place transmission in neutral. Using TSP-Off adjusting screw, set TSP-Off RPM to specifications. Reconnect TSP wire to terminal.

HEAVY DUTY IDLE SPEED (RPM)

| Application | Curb Idle (TSP-On) | TSP-Off |
|------------------|--------------------|---------|
| All Models | | |
| Man.Trans. | 600 | 500 |
| Auto.Trans. | 550 | 500 |

COLD (FAST) IDLE RPM

LIGHT DUTY

1) Place transmission in neutral. Bring engine to normal operating temperature. Disconnect vacuum

hoses at EGR, purge valve or purge solenoid valve, and plug hoses.

2) Disconnect vacuum hose from cold start vacuum switch (orange vacuum switch on valve cover). Plug hose. Using a slave vacuum hose, connect manifold vacuum to cold start vacuum switch.

3) Place fast idle screw on second step (kickdown) of fast idle cam. Adjust fast idle speed to specifications. See Fig. 2. Remove plugs from vacuum hoses, and restore all hoses to their original locations.

LIGHT DUTY FAST IDLE SPEED (RPM)

| Application | RPM | Cam Step |
|-------------------|------|----------------|
| All Models | | |
| Man. Trans. | 1400 | 2nd (Kickdown) |
| Auto. Trans. | 1400 | 2nd (Kickdown) |

HEAVY DUTY

NOTE: Procedure includes setting Decel Throttle Control.

1) Place transmission in neutral. Bring engine to normal operating temperature. Disconnect and plug vacuum hose at EGR valve and decel throttle control diaphragm.

2) Place fast idle adjusting screw on second step (kickdown) of fast idle cam. Adjust fast idle speed to specifications. Momentarily depress throttle to rotate fast idle cam.

3) Using a slave vacuum hose, connect manifold vacuum to decel throttle control diaphragm. Adjust diaphragm shaft length until specified RPM is obtained. Remove plugs, and restore vacuum hoses to their original locations.

HEAVY DUTY FAST IDLE SPEED (RPM)

| Application | Fast Idle Speed | Decel Throttle Control Speed |
|-------------|-----------------|------------------------------|
| All Models | 1600 | 1400-1500 |

IDLE MIXTURE

NOTE: If adjustments to the air/fuel mixture are made that require removing the idle limiter caps, it is imperative that the BLUE SERVICE LIMITER CAPS be installed. Idle mixture should be adjusted only during carburetor repair or when necessary as a result of government inspection laws.

PROPANE ENRICHMENT PROCEDURE

1) Leave all vacuum signal hoses attached to air cleaner assembly when relocating air cleaner for carburetor adjustments. Air cleaner MUST be installed for engine speed checks.

NOTE: Propane enrichment procedure is for Light Duty Vehicles only. For adjustments for Heavy Duty Vehicles, see Emission Control Tune-Up Decal.

1982 Ford 6 Tune-Up

TUNE-UP (Cont.)

1) Leave all vacuum signal hoses attached to air cleaner assembly when relocating air cleaner for carburetor adjustments. Air cleaner **MUST** be installed for engine speed checks.

CAUTION: Do not let engine idle for extended periods, as catalyst overheating may cause excessive underbody temperatures.

2) Apply parking brake and block wheels. Disconnect automatic brake release, and plug vacuum connection. Connect tachometer.

3) Disconnect and plug fuel evaporative purge valve signal hose at engine. Disconnect purge hose at air cleaner and plug nipple.

4) Disconnect flexible fresh air tube from air cleaner duct or adapter. Insert hose from propane enrichment tool (Rotunda T75L-9600-A) about $\frac{3}{4}$ of the way into duct or fresh air tube. Disconnect PCV valve from grommet, and allow valve to draw underhood air during adjustment.

5) For vehicles equipped with thermactor, disconnect and plug hoses of dump valves equipped with 2 fittings. If valves have one fitting, remove and plug hose at valve. Connect slave hose to dump valve and intake manifold vacuum source.

6) Verify ignition timing is set to specification and adjust if necessary. With engine at normal operating temperature, check curb idle speed or A/C-Off RPM. Adjust as necessary. Run engine at 2500 RPM for 15 seconds before each mixture check.

7) With engine idling in neutral, gradually open propane tool valve and watch for engine speed gain on tachometer. When speed reaches maximum and begins to drop off, note amount of speed gain.

NOTE: Propane cartridge must be in vertical position. If engine speed will not drop off, check bottle gas supply. If necessary, repeat test with new bottle.

8) Compare measured speed gain with specifications. If mixture adjustment is necessary, adjust so gain is within "Reset RPM" specifications. If propane enrichment speed gain is within "RPM Gain" specifications, proceed to step 11).

9) If measured speed gain is greater than specification, turn mixture screws counterclockwise in equal amounts, and recheck until measured speed rise is within "Reset RPM" specifications. Then proceed to step 11).

10) If measured speed gain is less than specification, turn mixture screws clockwise in equal amounts, and recheck until measured speed rise is within "Reset RPM" specifications.

11) Check curb idle, and remove all test equipment. Reconnect hoses in original positions, and connect PCV valve.

IDLE MIXTURE SPECIFICATIONS (PROPANE ENRICHMENT)

| Calibration Number ¹ | RPM Gain (Check) | Reset RPM (Adjust) |
|---------------------------------|------------------|--------------------|
| Light Duty | | |
| 2-52K-R0 & | | |
| 2-52L-R0 | 20-110 | 60 |
| All Others | 10-50 | 20 |

¹ — Calibration No. is located on an identification label on front of valve cover. On some engines, label may be on same component as Emission Certification Decal.

AUTOMATIC CHOKE ADJUSTMENT

NOTE: Some models may have tamper-proof choke assemblies.

Drill heads from 2 rivets, and remove. Loosen retaining screw, and turn choke cover in direction indicated on cover to specified setting. Install new rivets and tighten screw.

AUTOMATIC CHOKE SPECIFICATIONS

| Application | Choke Setting |
|------------------|----------------|
| Light Duty | Non-Adjustable |
| Heavy Duty | Index |

FUEL PUMP

Check fuel pump at idle RPM with engine at normal operating temperature.

FUEL PUMP SPECIFICATIONS

| Application | Pressure psi (kg/cm ²) | Volume Pints (Liters) |
|------------------|------------------------------------|----------------------------------|
| All Models | 5.0-7.0 (.35-.50) | 1 in 30 sec. (.47 in 30 sec.) |

EMISSION CONTROL

NOTE: See appropriate article in EMISSION CONTROL Section.

GENERAL SERVICING

IGNITION

DISTRIBUTOR

All units are equipped with Motorcraft Dura-Spark II Ignition system. Units are self-contained and require no outside adjustments.

DISTRIBUTOR PICK-UP COIL RESISTANCE (Ohms)

| | |
|------------------|----------|
| All Models | 400-1000 |
|------------------|----------|

1982 Ford 6 Tune-Up

GENERAL SERVICING (Cont.)

TOTAL SPARK ADVANCE@2500 RPM

| Calibration No. | W/Vac. Advance | W/O Vac. Advance |
|-----------------------------|----------------|------------------|
| Light Duty | | |
| 2-51K-R0 ¹ | 38-49° | 13-18° |
| 2-51X-R0, | | |
| 2-51Y-R0 | 46-57° | 17-22° |
| All Others | 42-53° | 13-19° |
| Heavy Duty | 24-32° | 18-23° |

¹ — Also Nos. 2-52K-R0, 2-52S-R0, 2-52G-R0, 2-51L-R0, 2-52L-R0 and 2-52T-R0.

IGNITION COIL

COIL RESISTANCE (Ohms)

| Application | Primary | Secondary |
|------------------|---------------|-------------|
| All Models | 0.8-1.6 | 7700-10,500 |

FUEL SYSTEMS

CARBURETORS

| Application | Model |
|-------------------------|----------------------------|
| Light Duty | |
| Federal | Carter YFA 1-Bbl. |
| Calif. & High Alt. | Carter YFA 1-Bbl. Feedback |
| Heavy Duty | Carter YFA 1-Bbl. |

ELECTRICAL

BATTERY

BATTERY SPECIFICATIONS

| Application | Capacity (Amp. Hours) | Discharge Rate (Amps.) |
|------------------|-----------------------|------------------------|
| Standard | | |
| Federal | 36 | 155 |
| California | 45 | 190 |
| Optional | 54, 63, 81 | 225, 260, 175 |

STARTER

All models use Motorcraft positive engagement type starters with either a 4" or 4½" armature.

STARTER SPECIFICATIONS

| Application | Volts | Amps. | Test RPM |
|--------------------|----------|----------|-----------|
| 4" Armature | 12 | 70 | 6700 Min. |
| 4½" Armature | 12 | 80 | 7380-9356 |

ALTERNATORS

All models use Motorcraft alternators.

ALTERNATOR SPECIFICATIONS

| I.D. Tag Color | Rated Amp. Output |
|----------------|-------------------|
| Rear Terminal | |
| Orange | 40 |
| Green | 60 |
| Side Terminal | |
| Black | 70 |
| Red | 100 |

Field Current Draw@12 Volts

| | |
|------------------|-----------|
| All Models | 4.0 Amps. |
|------------------|-----------|

ALTERNATOR REGULATORS

Two Motorcraft electronic voltage regulators are used. Although both look alike, they are not interchangeable.

REGULATOR IDENTIFICATION

| Application | Color Coding |
|--------------------------------|--------------|
| Used with Ammeter | Blue label |
| Used with Indicator Lamp | Black label |

ADJUSTMENTS

BELT ADJUSTMENT

| Tension Using Strand Tension Gauge | |
|------------------------------------|-----------------|
| Application | Lbs. (Kg) |
| New Belt | |
| ¼" Belt | 50-80 (23-36) |
| Air Conditioning | 135-145 (61-66) |
| Alternator | 120-160 (54-72) |
| All Others | 120-130 (54-59) |
| Used Belt ¹ | |
| ¼" Belt | 40-60 (18-27) |
| Air Conditioning | 90-100 (41-45) |
| Alternator | 90-120 (41-54) |
| All Others | 70-80 (32-36) |

¹ — Any belt operated 10 minutes or more.

SERVICE INTERVALS

REPLACEMENT INTERVALS

| Application | Miles |
|------------------------------|--------|
| Oil Filter | |
| E100, E150, F100, F150 | 10,000 |
| Bronco | 7500 |
| All Others | 15,000 |
| Air Filter | 30,000 |
| PCV Filter | 30,000 |
| Spark Plugs | 30,000 |

1982 Ford 6 Tune-Up

GENERAL SERVICING (Cont.)

CAPACITIES

FLUID CAPACITIES (EXCEPT FUEL & COOLING)

| Application | Quantity |
|------------------------------------|------------------------------|
| Crankcase | ¹ 6.0 qts. (5.6L) |
| Rear Axle (Hypoid Gear Lube) | |
| Ford Standard & Traction-Lok | 6.5 pts. (3.0L) |
| Dana 60 | 5.0 pts. (2.4L) |
| Dana 61-1 | 6.0 pts. (2.8L) |
| Dana 61-2 | 6.0 pts. (2.8L) |
| Dana 70 | |
| Standard | 6.5 pts. (3.0L) |
| Heavy Duty | 7.4 pts. (3.5L) |
| Front Axle (Hypoid Gear Lube) | |
| Dana 44-IFS | |
| F150 & Bronco | 3.9 pts. (1.8L) |
| F250 | 3.8 pts. (1.8L) |
| Dana IFS | 4.1 pts. (1.9L) |
| Transfer Case (Dexron II Series D) | |
| Warner 1345 | 6.5 pts. (3.0L) |
| New Process 208 | 7.0 pts. (3.3L) |
| Auto. Trans. (Dexron II) | |
| C-5 3-Speed | 22 pts. (10.4L) |
| C-6 3-Speed | |
| 2-WD | 24 pts. (11.2L) |
| 4-WD | 27 pts. (12.7L) |
| AOT 4-Speed | 24 pts. (11.7L) |
| Man. Trans. (SAE 80W-90) | |
| Ford 3.03 3-Speed | 3.5 pts. (1.6L) |
| T-18 4-Speed | 7.0 pts. (3.3L) |
| New Process 435 4-Speed W/Ext. | 7.0 pts. (3.3L) |
| New Process 435 4-Speed W/O Ext. | 6.5 pts. (3.0L) |
| 4-Speed Overdrive | 4.5 pts. (2.1L) |

¹ — Includes 1 qt. (.95L) for filter change.

FUEL TANK CAPACITIES

| Application | Gallons (Liters) |
|-------------------------------------|------------------|
| F100, F150, F250 (Short W.B.) | |
| Standard | 16.5 (62.4) |
| Auxiliary | 19.0 (72.0) |
| F100, F150, F250, F350 (Long W.B.) | |
| Standard | 19.0 (72.0) |
| Auxiliary | 19.0 (72.0) |
| E100, E150, Club Wagon (Short W.B.) | |
| Standard | 18.0 (68.1) |
| Auxiliary | 18.0 (68.1) |
| All Other "E" Models (Long W.B.) | |
| Standard | 22.1 (83.7) |
| Auxiliary | 18.0 (68.1) |
| Bronco | |
| Standard | 25.0 (94.6) |
| Optional | 32.0 (121.1) |

COOLING CAPACITIES

| Application | Quarts (Liters) |
|-------------------------|-----------------|
| "E" Models ¹ | |
| With Heater | 15.0 (14.2) |
| With Heater & A/C | 20.0 (18.9) |
| Bronco & "F" Models | |
| With Heater | 13.0 (12.2) |
| With Heater & A/C | 14.0 (13.2) |

¹ — Add .8 quart (.76L) for auxiliary heater.