

## CHRYSLER CORP. COMBUSTION CONTROL COMPUTER

Imperial

### DESCRIPTION

The Combustion Control Computer (CCC) system is used on Imperial models with Electronic Fuel Injection. The computer controls the EFI system, spark timing and advance, idle speed, air injection switching and fuel evaporation purging.

The system is capable of self-calibration to compensate for changes in altitude or barometric pressure. It also has safety features that enable it to shut down the fuel supply pump if the engine stalls or will not start after prolonged cranking.

### COMBUSTION CONTROL COMPUTER

The computer is located in a housing attached to the air cleaner. No servicing is possible and the housing should not be opened. The system inputs and outputs are routed through 2 connectors — one a 10-pin and the other a 12-pin.

The CCC has 4 main circuits which control engine operation. These are the EFI circuit, which monitors air/fuel ratios; the Auto Calibration Circuit, which fine-tunes and corrects the EFI; the Electronic Spark Advance (ESA) circuit, which controls ignition power and advance; and the Automatic Idle Speed (AIS) circuit which controls engine idle speed.

Two other modules are used that have controlling capability. One is the Power Module, located on the hydraulic support plate inside the air cleaner. The power module converts 12 volt battery power to 23 volts for use by the CCC and EFI circuits. It also amplifies signals from the CCC to the EFI control pump, and feeds the flowmeter signal to the CCC.

The other module is the Automatic Shut-Down (ASD) Module and is located on the right fenderwell or firewall. All electrical power to the system flows through the module when the ignition switch is in "Start" or "Run". If the switch is in "Start" position, the ASD module allows the fuel pump to run. When the switch is in "Run" position, the ASD module allows the pump to run unless an ignition signal is not received, in which case it stops the pump within 1/2 second. This prevents flooding or fire hazards. If the injectors were to be damaged, allowing fuel to flow out during cranking, the pump will stop within 20 seconds to prevent the manifold from filling with fuel.

### ENGINE SENSORS

The CCC needs sensor inputs to determine engine operating characteristics. The following sensors are used with this system:

- Intake Airflow Sensor
- Intake Air Temperature Sensor
- Fuel Flowmeter
- Fuel Pressure Switch
- Throttle Position Potentiometer
- Closed Throttle Switch (with Back-up Circuit)
- Coolant Temperature Sensor
- Oxygen Sensor
- Engine Speed (from a distributor signal)
- Air Conditioner "On" Switch

In addition to these sensors, the CCC also receives information from the ignition switch, has a timer to determine operating time, and determines engine load by comparing airflow with engine speed.

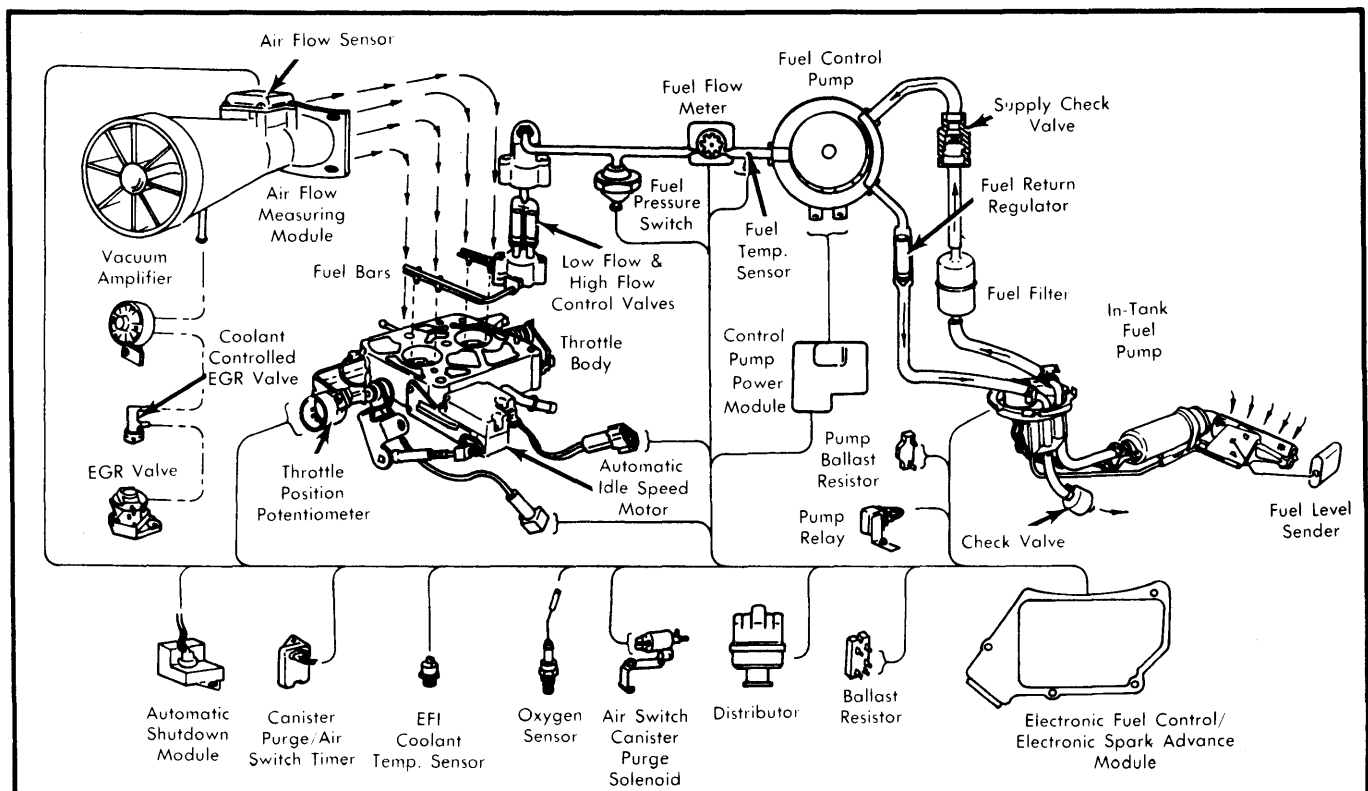

Fig. 1 Combustion Control Computer System Schematic

## CHRYSLER CORP. COMBUSTION CONTROL COMPUTER (Cont.)

### OPERATION

#### COMBUSTION CONTROL COMPUTER (CCC)

The CCC operates in open and closed loop. When the engine is cold or just being started, the system is in open loop operation. This means it operates based on information stored in the CCC programming. When the engine is warm and all conditions are favorable (sensors operating) then it operates in closed loop, where fuel enrichment is based on information from the oxygen sensor.

A unique feature of the Chrysler Combustion Control Computer system is its ability to calibrate itself. The Auto Calibration Circuit compares information with the oxygen sensor to see if it is the same as pre-programmed information would be under the same conditions. If these 2 sources of information do not agree (due to temperature or altitude variations) the computer will adjust its memory to compensate. This calibration takes place at idle speed and around 55 miles per hour during steady cruising.

The electronic Spark Advance circuit is similar to other Chrysler Corp. vehicles. It provides no advance at idle or up to 1000 RPM, provides pre-programmed advance at other engine speeds, and adds additional advance based on engine load and throttle position. A single pick-up distributor is used, with no mechanical advance system.

#### EGR SYSTEM

The CCC system controls engine emission systems, but is not directly in control of EGR operation. A vacuum signal from the airflow sensor and one from manifold vacuum are compared by the vacuum amplifier to determine the proper amount of EGR. A coolant/sensor valve prevents the vacuum signal from reaching the EGR valve until engine coolant temperature is at least 59-64°F. When the valve opens, vacuum is applied through a 1-second delay valve to ensure smooth EGR valve operation.

#### AIR INJECTION SYSTEM

The CCC system uses a 3-way catalytic converter to reduce harmful emissions. The rear half of the converter needs additional oxygen to operate, so the air injection system is designed to supply air to the converter as well as the exhaust manifold.

During warm-up, the system supplies air to the exhaust manifold, which helps to complete combustion in the manifold, and heats the oxygen sensor rapidly. When the sensor has reached operating temperature, air can no longer be supplied to the manifold, since the additional oxygen would "fool" the oxygen sensor, preventing it from determining mixture.

An air switching timer (on Firewall) is used by the CCC to provide air switching. As soon as the engine coolant sensor indicates to the computer that coolant is warm, it starts a 70 second timer. At the end of 70 seconds, a signal is sent to a vacuum solenoid, which allows vacuum to operate the air switching valve. Air is directed "downstream" to the converter. If the engine is warm when started, the 70 second timer is started immediately. See Fig. 3.

### EVAPORATION CONTROL SYSTEM

The evaporation control system (ECS) is used to prevent fuel vapors from entering the atmosphere after the engine is stopped. Vapors that are emitted from the engine and fuel tank when it is stopped are channeled to a canister. When the engine starts, they cannot be immediately purged (drawn into the engine) or the air/fuel mixture will be too rich. However, when the oxygen sensor is operating, it can compensate for the vapors.

The ECS system operates in conjunction with the air switching system. When air injection is shifted downstream, the vacuum signal which keeps the canister purge valve closed is shut off. Engine vacuum draws vapors out of the canister and into the engine, where they are burned. When the engine is stopped, vapors again flow from the engine and fuel tank to the canister. See Fig. 3.

### CRANKCASE VENTILATION

When the engine is operating, crankcase pressure is used to purge vapors through the PCV valve into the throttle body. Air to vent the crankcase is drawn through a hose from the air cleaner to the right valve cover. This operation is similar to non-EFI vehicles. However, since all the air entering the engine is measured through the airflow sensor, any leaks in the PCV system will cause leaning of the mixture and poor driveability.

### DIAGNOSIS & TESTING

#### NOTES & CAUTIONS

**NOTE** — A Chrysler Corp. EFI Tester is necessary to do thorough testing of the CCC systems. However, some checks can be done visually and with normal shop equipment. All electrical measurements must be made with a digital, high-impedance volt-ohmmeter.

**NOTE** — The following tests are performed without the use of an EFI tester. When further testing is required with an EFI tester, follow the equipment manufacturer's instructions and testing procedures.

**CAUTION** — Use extreme care when disconnecting and connecting electrical connectors. Be sure system is off and all connections are made firmly. Otherwise, damage may occur to CCC or additional problems may be introduced into system.

**CAUTION** — If engine must be cranked with ignition coil high tension lead removed from distributor cap, this lead **MUST** be grounded or CCC will be destroyed.

**NOTE** — EFI system is pressurized. Be sure all fittings are tight and check for leaks before operating fuel supply system.

**NOTE** — Whenever CCC is replaced, Auto-Calibration procedure must be performed to allow computer to adjust to vehicle conditions. See "Adjustment" in this article.

Before beginning diagnosis and testing, be sure to check systems that are not related to CCC and eliminate these from the list of possible problems. Such items as corroded battery wires, poor ground connections, and contaminated fuel filters

## CHRYSLER CORP. COMBUSTION CONTROL COMPUTER (Cont.)

or spark plugs will cause problems, but are not the fault of the CCC system.

### SYSTEM VISUAL CHECK

**Inside The Air Cleaner** — 1) Proper wires connected to control pump, fuel pressure switch, and fuel flowmeter. See Fig. 4 (wiring diagram) for wire identification and routing.

2) Power module ground wire connected to support plate screw. Fuel lines and pressure switch connected tight and not leaking.

3) No wires are cut or chafed by clips or hardware. Air cleaner cover tightly sealed.

**NOTE** — *The EFI system measures air to calculate fuel flow and will not operate if the air cleaner cover is removed. Ensure that cover is sealed except when observing fuel flow during cranking.*

**Outside The Air Cleaner** — 1) All electrical connections are tight and wires are in good condition. All electrical component mounting screws must be clean and tight to ensure good ground connection.

2) Vacuum hoses connected between PCV valve and front throttle body port; charcoal canister and rear throttle body port. All other vacuum lines connected and in good condition.

3) Check fuses for EFI and in-tank pump. Check connection from in-tank pump to body harness near tank.

### NO-START CHECKS

1) Remove air cleaner. Disconnect coil secondary wire and connect it to ground. Crank engine and check for fuel flow at injectors. If flow is okay, check ignition system.

**CAUTION** — *Coil secondary wire must be grounded if not connected to cap while engine is being cranked. Otherwise, damage to computer may occur.*

2) If no fuel is seen, perform "In-Tank Pump Test". If fuel flow is minimal, perform "Fuel Pressure Test". If fuel flow is excessive or evidence of flooding is seen, perform "Excessive Fuel Flow" test.

**Ignition System Test** — 1) Hold secondary coil wire  $\frac{3}{16}$ " from good ground and crank engine. If a good spark is seen, repair cap, rotor, or secondary wires. If no spark is seen, go to next step.

2) Remove 10-pin connector from CCC and connect ohmmeter across pins 5 and 9 in connector. If resistance is between 150-900 ohms, pick-up coil is okay. Check resistance between pin 9 and ground and pin 5 and ground. If resistance is very high, no short exists. If resistance is low, check for short between pick-up coil and computer.

3) If resistance of pick-up coil is zero, coil is shorted or grounded. Check at distributor connector for continuity between either connector wire and ground. If grounded, replace coil and attempt restart. If coil is not grounded, go to step 5).

4) If resistance at pick-up coil is too high, check again across the 2 terminals in the distributor connector. If resistance is now between 150-900 ohms, repair circuit to computer. If not, the

harness is okay and the pick-up coil must be replaced. Attempt restart.

5) Voltage at coil positive terminal (during cranking) should be 9 volts or more. If not, check voltage at starter relay "BAL" terminal while cranking. If voltage is 9 volts or more, repair circuit to coil. If not, check battery and/or replace starter relay.

6) If voltage at coil terminal is 9 volts or more and engine will not start, disconnect 10-pin connector at computer and connect voltmeter between pin 1 in connector and ground. While cranking engine, voltage should be 9 volts or more. If not, repair wiring harness and attempt restart. If so, go to next step.

7) Connect ohmmeter between pin 10 and ground. If continuity is not shown, repair ground connection to pin 10. If continuity is shown, disconnect ASD module and repeat step 1). If a good spark is shown, replace ASD module. If not, replace CCC.

**In-Tank Pump Test** — 1) Check continuity and resistance of in-tank pump ballast resistor. Resistor is at right top of cowl and should have 0.4 ohms resistance.

2) Continuity should be present between one side of ballast resistor and pin 3 of pump relay connector (right fender well). Continuity should exist between other side of resistor and pin 1 in connector. Pin 5 should be grounded.

3) Insert positive voltmeter probe into rear of relay connector at pin 3 while connector is hooked up. Connect other probe to ground and crank engine. Voltmeter should indicate 8-10 volts. Insert probe at pin 4 and crank engine. Voltmeter should indicate 9 volts. If not, check battery and supply to pump relay.

4) If voltage is present, check continuity between pin 3 of relay connector and Dark Green wire at pump (fuel tank).

**Fuel Pressure Test** — 1) Check battery for at least 12 volts. Connect pressure gauge to "T" at fuel supply fitting on fuel plate. Crank engine.

2) Fuel pressure should be at least 8 psi. If not, check fuel pick-up, fuel filters, fuel lines or blocked vent lines.

**Excessive Fuel Flow** — 1) With air cleaner cover removed, turn key on. If fuel flows continuously from injectors, disconnect control pump connector.

2) If fuel continues to flow, replace fuel control plate (pump, injectors, flowmeter).

3) If fuel flow stops, problem is in computer. Substitute good computer and retest. If original proves defective, replace computer.

### STARTS, THEN STALLS CHECKS

**AIS Motor** — 1) Turn ignition on but do not start engine. Visually check position of throttle arm at AIS motor. Arm should be pointing downward and toward rear of engine.

2) If throttle arm is in correct position, check ballast resistor. With ignition on, measure voltage between pin "A" and ground, then between pin "B" and ground. Voltage at "A" should be 6 volts, at "B", 10 volts. If not, check wiring harness.

3) Resistance (with connectors removed) between pins "C" and "D" should be 9-11 ohms, and between "D" and "E" should be 4-6 ohms. If not correct, replace ballast resistor.

## CHRYSLER CORP. COMBUSTION CONTROL COMPUTER (Cont.)

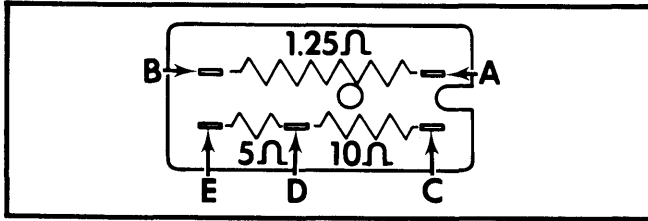

**Fig. 2 Ignition/AIS Motor Ballast Resistor Connections**

4) If arm at motor was in correct position, disconnect 10-pin connector at computer. Connect a voltmeter between pin 6 of connector and ground. At least 8 volts should be present. If not, check wiring harness. If harness is okay, replace AIS motor.

5) If 8 volts were measured at pin 6, computer must be replaced.

**Fuel Supply** — Perform test under "No-Start Checks" and inspect fuel flow, fuel pressure, and voltage to pump.

**Computer Supply** — 1) Disconnect 12-pin EFI connector from module inside computer on air cleaner housing. Connect a voltmeter between pin 8 of connector and ground, then crank engine.

2) Voltmeter should indicate at least 9 volts. If not, reconnect connector and check wiring harness to starter relay. If voltage is correct, replace computer.

### DRIVEABILITY CHECKS

**Preliminary Check** — 1) Connect tachometer and adjustable timing light to engine. Start engine and allow to idle. Idle speed should be between 530-630 RPM. If not, adjust idle speed using EFI tester.

2) Ground closed throttle switch using jumper wire. Timing light should indicate 12° BTDC. If not, adjust basic timing. Raise engine RPM to 1500 RPM with switch still grounded. If

timing changes, CCC must be replaced. If timing does not change, go to next step.

3) Remove jumper wire from closed throttle switch and decrease engine speed to 1000 RPM. Timing should be 27-35°. If not, replace CCC. If so, proceed to next step.

4) Increase engine speed to 2000 RPM. Timing should be 47-55°. If not, replace CCC. If so, engine has passed preliminary test. Other testing must be done with EFI tester.

**Air Switching Operation** — 1) Engine must be warm. Stop engine and disconnect downstream air hose from air switching valve. Start engine, noting time with stop watch. For first 70 seconds, no air should come from downstream port of air switching valve. If okay, go to step 3). If air is emitted, check harness and connectors at CCC and air switching timer.

2) If connections are good, connect voltmeter between ground and air switching vacuum solenoid feed wire (leave feed wire connected). If voltage is less than 1 volt and air comes from valve, replace air switching valve. If voltage is about 12 volts and air comes from valve, replace air switching timer.

3) After 70 seconds following engine start, air should come from downstream port of air switching valve. If so, and driveability is still poor, replace CCC and retest. If no air comes from valve (and voltage at solenoid is less than 1 volt), check electrical connections.

4) If connections are good, replace air switching timer. If voltage is above 12 volts and no air comes from downstream port, check vacuum hoses and source. If good, replace air switching valve and retest.

### ADJUSTMENT

#### THROTTLE POSITION POTENTIOMETER (TPP)

**NOTE** — Throttle position potentiometer is mounted with break-off screws. Screws must be drilled and removed, then replaced before adjustment is possible.

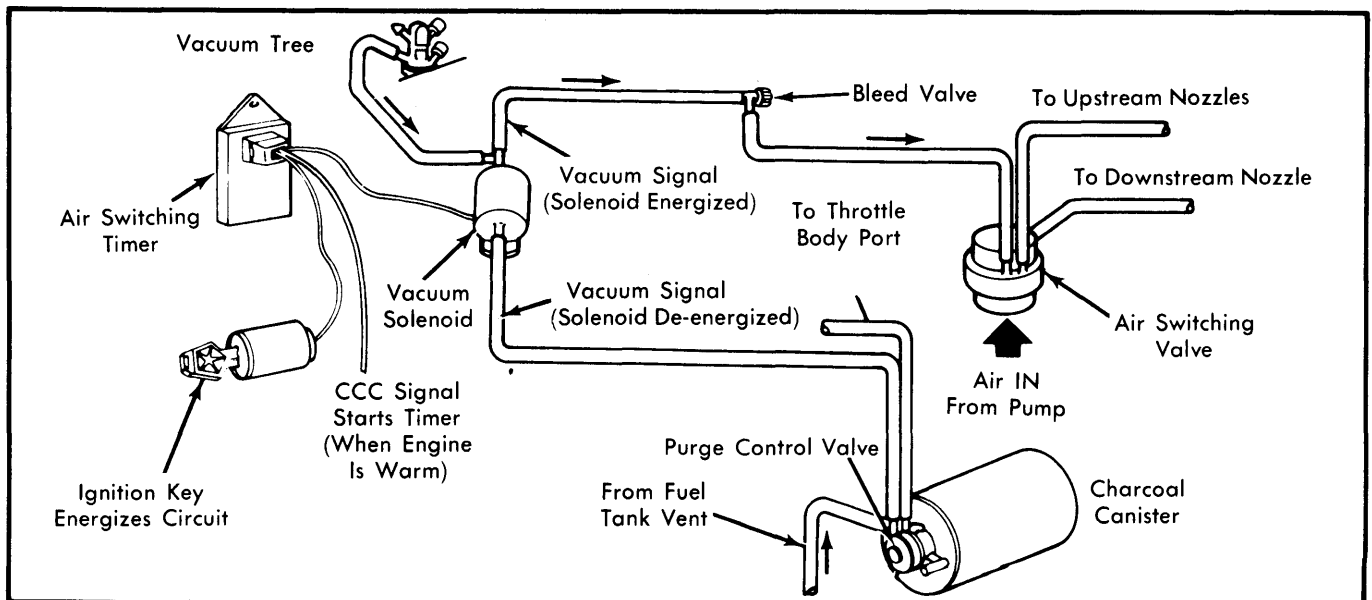

**Fig. 3 Air Switching/Canister Purging Circuits**

# 1a-48 1982 Computerized Engine Controls

## CHRYSLER CORP. COMBUSTION CONTROL COMPUTER (Cont.)

- 1) Connect EFI tester to vehicle. Place toggle switch to EFI position and rotary switch to throttle position, then turn ignition on. Move diagnostic aid switch to manual position, then move AIS control switch down and hold until AIS motor stops.
- 2) Depress AIS by-pass button and read TPP voltage. Adjust switch position to obtain 4.0-5.0 volts. Tighten break-off screws until heads snap off.

### AUTOMATIC IDLE SPEED MOTOR

- 1) Turn ignition on. Motor should move arm rearward and open throttle blades. When vehicle is started, idle should be 580 RPM in "D" and should remain constant. If not, adjustment may be necessary.
- 2) Connect EFI tester with diagnostic aid. Connect tachometer pick-up to No. 1 spark plug lead, battery leads to battery, and place diagnostic aid switch to normal position.
- 3) Start engine and run until warm. Move diagnostic aid switch to manual and depress control switch until engine speed no longer decreases. Place transmission selector in "D".
- 4) Idle speed should be 530-630 RPM. If not, adjust to 580 RPM by turning screw on end of AIS motor linkage. One turn of screw will change idle speed 50 RPM.

### AUTO-CALIBRATION

**NOTE** — Whenever computer is replaced, auto-calibration procedure must be performed to allow computer to adjust to vehicle conditions.

- 1) Start and run engine until normal operating temperature is reached. If engine is already warm, idle for at least 90 seconds to allow timer to run out.
- 2) Increase speed to 2000-2500 RPM and hold constant for at least 90 seconds. Reduce engine speed to idle and allow to idle for at least 150 seconds.
- 3) Repeat step 2) once more so computer can verify initial calibration. Procedure is now complete.

### CALIBRATION VERIFICATION

**NOTE** — This procedure can be used to verify that the computer is operating properly. Engine must be at normal temperature.

- 1) Air cleaner cover must be tight and exhaust system must be checked to ensure no leaks or holes exist. Connect EFI tester to system and connect a CO meter to tailpipe.
- 2) Remove air pump hose from downstream air injection tube and plug tube. Connect diagnostic aid to AIS motor. Start engine, leave transmission selector in "P", and place speed control switch in manual position. Idle for at least 90 seconds.
- 3) Disconnect oxygen sensor wire and ground wiring harness side of connector. Increase engine speed to 2000-2500 RPM and hold it constant with diagnostic aid control.
- 4) CO reading must be between 0.5-3.5%. If higher than 3.5%, replace computer.
- 5) Remove test equipment and reconnect air injection tube.

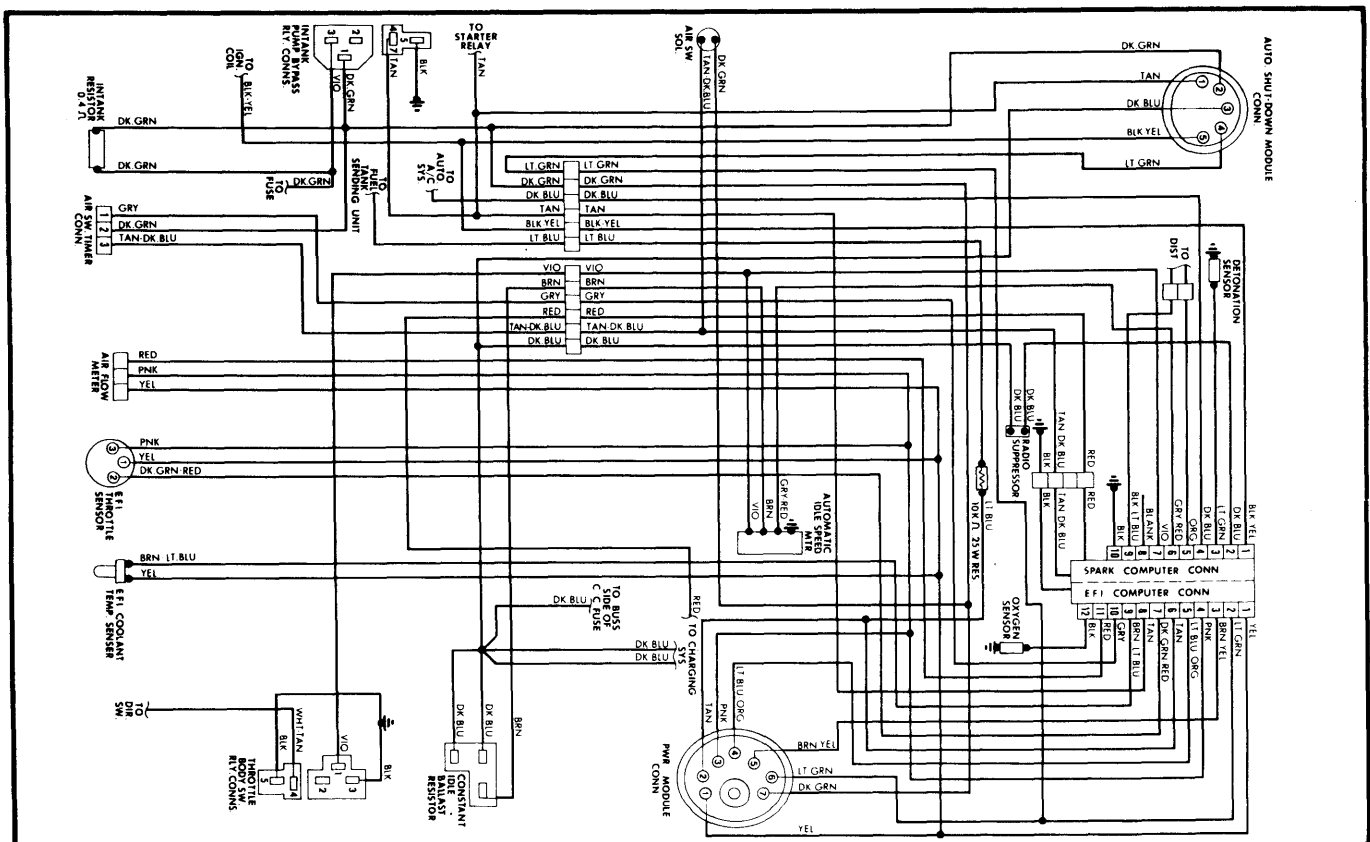

Fig. 4 Combustion Control Computer Wiring Diagram