

1a-20 1982 Computerized Engine Controls

AMERICAN MOTORS 6-CYL. COMPUTERIZED EMISSION CONTROL

American Motors (6-Cyl. Only)

DESCRIPTION

The Computerized Emission Control system (CEC) is an electronically controlled system that closely controls air/fuel ratio to lower exhaust emissions while maintaining good fuel economy and to control the AIR injection system. Primary objective of the CEC system is to maintain an ideal air/fuel ratio of 14.7:1 under all operating conditions. When ideal ratio is maintained, the catalytic converter can effectively control NO_x, HC and CO.

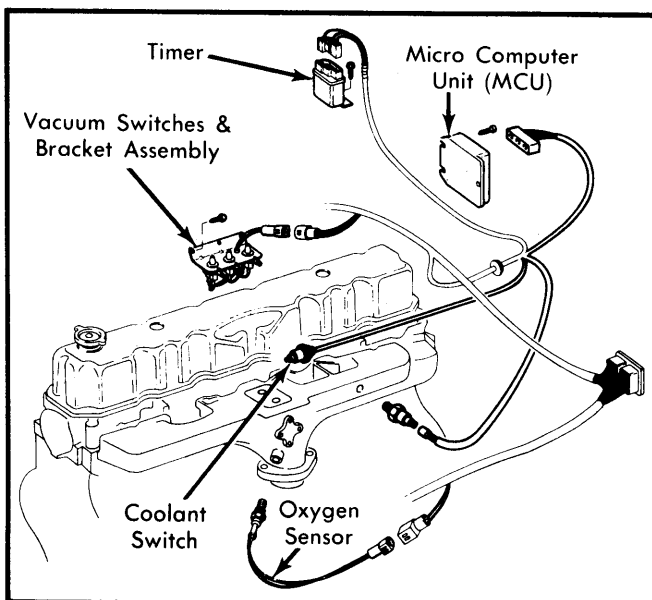

Fig. 1 American Motors 6-Cyl. CEC System

OPERATION

The CEC system consists of 5 sub-systems: Fuel control, data sensors, Micro Computer Unit (MCU), catalytic converter and diagnostic system.

FUEL CONTROL

All models are equipped with feedback carburetors which contain an electronically operated stepper motor. The stepper motor controls the metering pins that vary the size of idle and main air bleed orifices in carburetor body. The stepper motor moves the pins in and out of the orifices in steps, in response to signals received from MCU. The motor has a range of 100 steps, but normal operating area is mid-range.

When the metering pins are "stepped" in direction of orifices, the air/fuel mixture becomes richer. When the pins are "stepped" away from orifices, mixture becomes leaner.

DATA SENSORS

Oxygen Sensor — The oxygen sensor is located in the exhaust manifold to measure oxygen content of exhaust gases. As more oxygen is sensed (lean mixture indication), electrical signal

generated by sensor drops in voltage. A lower oxygen content (rich mixture indication) causes an increase in voltage signal output.

Thermal Electric Switch (TES) — This switch is attached inside air cleaner to provide either a ground circuit for MCU to indicate necessity for cold weather engine start-up (air temperature below calibrated value) or an open circuit to indicate normal start-up (air temperature above calibrated value).

Adaptive Vacuum Switch (AVS) — This switch is mounted in a bracket with 2 other vacuum switches on right inner fender panel. The AVS is controlled by manifold vacuum and is normally closed. When closed, this switch indicates an engine idle condition.

Open Loop 1 (OL1) Coolant Temperature Switch — This switch is an integral component of the intake manifold heater coolant temperature control switch. This switch is controlled by coolant temperature and is normally closed. When open, the switch indicates engine is cold (less than 160°F).

Open Loop 2 (OL2) Mechanical Switch — This switch is an integral part of the Wide Open Throttle (WOT) switch, located at the base of carburetor. The OL2 switch is mechanically controlled and has a normally closed electrical switch which is opened by 3.5-4.5" Hg vacuum.

Open Loop 3 (OL3) Vacuum Switch — This switch is mounted on the same bracket as the AVS switch. This switch is controlled mechanically and has a normally closed electrical switch (indicating a closed throttle position). The electrical switch is opened with 2.5-3.5" Hg of carburetor ported vacuum.

Open Loop 4 (OL4) Vacuum Switch — This switch is mounted on same bracket as the AVS switch and is controlled by manifold vacuum. This switch is normally open. When open, the switch indicates a near full throttle condition.

Wide Open Throttle Switch (WOT) — This mechanically operated electrical switch is located on carburetor and is controlled by the throttle position to indicate a wide open throttle condition. This switch is normally open.

Engine RPM Voltage — This voltage is supplied from the tach terminal on the distributor. Until a voltage equal to a predetermined RPM is received by the MCU, the system remains in open loop mode of operation. The result is a fixed rich air/fuel mixture for engine starting.

Timer — This timer is activated whenever system is operating in open loop 2 mode (wide open throttle). This timer remains active for a preset period of time. If a "lean limit" condition (altitude jumper wire installed) occurs, the timer becomes inoperative. The timer has multi-function abilities, in addition to OL2 mode, it is used as a WOT timer and start-up timer.

MICRO COMPUTER UNIT (MCU)

The MCU is located in passenger compartment, behind right-hand kick panel. The MCU monitors the CEC system data sensors and, based upon mode of operation, generates an output

1982 Computerized Engine Controls 1a-21

AMERICAN MOTORS 6-CYL. COMPUTERIZED EMISSION CONTROL (Cont.)

control signal to the stepper motor mounted in carburetor. The MCU allows the following 3 modes of operation:

Initialization — This function occurs when ignition switch is turned on. This sets initial air bleed metering rod position by signaling the stepper motor to drive them first to a full rich position (fully toward front of vehicle) and then, by a pre-programmed number of steps, in lean direction (toward rear of vehicle). This serves as a starting point of mixture control operation.

Open Loop — In this mode, the MCU determines the air/fuel mixture based upon engine operation rather than oxygen sensor input signals. There are 5 open loop modes of operation and each has a specific metering pin position. However, because each condition may be present at the same time, the MCU is programmed with a priority ranking for each operation. The MCU complies with the highest priority. The open loop priorities (listed from highest to lowest) are as follows:

- **Cold Weather Start-Up & Operation** — If air cleaner air temperature is below calibrated value of TES, the stepper motor positions the metering pins a pre-determined number of steps richer than that at initialization. Air injection is diverted "upstream". Lean air/fuel mixtures are not permitted for a preset period, following a cold weather start.
- **Open Loop 2 (Wide Open Throttle)** — Open Loop 2 (OL2) is selected whenever air cleaner air temperature is above calibrated value of the TES and the WOT switch has been engaged. In OL2 mode, the stepper motor drives the metering pins to a calibrated number of steps rich of initialization and the air control valve diverts air "downstream". The timer is activated in this mode.

NOTE — If a "lean limit" condition (altitude jumper wire installed) is selected, the air is diverted "upstream". The timer is inoperative if "lean limit" is selected.

- **Open Loop 4** — This mode is selected whenever manifold vacuum falls below a preset value. During OL4 operation, the stepper motor is positioned at the initialization position. Air injection is switched "upstream"; however, air is diverted "downstream" if the extended OL4 timer is activated or "lean limit" (altitude jumper wire) is not installed. Air is also diverted "downstream" if the WOT timer is activated.
- **Open Loop 3** — This mode is selected when spark advance vacuum level falls below a preset level. In OL3 mode, engine RPM is also determined. If the RPM voltage is greater than the calibrated value, an engine deceleration condition is assumed to exist. If the RPM voltage is less than calibrated value, an engine idle condition is assumed to exist.

NOTE — Both deceleration and idle conditions are independently selectable to be either an open loop or closed loop condition. If selected as an open loop operation, air is diverted "upstream".

- **Open Loop 1** — This mode will be selected if air cleaner temperature is above calibrated value, OL2, OL3 or OL4 is not selected and if engine coolant temperature is below calibrated value. The OL1 mode operates instead of normal closed loop operation during cold engine operating

condition. In this mode, 1 of 2 pre-determined metering pin positions are chosen, dependent if the "lean limit" (altitude circuit) jumper wire is installed.

NOTE — With each engine start-up, a start-up timer is activated. During this interval, if engine operating condition would otherwise trigger normal closed loop operation, OL1 mode is selected.

- **Open Loop Position Variation** — An additional function of the MCU is to correct for a change in ambient conditions (altitude). During closed loop operation, the MCU stores the number of steps and direction that the metering pins are driven to correct oxygen content of exhaust gases. If the movements are consistently to the same position, the MCU will vary all open loop operation preset metering pin positions a corresponding amount. This function allows the open loop air/fuel mixture ratios to be adjusted to the existing ambient condition during each uninterrupted use of the system. This is to optimize emission control and engine performance.

Closed Loop — When all input data and engine operation meet programmed criteria (after OL1, OL2, OL3 and OL4 modes have been selected and start-up timer has deactivated), the CEC system goes into closed loop operation. In this mode, oxygen sensor input signals are accepted by MCU to determine proper air/fuel mixture based upon oxygen content of exhaust gases. Air injection is routed "downstream" during this mode to aid in oxidation of HC and CO. The pre-determined "lean mixture ceiling" is selected for a preset length of time at the start of closed loop operation.

NOTE — Closed loop operation is characterized by constant movement of the metering pins. The MCU is constantly making small corrections in air/fuel ratio in an attempt to create the ideal air/fuel ratio.

CATALYTIC CONVERTER

Proper emission control is accomplished with the special catalytic converter used with the CEC system. All models, except Federal Eagle models, use a dual bed monolithic-type converter with "downstream" air injection. The injection of air between the 2 beds, allows more complete oxidation of HC and CO in the closed loop mode. Federal Eagle models are equipped with a pellet-type converter. In order for these converters to be effective, precise control of the oxygen content of gases entering converter is necessary, thus the need for the oxygen sensor, MCU and feedback carburetor.

TESTING

The steps listed in the following charts will provide a systematic evaluation of each component that could cause a malfunction. After completing a repair, repeat the test to ensure that the malfunction has been eliminated.

If after completing any test procedure and the problem persists, other engine associated systems that can affect air/fuel mixture, combustion efficiency or exhaust gas composition may be causing the fault. These systems include:

AMERICAN MOTORS 6-CYL. COMPUTERIZED EMISSION CONTROL (Cont.)

- Basic carburetor adjustments.
- Mechanical engine operation (plugs, valves, rings).
- Ignition system.
- Intake manifold, carburetor or base plate gaskets.
- Loose vacuum hoses or fittings.

Test Equipment – 1) The test equipment required to perform the tests include: Tachometer, hand vacuum pump, digital volt-ohmmeter with a minimum 10 megohm impedance and jumper wires.

2) Before beginning any of the tests, a clear air cleaner cover must be fabricated from clear acrylic plastic at least .25" thick. This is secured with air cleaner wing nut after top of air cleaner has been removed to observe operation and position of metering pins. See Fig. 2.

NOTE – The metering pins operate in tandem. Only the upper pin is visible.

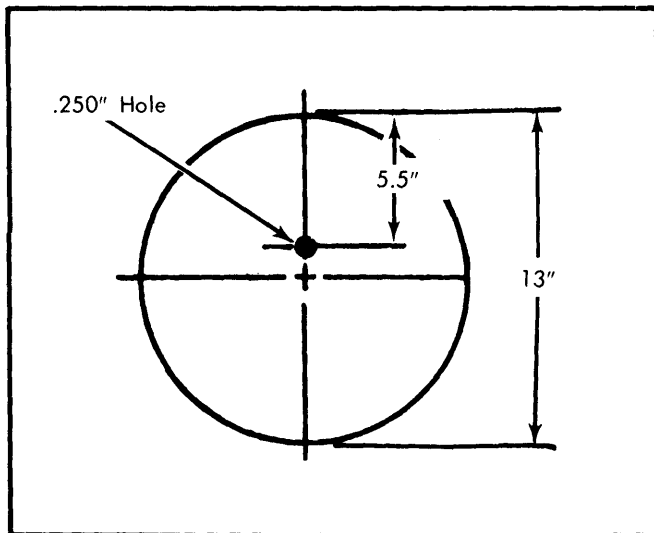
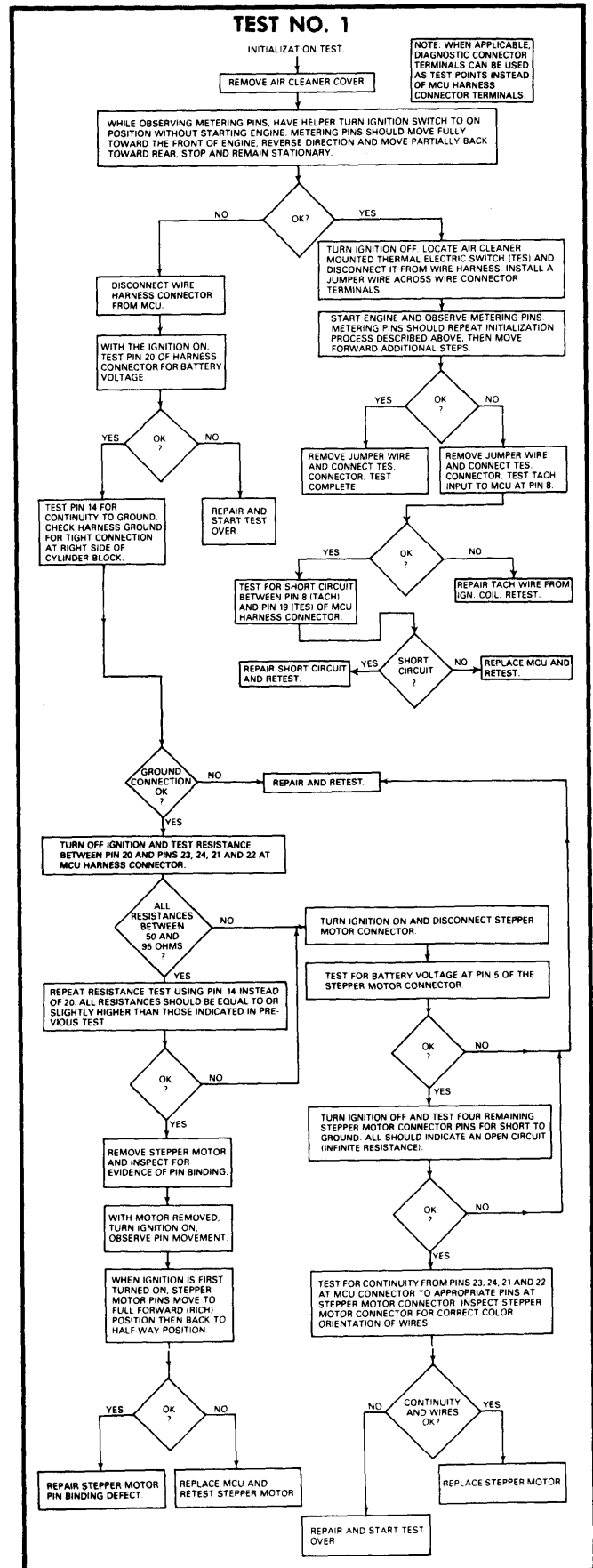

Fig. 2 Dimensions for Fabricating Clear Air Cleaner Cover for Observing Metering Pins

TEST CHARTS

Chart	Condition
No. 1	Initialization test.
No. 2	Open loop switch test.
No. 3	Closed loop operational test.
No. 4	Electronic ignition retard test.
No. 5	Oxygen sensor and closed loop test.
No. 6	Air injection system test.
No. 7	Divert solenoid test.
No. 8	Upstream solenoid test.
No. 9	Idle speed control system test.
No. 10	Sole-Vac vacuum switching solenoid test.
No. 11	Sole-Vac idle speed relay test.
No. 12	Basic engine test.



1982 Computerized Engine Controls 1a-23

AMERICAN MOTORS 6-CYL. COMPUTERIZED EMISSION CONTROL (Cont.)

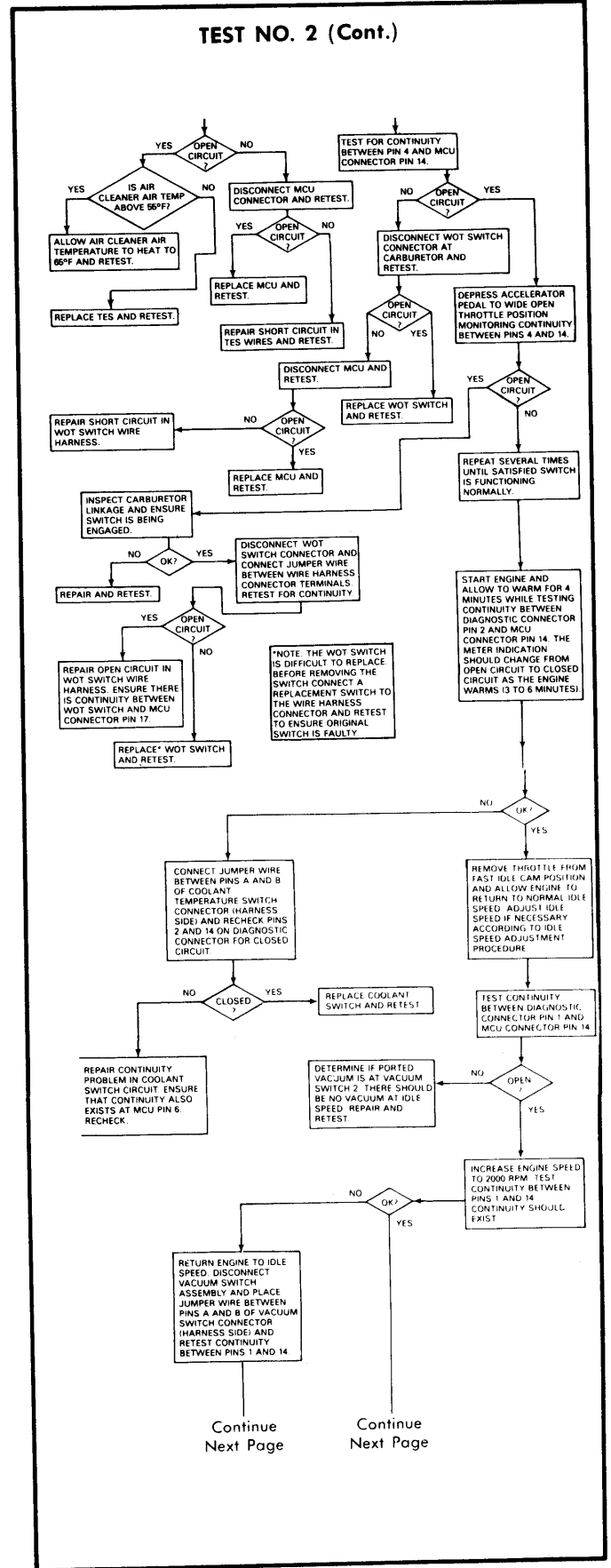
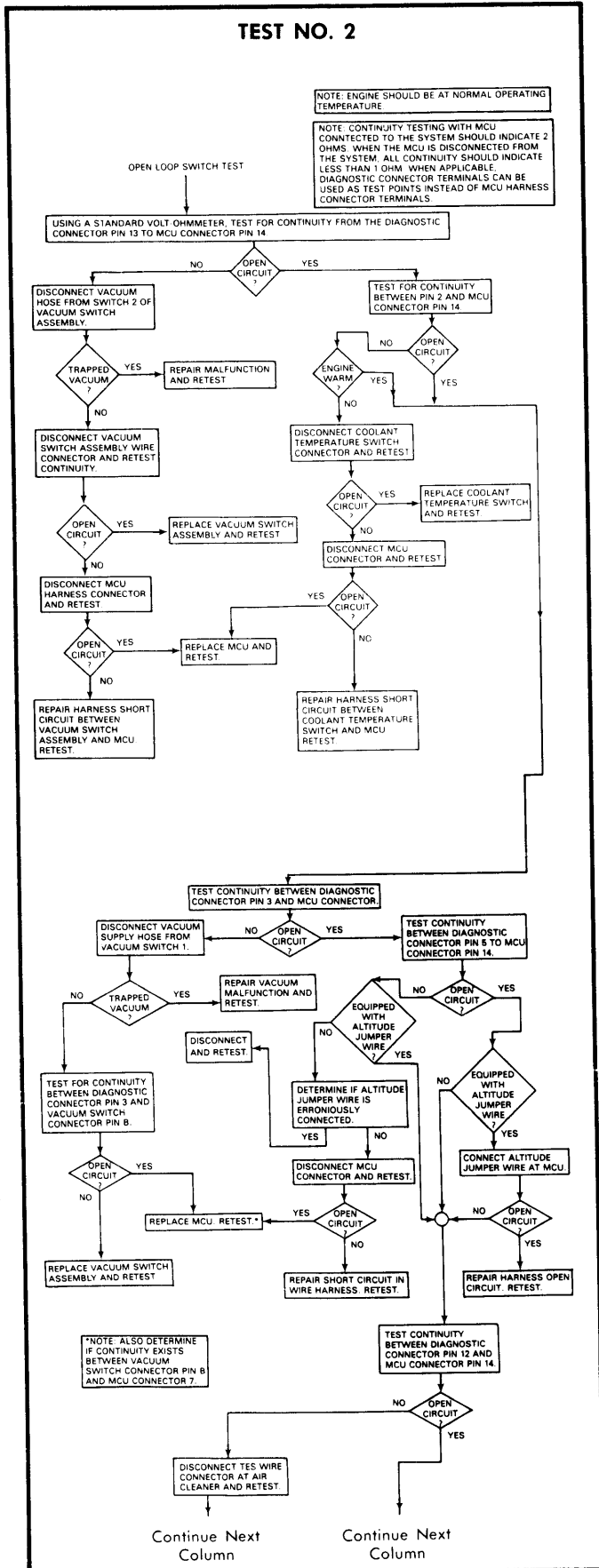

1a-24 1982 Computerized Engine Controls

AMERICAN MOTORS 6-CYL. COMPUTERIZED EMISSION CONTROL (Cont.)

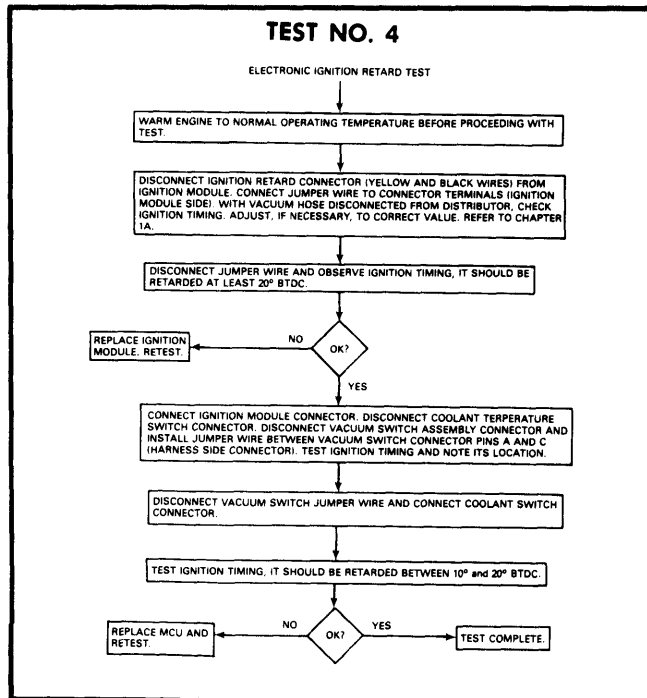
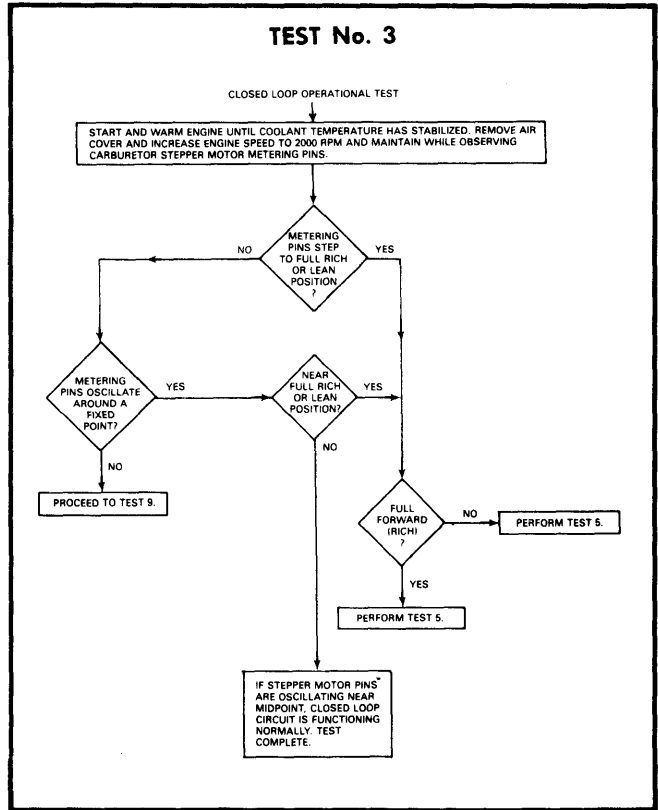
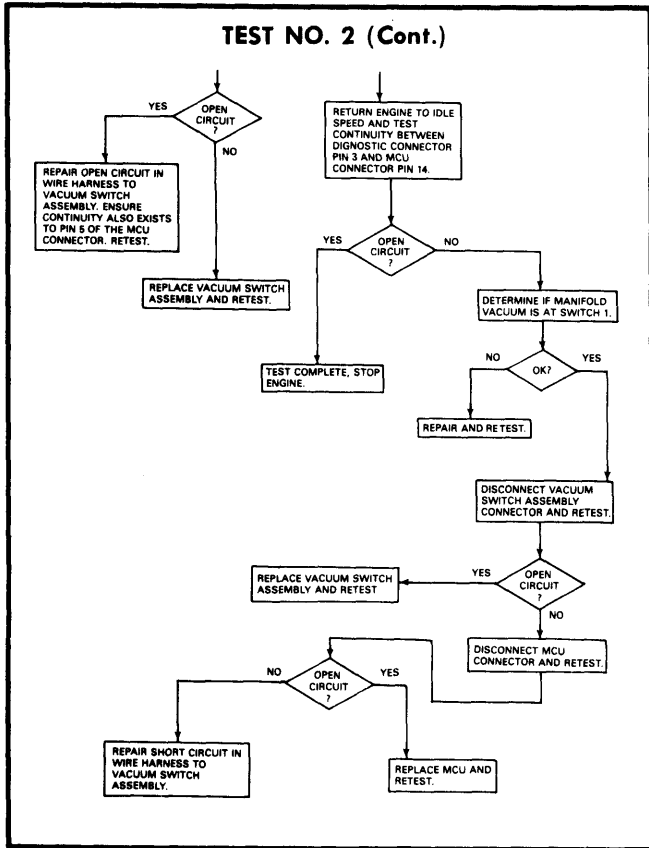

1982 Computerized Engine Controls 1a-25

AMERICAN MOTORS 6-CYL. COMPUTERIZED EMISSION CONTROL (Cont.)

TEST NO. 5

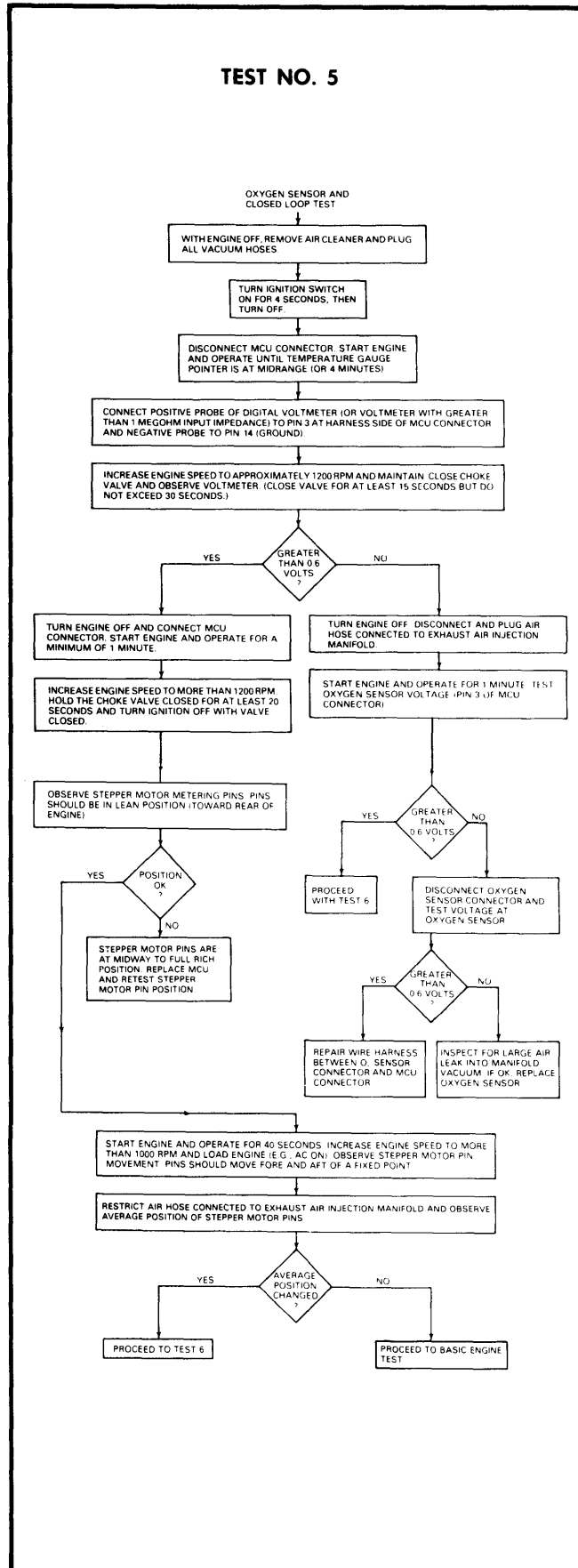

TEST NO. 6

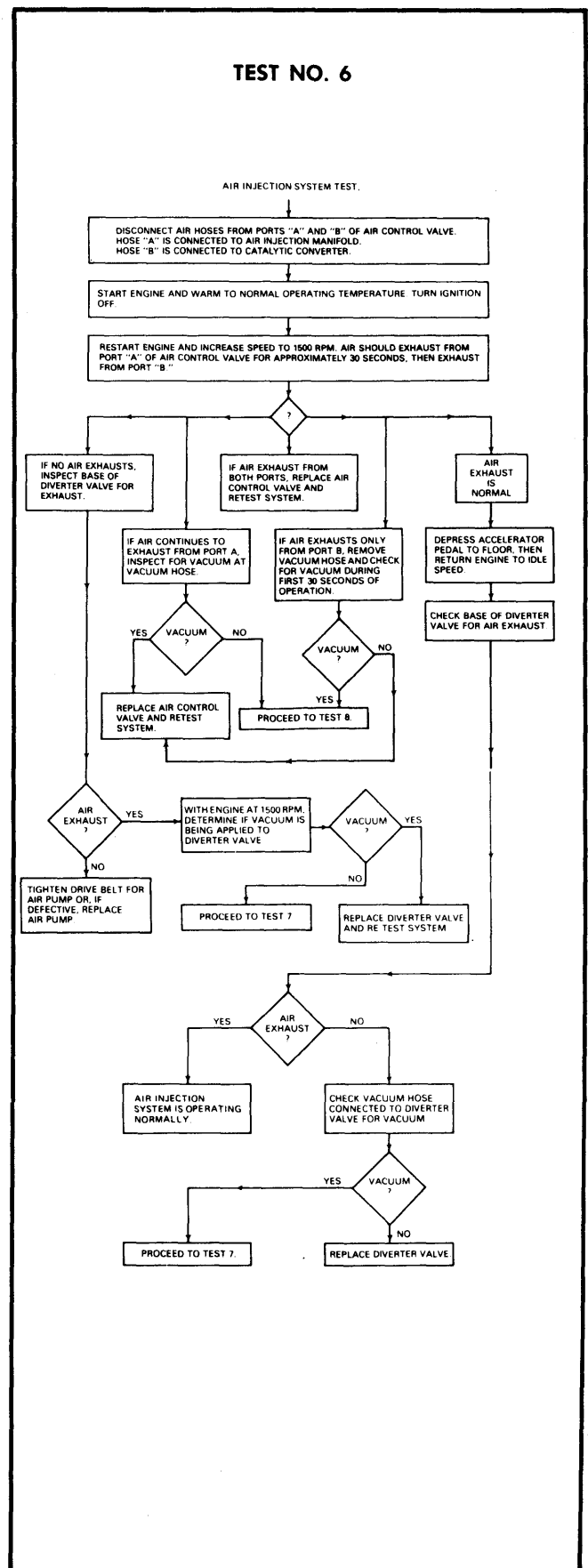

AMERICAN MOTORS 6-CYL. COMPUTERIZED EMISSION CONTROL (Cont.)

TEST NO. 7

NOTE: WHEN APPLICABLE, DIAGNOSTIC CONNECTOR TERMINALS CAN BE USED AS TEST POINTS INSTEAD OF MCU CONNECTOR TERMINALS.

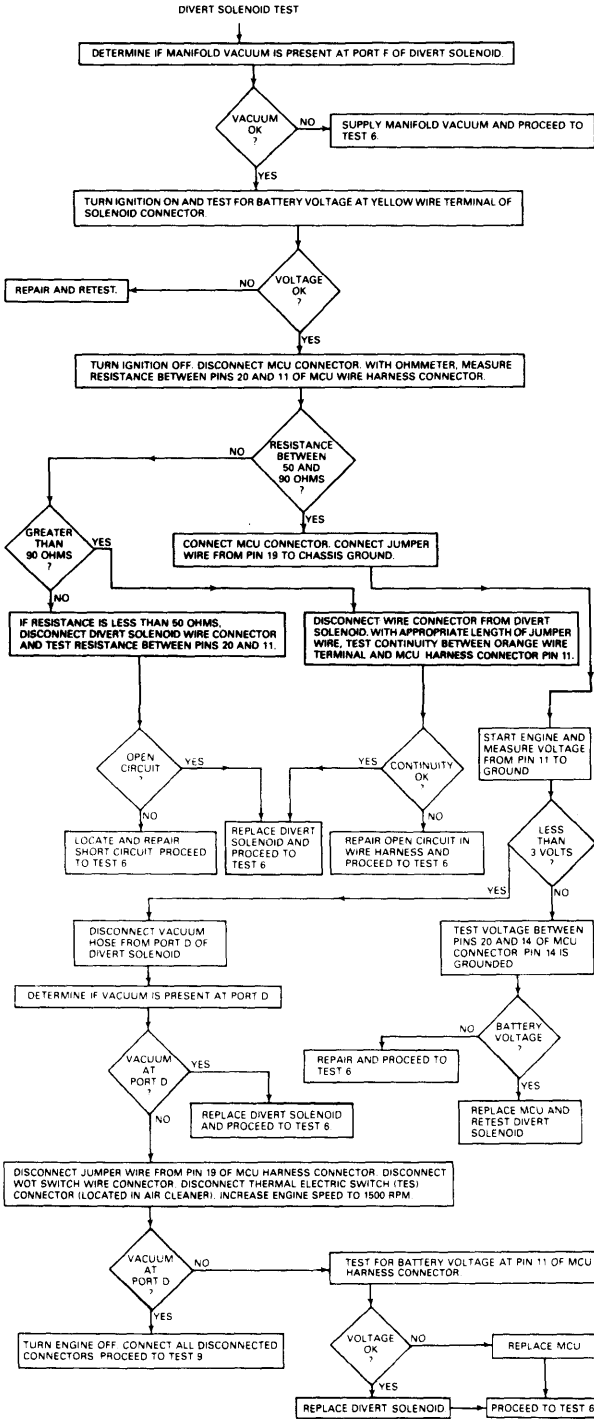

TEST NO. 8

NOTE: WHEN APPLICABLE, DIAGNOSTIC CONNECTOR TERMINALS CAN BE USED AS TEST POINTS INSTEAD OF MCU CONNECTOR TERMINALS.

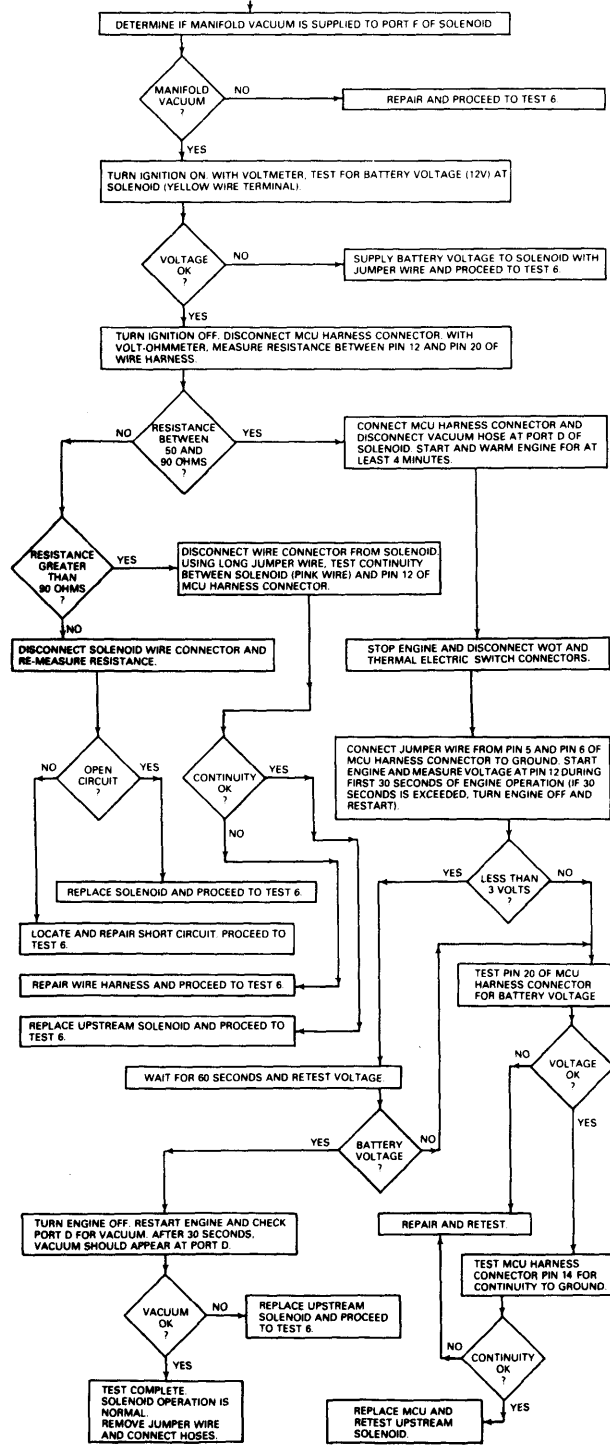

AMERICAN MOTORS 6-CYL. COMPUTERIZED EMISSION CONTROL (Cont.)

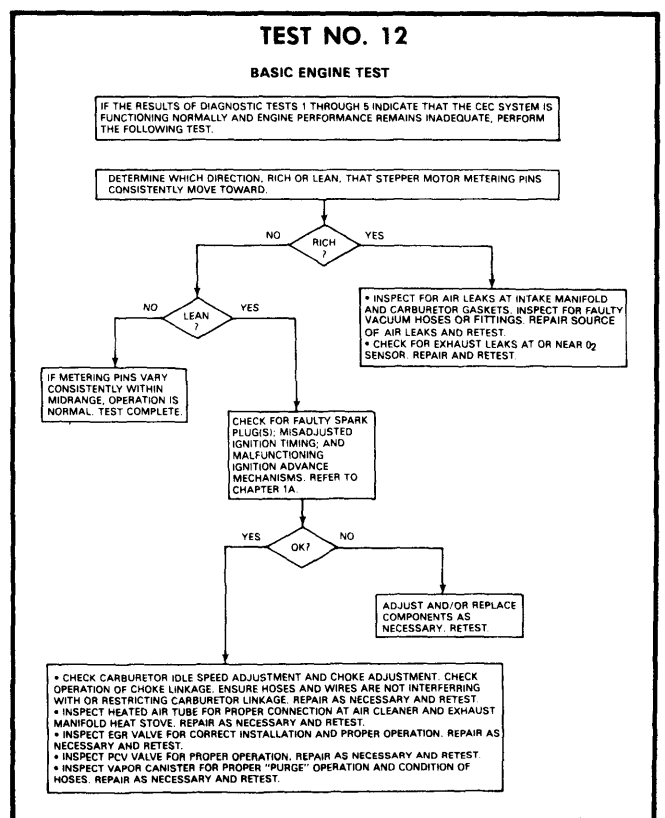
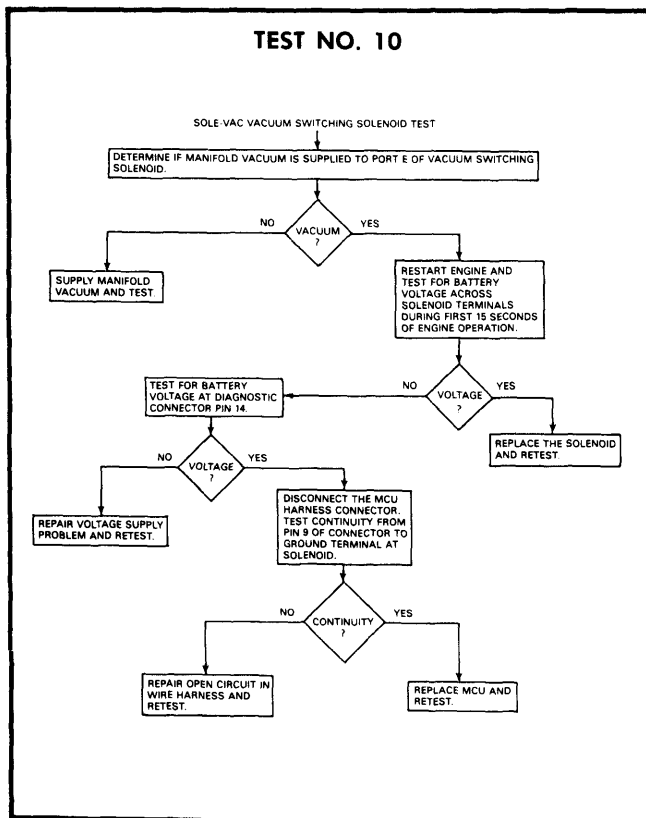
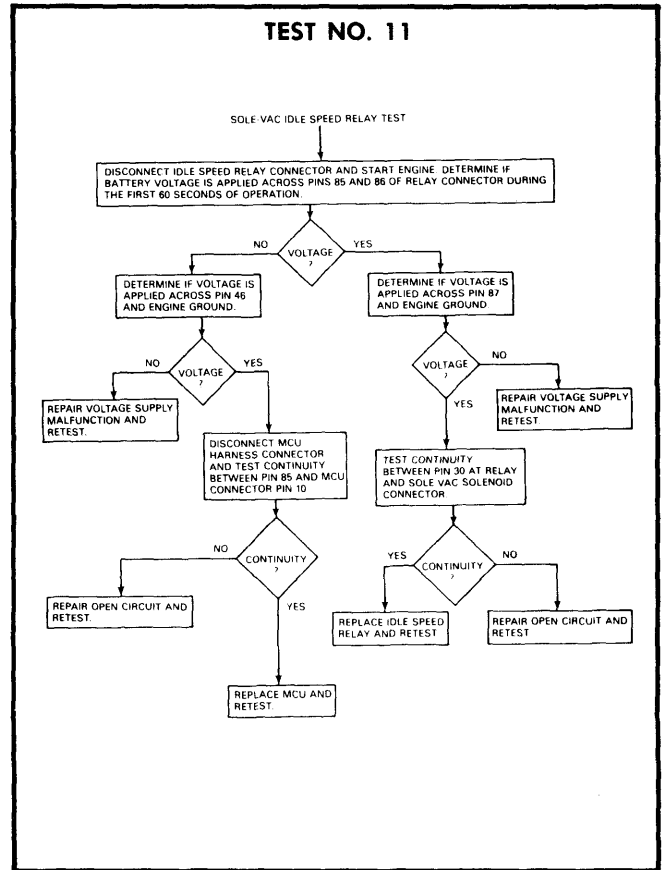
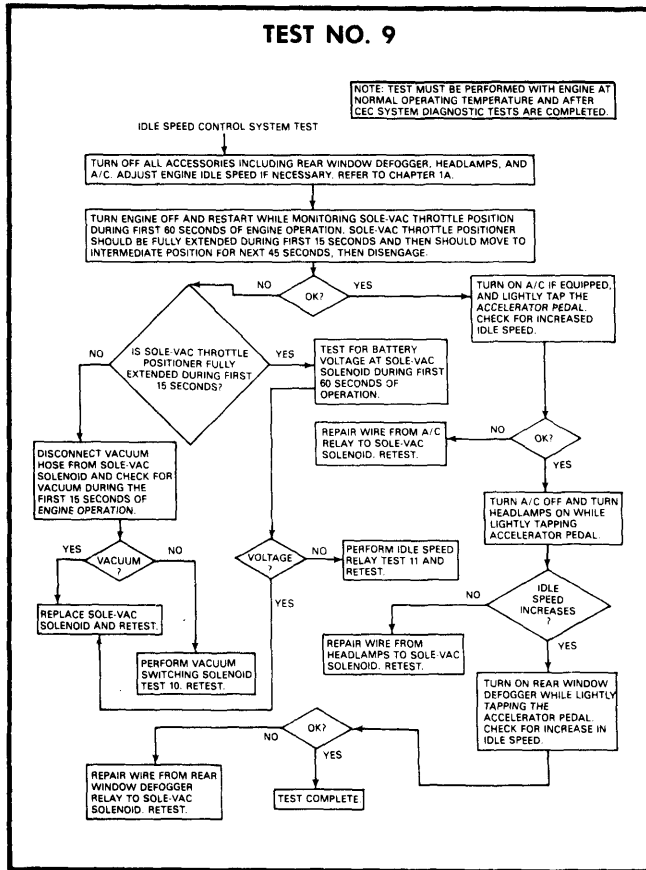

AMERICAN MOTORS 6-CYL. COMPUTERIZED EMISSION CONTROL (Cont.)

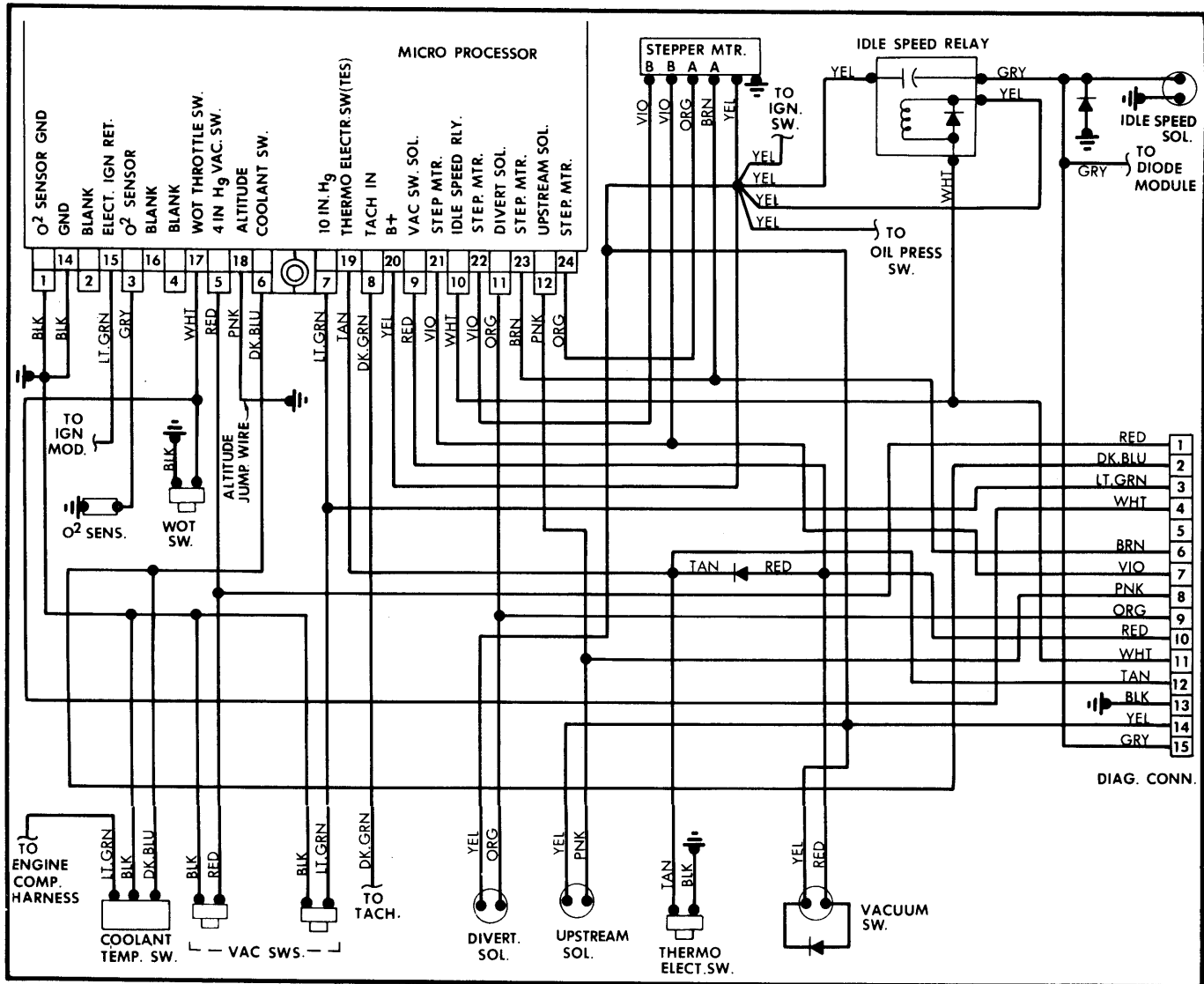

Fig. 3 American Motors 6-Cyl. CEC System Wiring Diagram

MAINTENANCE

The CEC system does not require periodic maintenance. However, when vehicle is raised for other services, check condition of catalytic converter, oxygen sensor and exhaust system.

REMOVAL & INSTALLATION

MICRO COMPUTER UNIT (MCU)

Removal & Installation — Remove MCU attaching bolts. Disconnect electrical plug connector. To install MCU, reverse removal procedure and ensure terminal ends are not forced out of position when connecting plug.

STEPPER MOTOR

CAUTION — Do not drop metering pins and spring when removing stepper motor.

Removal & Installation — Remove air cleaner and disconnect motor connector. Remove retaining screw and unit from carburetor. To install, reverse removal procedure and tighten screw to 25 INCH lbs. (2.8 N·m).

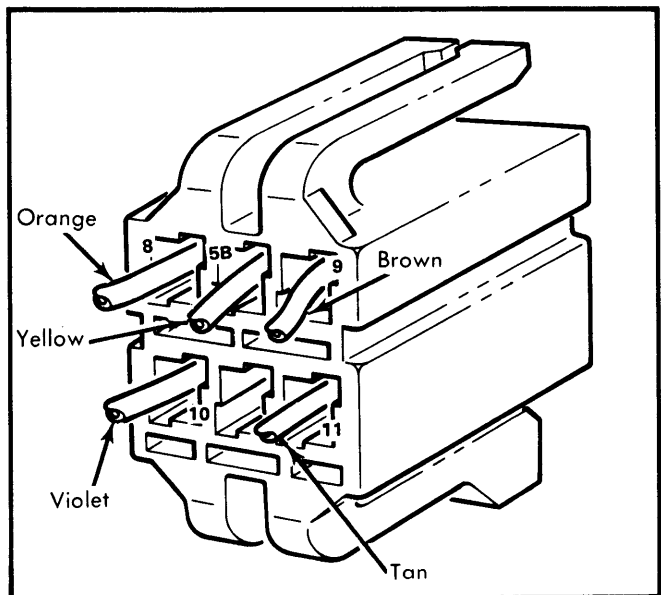

Fig. 4 Stepper Motor Connector Terminal Identification

AMERICAN MOTORS 6-CYL. COMPUTERIZED EMISSION CONTROL

COOLANT TEMPERATURE/INTAKE MANIFOLD HEATER COOLANT TEMPERATURE SWITCH

Removal & Installation — Disconnect electrical connector and remove switch. Install replacement switch and tighten to 72 INCH lbs. (8.1 N·m). Reconnect electrical lead.

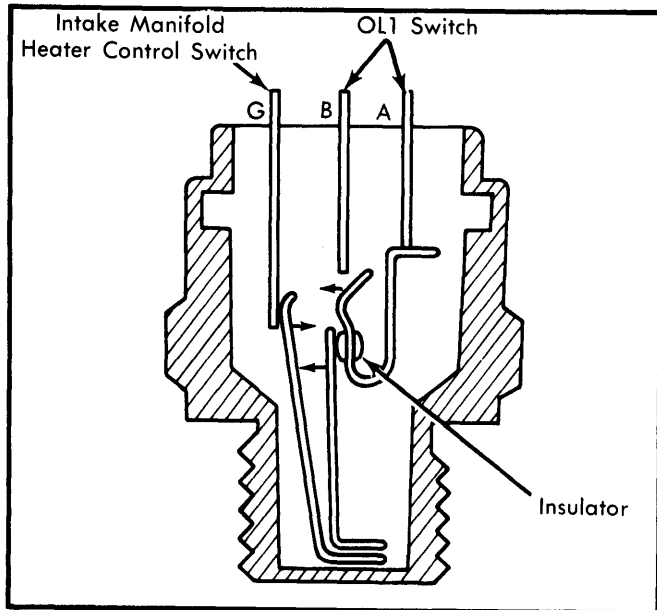

Fig. 5 Coolant Temperature Switch Schematic

VACUUM SWITCHES

Removal & Installation — Note positions of vacuum hoses and disconnect from switches. Disconnect electrical leads. Remove vacuum switches and bracket assembly. To install, reverse removal procedure.

NOTE — Vacuum switches are not serviced individually. Replace as component set.

OXYGEN SENSOR

Removal & Installation — Disconnect electrical lead and remove sensor from manifold. Clean threads of manifold. To install, coat threads of new oxygen sensor with anti-seize compound and carefully install sensor. Tighten sensor to 31 ft. lbs. (42 N·m). Reconnect electrical lead.

NOTE — Do not push rubber boot down on sensor body more than 1/2" above base. Also, oxygen sensor pigtail wires cannot be spliced or soldered. If broken, replace sensor.

TIMER

Removal & Installation — Disconnect electrical connector. Remove mounting screw and timer. To install, reverse removal procedure.