

MOTORCRAFT TFI IGNITION SYSTEM

Ford Motor Co.
Front Wheel Drive Models
with Auto. Trans.

DESCRIPTION

The TFI (Thick Film Integrated) ignition system is used on all front wheel drive vehicles equipped with an automatic transaxle. In the TFI ignition system, the small Blue plastic TFI ignition module replaces the bulky and much larger Dura-Spark module. The TFI Ignition module is mounted on the distributor housing and is attached with 2 retaining screws. It is electrically connected to the distributor's pick-up coil assembly without the use of a wiring harness between the ignition module and the pick-up coil assembly. Vehicles equipped with the TFI ignition system also use an E-Core ignition coil.

The TFI ignition system consists of a distributor, a TFI ignition module, E-Core ignition coil, ignition switch, battery, and primary and secondary wiring.

The distributor contains the following components: Pick-up coil assembly with internal teeth, distributor shaft, reluctor with external teeth (mounted on distributor shaft), TFI ignition module (mounted on outside of distributor housing), centrifugal and vacuum advance mechanisms, rotor and distributor cap (with male terminals).

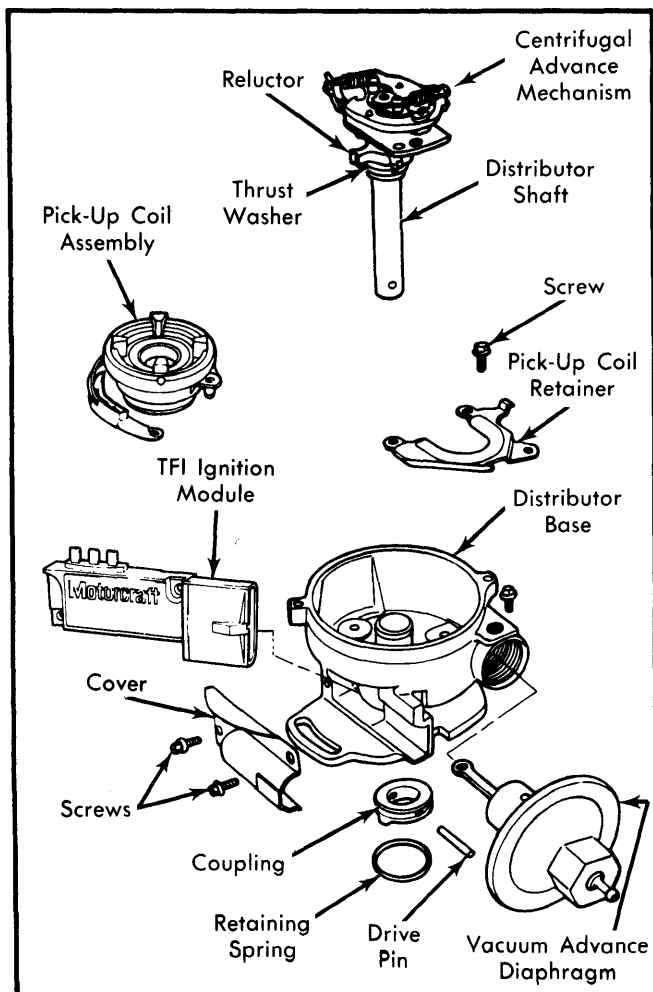

Fig. 1 Exploded View of TFI Distributor

The new E-Core ignition coil is unlike any previous Ford coil. It is encased in laminated plastic rather than being encased in an oil filled case, as most other coils are. This new ignition coil has a very low primary resistance and is used without a ballast resistor in the electrical system. There are the usual primary connections on this coil.

OPERATION

Each time the teeth on the reluctor pass the teeth on the pick-up coil, the magnetic field around the pick-up coil builds and collapses. As this occurs, a pulse is generated in the pick-up coil and sent to the TFI ignition module. The ignition module then turns the ignition coil's primary circuit off and on causing a high voltage surge in the secondary which fires the spark plugs.

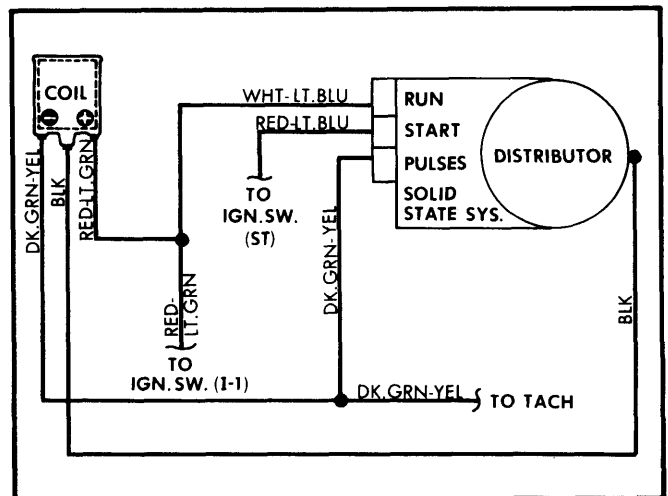

Fig. 2 TFI Ignition System Wiring Diagram

ADJUSTMENTS

No adjustments are to be made to the ignition system except initial engine timing and spark plug gap.

TESTING

NOTE — When a test requires the inspection of a wiring harness, both a visual inspection and a continuity test should be performed. When making measurements of a wire or connector, it is a good idea to wiggle the wires while measuring.

TEST SPARK PLUG

Use either a spark tester tool or modify a spark plug (cut off side terminal and install spring clip for grounding plug housing) for use in testing ignition system. See Fig. 3.

Distributors & Ignition Systems

MOTORCRAFT TFI IGNITION SYSTEM (Cont.)

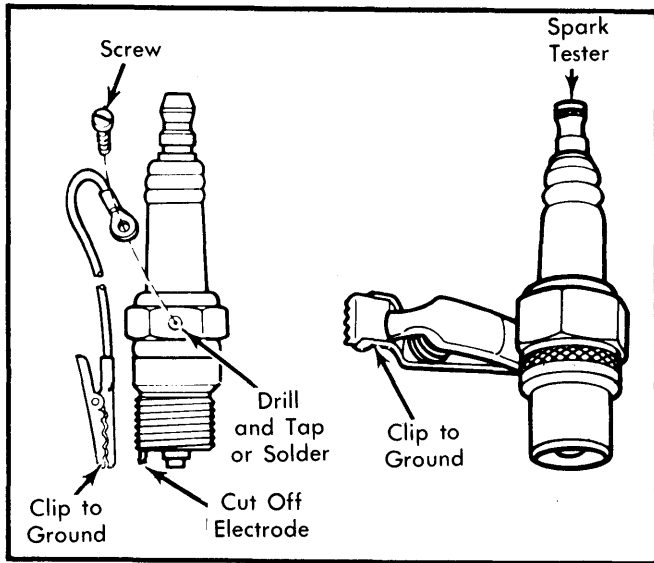

Fig. 3 Modified Spark Plug and Spark Tester

IGNITION COIL SECONDARY VOLTAGE CHECK

- 1) Disconnect ignition coil secondary wire from distributor cap and attach spark tester to wire. Crank engine. Disconnect spark tester and reconnect secondary wire to distributor cap.
- 2) If sparks occurred at tester gap, inspect distributor cap and rotor for damage, carbon tracking or lack of silicone compound. If no sparks occurred, measure resistance of ignition coil wire. Replace if greater than 5,000 ohms per inch. Proceed to "WIRING HARNESS CHECK".

IGNITION COIL PRIMARY CIRCUIT SWITCHING CHECK

- 1) Insert a small straight pin in wire to ignition coil negative terminal about 1" from ignition module connector. Attach test light between straight pin and engine ground. Crank engine. Remove test light and remove straight pin from wire. See Fig. 4.

NOTE — After test is completed, apply a small amount of silicone sealer to pin holes in wire.

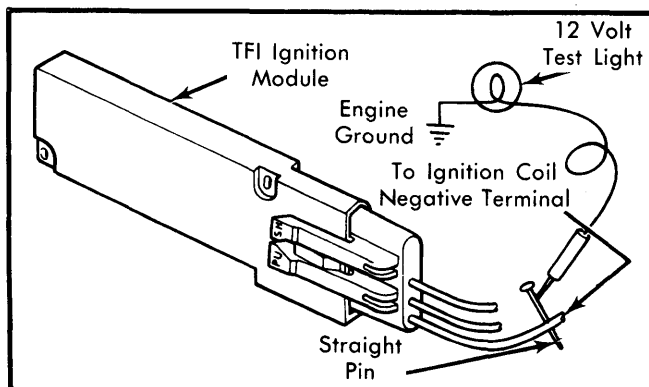

Fig. 4 Testing Ignition Coil Primary Circuit Switching

- 2) If test light flashes, proceed to "Ignition Coil Primary Resistance Check". If test light comes on but does not flash or if

test light does not come on at all, proceed to "Wiring Harness Check".

IGNITION COIL PRIMARY RESISTANCE CHECK

- 1) With ignition switch in "OFF" position, disconnect ignition coil connector. Connector ohmmeter leads to positive and negative terminals of ignition coil. Measure resistance.
- 2) If resistance was 0.3-1.0 ohms, proceed to "Ignition Coil Secondary Resistance Check". If resistance was less than 0.3 or greater than 1.0 ohms, replace ignition coil.

IGNITION COIL SECONDARY RESISTANCE CHECK

- 1) With ignition switch in "OFF" position, disconnect ignition coil connector and secondary wire. Connect ohmmeter leads to ignition coil's negative and secondary terminals. Measure resistance.
- 2) If resistance was 8,000-11,500 ohms, proceed to "Wiring Harness Check". If resistance was less than 8,000 or greater than 11,500 ohms, replace ignition coil.

WIRING HARNESS CHECK

- 1) Disconnect ignition module connector from ignition module. Disconnect wire at "S" terminal of starter relay. Attach negative lead of voltmeter to distributor base and measure battery voltage at battery. With negative lead of voltmeter still connected to distributor base, check voltage in each of the following situations:

- Positive voltmeter lead connected to terminal No. 1 of ignition module connector with ignition switch in the "RUN" position. See Fig. 5.
- Positive voltmeter lead connected to terminal No. 2 of ignition module connector with ignition switch in the "RUN" position. See Fig. 5.
- Positive voltmeter lead connected to terminal No. 3 of ignition module connector with ignition switch in the "START" position. See Fig. 5.

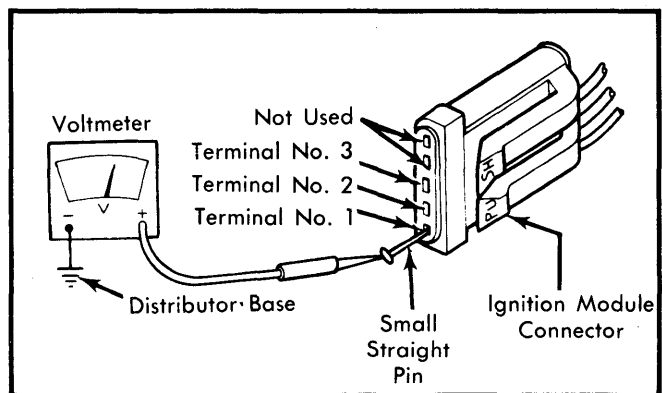

Fig. 5 Test Points for Wiring Harness Check

- 2) If reading was at least 90 percent of battery voltage, proceed to "Pick-Up Coil and Ignition Module Check". If reading was less than 90 percent of battery voltage, inspect for wiring harness problems or a worn or damaged ignition switch.

MOTORCRAFT TFI IGNITION SYSTEM (Cont.)

PICK-UP COIL AND IGNITION MODULE CHECK

1) Remove distributor from engine and remove ignition module from distributor housing. Inspect distributor ground screw, pick-up coil assembly wires and terminals. Measure pick-up coil resistance with ohmmeter leads connected to points shown in Fig. 6.

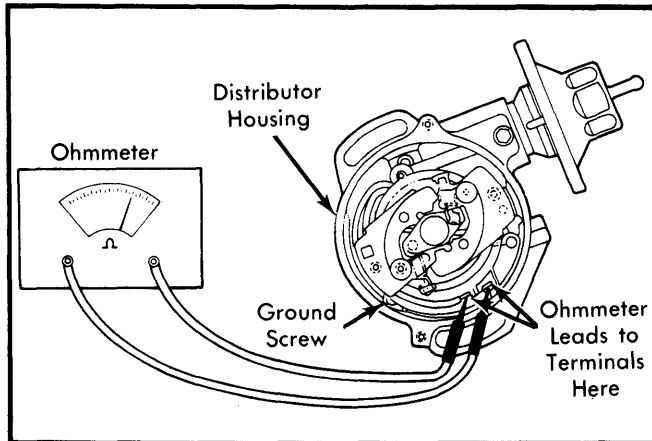

Fig. 6 Pick-Up Coil Assembly Resistance Test Points

2) If resistance was 650-1300 ohms, pick-up coil assembly is OK, replace ignition module. If resistance was less than 650 or greater than 1300 ohms, ignition module is OK, replace pick-up coil assembly. Reinstall ignition module on distributor housing and install distributor on engine.

IGNITION COIL PRIMARY VOLTAGE CHECK

1) Attach negative lead of voltmeter to distributor base and measure battery voltage. Turn ignition switch to "RUN" position. Connect positive lead of voltmeter to coil connector negative terminal (connector still connected to coil). Measure voltage. Turn ignition switch to "OFF" position.

2) If reading was at least 90 percent of battery voltage, inspect wiring harness between ignition module and ignition coil negative terminal. If reading was less than 90 percent of battery voltage, inspect wiring harness between ignition module and ignition coil negative terminal and proceed to "Ignition Coil Voltage Supply Check".

IGNITION COIL VOLTAGE SUPPLY CHECK

1) Attach negative lead of voltmeter to distributor base. Measure battery voltage. Turn ignition switch to "RUN" position. Connect positive voltmeter lead to positive terminal of ignition coil connector (connector still connected to ignition coil). Read voltmeter and turn ignition switch "OFF".

2) If reading was at least 90 percent of battery voltage, inspect ignition coil and ignition coil connector for dirt, corrosion or damage. Replace ignition coil if necessary. If reading was less than 90 percent of battery voltage, repair wiring between ignition coil and ignition switch. Also check for a worn or damaged ignition switch.

OVERHAUL

NOTE — Except for the additional step of removing the TFI ignition module, disassembly and reassembly procedures are the same as for the Dura-Spark II distributor (used in front wheel drive models with manual transmissions). Removal procedures for the TFI ignition module are given below. For complete distributor overhaul procedures, see Dura-Spark II article in this section.

TFI IGNITION MODULE

Removal — 1) Disconnect wiring harness connector from ignition module. Remove distributor cap, with secondary wiring connected, and position out of way. Remove distributor hold down bolt and remove distributor from engine.

2) With distributor on work bench, remove the 2 ignition module retaining screws. Pull the right side of the ignition module down to the distributor mounting flange. Push ignition module back up and ignition module terminals will disengage from connector in distributor. Pull ignition module down and away from distributor to remove.

Installation — Reverse removal procedures and note the following: Coat the metal base plate of ignition module with about $\frac{1}{32}$ " of silicone grease before installing. Be sure that ignition module terminals are fully engaged in distributor connector. Tighten the 2 ignition module retaining screws to 9-16 INCH Lbs. (1.1-1.8 N·m).