

## MOTORCRAFT DURA-SPARK III IGNITION SYSTEM (EEC)

Ford Motor Co.  
5.0L V8 With EFI

### DESCRIPTION

The ignition portion of the EEC III system is referred to as Dura-Spark III, a solid state system which provides power switching of the ignition coil. Dura-Spark III input signals are controlled by the EEC system.

The EEC distributor, unlike Dura-Spark II, has no centrifugal or vacuum advance. Also, it has no armature (reluctor) or stator (pick-up coil). See Fig. 1. Secondary wires and spark plugs are the same, however, as used in Dura-Spark II systems.

Although control modules appear similar, they must not be interchanged. Dura-Spark III control modules have no purple wire and can also be identified by a brown grommet (Dura-Spark II modules have a blue grommet).

Ignition timing is determined by the crankshaft position (CP) sensor and 6 or 7 other engine sensors. These sensors feed information to the EEC III system Electronic Control Assembly (ECA) through a special 32-pin connector. For further information on these sensors and the electronic control assembly, see *Ford Motor Co. Electronic Engine Control III* article in **COMPUTERIZED ENGINE CONTROLS SECTION**.

Unlike conventional distributors that are restricted to approximately 20° advance, the EEC system permits up to 50° distributor advance. Both distributor cap and rotor have upper and lower electrode levels. As the rotor turns, one of the high voltage electrode pick-up arms is aligned with one arm of the distributor cap center electrode plate. This allows high voltage to pass from the center plate arms through the rotor, distributor cap, and spark plug wire to the appropriate spark plug.

### OPERATION

With the ignition switch turned on, the primary circuit is on and the ignition coil is energized. See Fig. 2. The EEC system (not

the distributor as in Dura-Spark II systems) provides a signal telling the ignition module to turn off the coil primary circuit.

The length of time the primary circuit is turned on or off is controlled by the EEC Electronic Control Assembly (ECA). See Fig. 3. When the current is on, it flows from the battery through the ignition switch, primary windings of ignition coil, and ignition module circuits to ground.

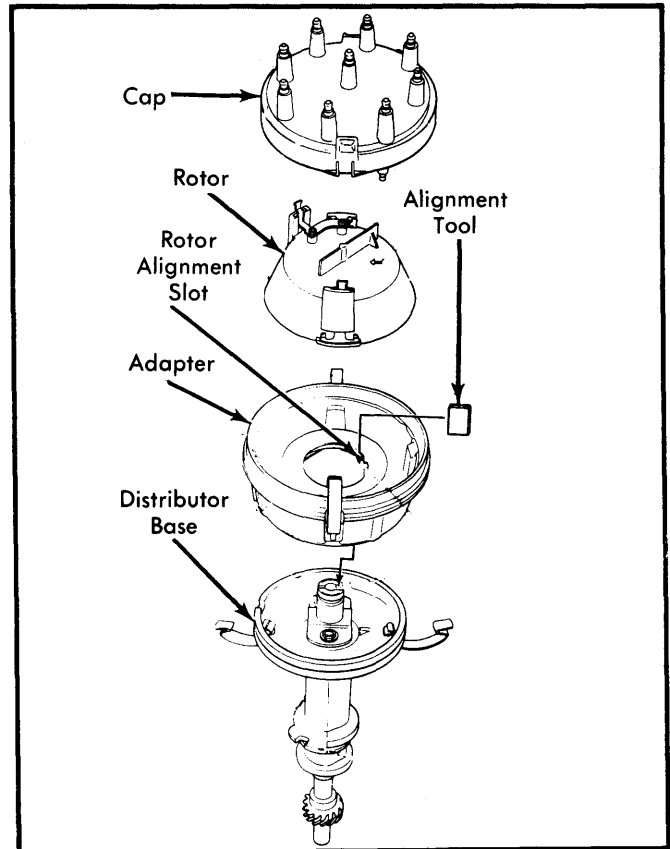

Fig. 1 Exploded View of Dura-Spark III Distributor

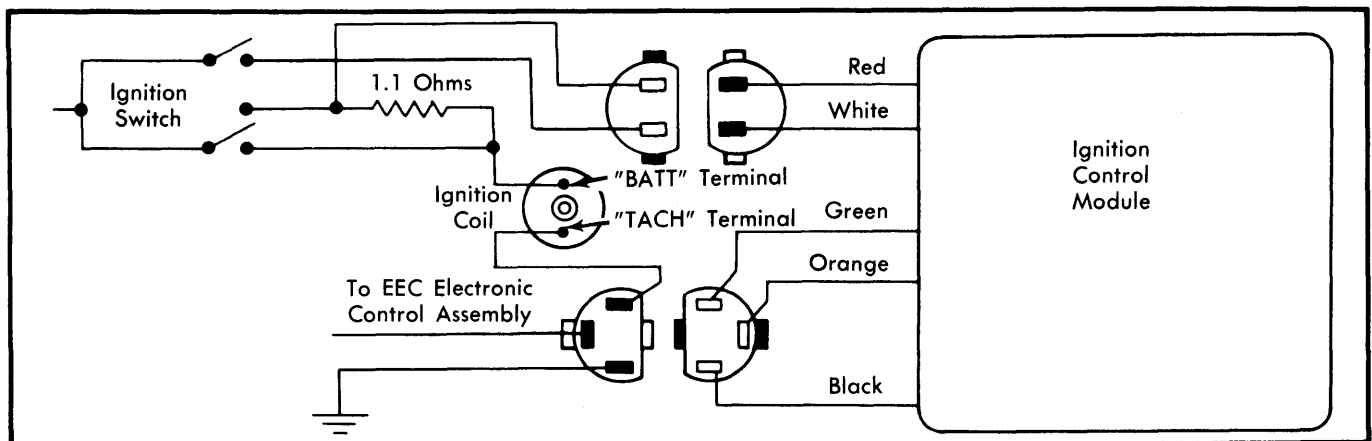
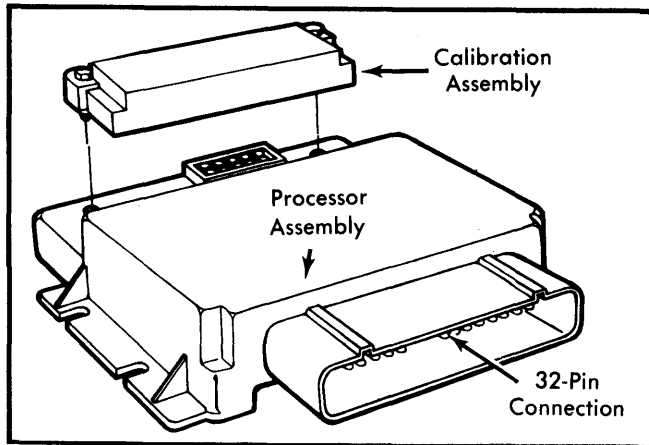

Fig. 2 Wiring Schematic of Dura-Spark III Ignition System

# Distributors & Ignition Systems

## MOTORCRAFT DURA-SPARK III IGNITION SYSTEM (EEC) (Cont.)



**Fig. 3 EEC III Electronic Control Assembly. Located on Left Front Inner Fender Well**

When current is turned off, the magnetic field which is built up in the ignition coil collapses, inducing high voltage to the secondary windings of the coil. This high voltage, produced each time the magnetic field builds and collapses, is transmitted by the coil to the distributor cap, rotor and to individual spark plugs.

### TESTING

**NOTE** — Before beginning test procedures, visually inspect the engine compartment to ensure all vacuum hoses and spark plug wires are properly routed and connected. Check all wiring harnesses and connectors for damage. Be sure that battery is fully charged. All wire colors referred to are colors of ignition module wires. When test requires inspection of wiring harness, both visual and continuity checks should be performed. Also, when making measurements on a wiring harness or connector, wiggle the wires while measuring.

### SPARK TESTER

Use either a spark tester tool or modify a spark plug (cut off side terminal and install spring clip for grounding plug housing) for use in testing ignition system. See Fig. 4.

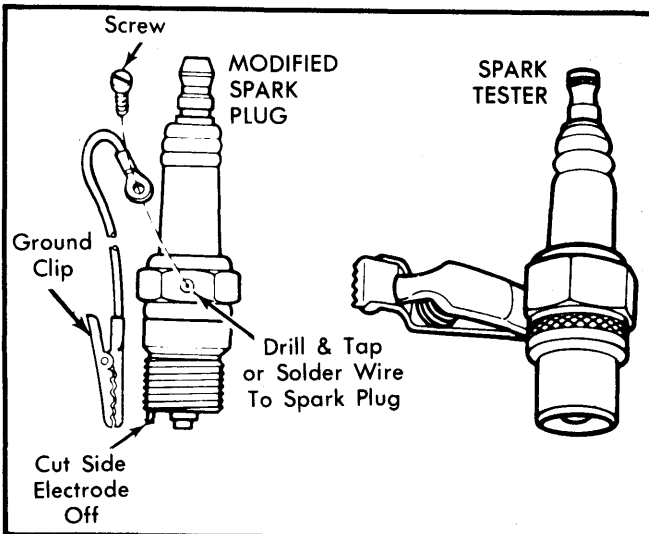

**Fig. 4 Modified Spark Plug & Spark Tester. Spark Plug Modified by Cutting Off Side Terminal and Installing Spring Clip**

### RUN CIRCUITS CHECK

1) Disconnect ignition module 3-wire connector and install ignition diagnostic test adapter (T79P-12127-A or equivalent) as shown in Fig. 5. Disconnect ignition coil wire from distributor and connect spark tester to wire and engine ground.

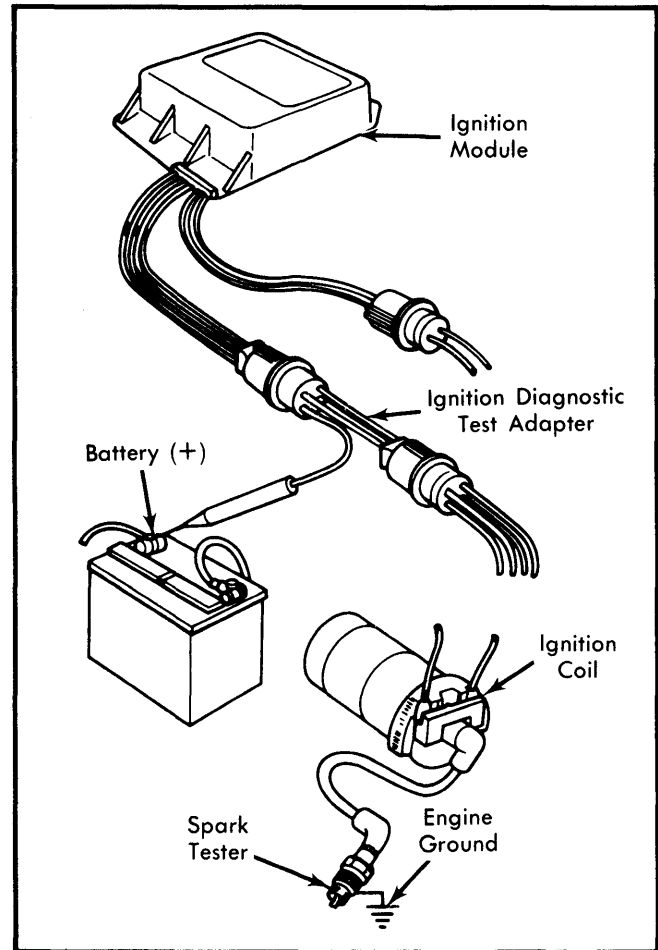

**Fig. 5 Ignition Diagnostic Test Adapter and Spark Tester Hook-Up for Run Circuits Check**

2) Turn ignition switch to "RUN" position and touch diagnostic adapter lead to positive battery terminal. Sparks should occur at tester gap each time lead touches battery terminal. Turn ignition switch to "OFF" position, remove spark tester and remove ignition diagnostic test adapter. Reconnect all wires.

3) If sparks occurred at tester gap, proceed to "Start Circuits Check". If no sparks occurred at tester gap, proceed to "Ignition Coil Primary Circuit Switching Check".

### START CIRCUITS CHECK

1) Disconnect ignition coil wire from distributor cap and attach spark tester to wire and engine ground. Crank engine using ignition switch. Disconnect spark tester and reconnect coil wire to distributor.

2) If spark occurred at tester gap, inspect distributor cap, adapter and rotor for cracks, carbon tracking or lack of silicone compound. If sparks did not occur at tester gap, proceed to "Voltage Supply Circuits Check".

## MOTORCRAFT DURA-SPARK III IGNITION SYSTEM (EEC) (Cont.)

### IGNITION COIL PRIMARY CIRCUIT SWITCHING CHECK

1) Disconnect ignition module 3-wire connector and install diagnostic adapter (T79P-12127-A or equivalent). Connect a test light between "TACH" terminal of ignition coil and an engine ground. With ignition switch in "RUN" position, touch diagnostic adapter test lead to positive battery terminal.

2) Test light should flash each time test lead is either connected to or removed from battery terminal. Turn ignition switch to "OFF" position, remove diagnostic adapter, and reconnect ignition module wires. If test light flashes, proceed to "Ignition Coil Secondary Resistance Check". If test light does not flash or is dim, proceed to "Voltage Supply Circuits Check".

### IGNITION COIL SECONDARY RESISTANCE CHECK

1) Disconnect ignition coil connector and secondary wire from ignition coil. Connect ohmmeter leads to "TACH" and high voltage terminals of ignition coil. Measure resistance, remove ohmmeter leads, and connect disconnected wires.

2) If resistance was 7,700-10,500 ohms, coil is OK, measure resistance of ignition coil wire. If wire resistance is greater than 5,000 ohms per inch, replace ignition coil wire and proceed to "Ignition Coil Primary Resistance Check". If coil resistance is less than 7,700 or greater than 10,500 ohms, replace ignition coil.

### VOLTAGE SUPPLY CIRCUITS CHECK

1) If starter relay has an "I" terminal, disconnect cable from starter relay to starter motor. If starter relay does not have an "I" terminal, disconnect wire to "S" terminal of starter relay. Carefully insert small straight pins in Red and White ignition module wires. See Fig. 6.

**CAUTION** — Do not allow straight pins to contact an electrical ground.

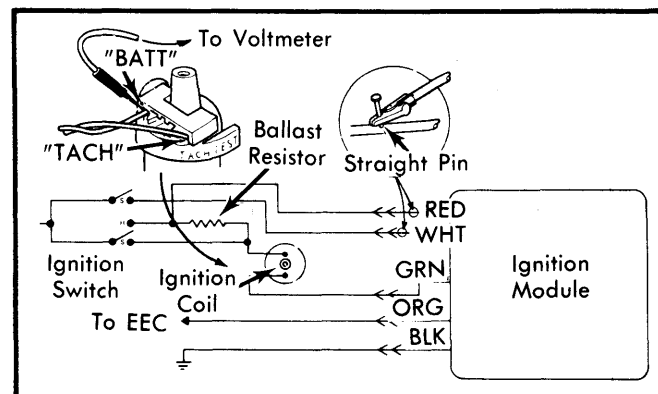

**Fig. 6** Installing Straight Pins in Red & White Control Module Wires for Voltage Supply Circuits Check

2) Measure battery voltage at battery. Measure voltage in each of the following situations at points indicated:

- With ignition switch in "RUN" position, connect negative lead of voltmeter to an engine ground and positive lead of voltmeter to straight pin in Red wire.

- With ignition switch in "START" position, connect negative lead of voltmeter to an engine ground and positive lead of voltmeter to straight pin in White wire.

- With ignition switch in "START" position, connect negative lead of voltmeter to an engine ground and positive lead of voltmeter to ignition coil "TACH" terminal.

3) Turn ignition switch "OFF", remove ohmmeter and straight pins, and reconnect starter relay cables. If voltage was at least 90 percent of battery voltage, proceed to "Ignition Coil Voltage Supply Check". If voltage was less than 90 percent of battery voltage, inspect wiring harness and connectors. Also check for a worn or damaged ignition switch.

### IGNITION COIL VOLTAGE SUPPLY CHECK

1) Attach negative lead of voltmeter to engine ground and positive lead of voltmeter to "BATT" terminal of ignition coil. Turn ignition switch to "RUN" position and measure voltage. Turn ignition switch to "OFF" position.

2) If voltage was 6-8 volts, proceed to "Module-to-Coil Wire Resistance Check". If voltage was less than 6 volts or greater than 8 volts, proceed to "Ignition Coil Primary Resistance Check".

### MODULE-TO-COIL WIRE RESISTANCE CHECK

1) Disconnect ignition coil connector from ignition coil and disconnect ignition module 3-wire connector. Connect ohmmeter leads to engine ground and "TACH" terminal of ignition coil connector. Measure resistance. Remove ohmmeter leads and reconnect ignition module and coil connectors.

2) If resistance was greater than 1 ohm, replace ignition module. If resistance was 1 ohm or less, inspect wiring harness between ignition module and ignition coil.

### IGNITION COIL PRIMARY RESISTANCE CHECK

1) Disconnect ignition coil connector. Connect ohmmeter leads to "BATT" and "TACH" terminals of ignition coil. Measure resistance, remove ohmmeter leads, and reconnect ignition coil connector.

2) If resistance was 9.8-1.6 ohms, proceed to "Module-to-Coil Wire Voltage Check". If resistance was less than 0.8 ohms or greater than 1.6 ohms replace ignition coil.

### MODULE-TO-COIL WIRE VOLTAGE CHECK

1) Carefully insert a small straight pin in Green ignition module wire. Turn ignition switch to "RUN" position. Attach negative lead of voltmeter to engine ground and positive lead to straight pin in Green wire then to "TACH" terminal of ignition coil, reading voltage at both points. Turn ignition switch to "OFF" position.

2) If the difference in voltage readings was less than 0.5 volts, proceed to "Primary Circuit Continuity Check". If difference in voltage readings was greater than 0.5 volts, inspect wiring harness between ignition module and ignition coil.

### PRIMARY CIRCUIT CONTINUITY CHECK

1) Carefully insert a small straight pin in Green ignition module wire. Connect negative voltmeter lead to engine

# Distributors & Ignition Systems

## MOTORCRAFT DURA-SPARK III IGNITION SYSTEM (EEC) (Cont.)

ground and positive voltmeter lead to pin in Green wire. Turn ignition switch to "RUN" position and measure voltage. Turn ignition switch to "OFF" position, remove voltmeter, and remove straight pin.

2) If voltage was greater than 1.5 volts, proceed to "Ground Circuit Continuity Check". If voltage was 1.5 volts or less, proceed to "Ballast Resistor Check".

### BALLAST RESISTOR CHECK

1) Disconnect ignition module 2-wire connector. Disconnect ignition coil connector from ignition coil. Connect ohmmeter leads to "BATT" terminal of ignition coil connector and to wiring harness terminal that mates with Red module wire. Measure resistance. Reconnect ignition coil and ignition module connectors.

2) If resistance was 0.8-1.6 ohms, replace ignition module. If resistance was less than 0.8 ohms or greater than 1.6 ohms, replace ballast resistor.

### GROUND CIRCUIT CONTINUITY CHECK

1) Carefully insert a small straight pin in ignition module Black wire. Attach negative voltmeter lead to ground. Attach positive voltmeter lead to straight pin in Black wire. Turn ignition switch to "RUN" position and measure voltage. Turn ignition switch to "OFF" position and remove straight pin.

2) If voltage was greater than 0.5 volts, proceed to "Wiring Harness Ground Circuit Check". If voltage was less than 0.5 volts, replace ignition module.

### WIRING HARNESS GROUND CIRCUIT CHECK

1) Disconnect ignition module 3-wire connector. Connect ohmmeter leads to engine ground and terminal in wiring harness connector that mates with Black wire of ignition module. Measure resistance. Reconnect ignition module 3-wire connector.

2) If resistance was less than 1 ohm, inspect Black wire, ignition module connector, and wiring harness connector. If resistance was greater than 1 ohm, replace ignition module.

### SPARK PLUG WIRE CHECK

1) Disconnect spark plug end of suspected wire or wires. Remove distributor cap. Measure resistance of spark plug

wires by touching ohmmeter probes to each end of wire. Measure from inside distributor cap. If resistance is less than 5,000 ohms per inch, wire is OK.

2) If resistance is more than 5,000 ohms per inch, remove wire from cap and measure resistance of wire only. If it is less than 5,000 ohms, wire is OK. Check distributor cap and spark plug terminal for corrosion. Also check spark plug. If more than 5,000 ohms, replace spark plug wire.

## OVERHAUL

### ROTOR

**Removal** — Remove distributor cap. Remove rotor by pulling up on rotor pull tab. Rotor is held in place by a spring clip.

**NOTE** — Rotor removal is only necessary when replacing rotor or adapter or when checking rotor condition. No adjustment to distributor is needed when rotor is replaced.

**Installation** — 1) Coat rotor lower electrode blade only (not upper blades) using silicone grease. Coat all 4 distributor cap center blade arms to a  $\frac{1}{32}$ " thickness.

2) To check rotor alignment, set No. 1 piston on compression stroke. Rotate crankshaft until rotor alignment tool (T79P-12200-A) can be inserted into alignment slots in rotor and center of shaft. See Fig. 7.

3) Read timing mark on damper that is aligned with pointer. If timing mark is within  $4^\circ$  of specification, do not reset rotor alignment. EEC models with feedback carburetors should be adjusted to TDC; those with EFI to  $5^\circ$  ATDC. Either adjustment may be  $\pm 4^\circ$ .

4) If alignment is not within  $4^\circ$  of specified timing when installing rotor, remove alignment tool, position crankshaft at proper timing mark and loosen 2 sleeve assembly adjustment screws. Rotate sleeve until alignment tool fits into alignment slots. Tighten adjustment screws and remove alignment tool.

5) Align arrow, molded into top of rotor, with large key way slot in distributor sleeve. Press down on rotor until retaining spring snaps into place.

**NOTE** — Since EEC distributors have no vacuum or centrifugal advance mechanisms, overhaul is limited to removal, inspection and alignment of rotor or removal and inspection of cap.

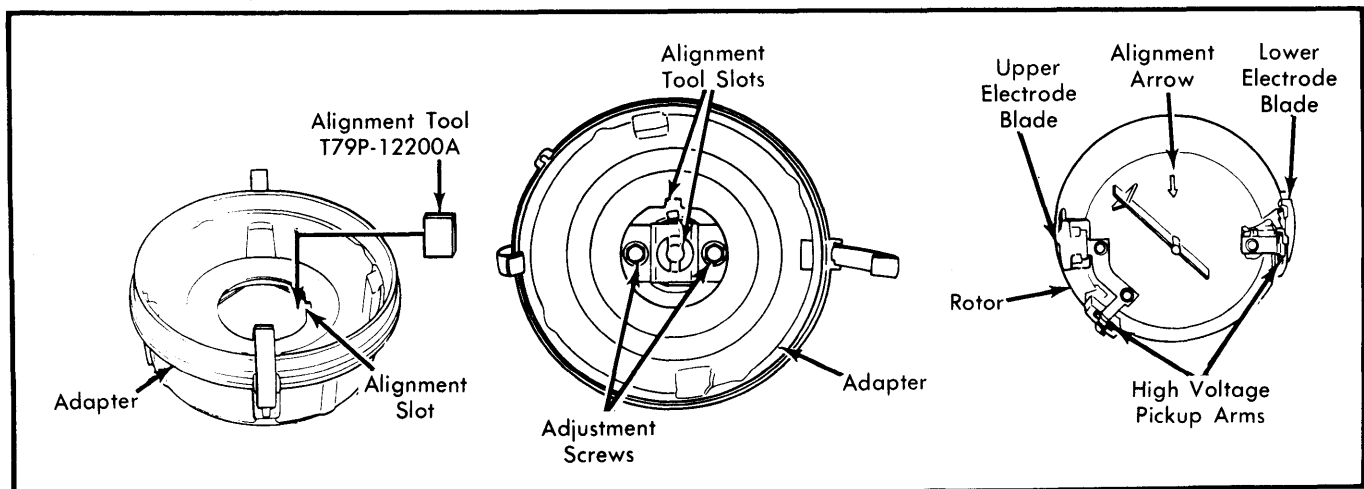

Fig. 7 Rotor and Adapter for Dura-Spark III Distributor Showing Rotor and Adapter-to-Distributor Shaft Alignment