

## CHRYSLER CORP. AIR INJECTION SYSTEMS

## DESCRIPTION

The Air Injection System adds a controlled amount of fresh air to the exhaust gases at the exhaust manifold or downstream to aid in complete oxidation of the gases. This results in reduced levels of carbon monoxide and hydrocarbon emissions. The 2.6L engine uses a Pulse Air Feeder (PAF) system to supply this additional air, while all other engines use an air pump air injection system. The Pulse Air Feeder system consists of a main-reed valve and a sub-reed valve within the pulse air feeder to control air flow. Air pump injection systems consist of a belt driven air pump, a combination diverter-pressure relief valve, a switching valve, hoses and check valves to protect the hoses and other components from hot gases, and injection tubes.

## OPERATION

## PULSE AIR FEEDER

The main-reed valve responds to pressure fluctuations generated within the No. 3 cylinder crankcase, since the crankcase is sealed by a seal cover. This cover has a small hole for discharging engine oil and any blow by. The sub-reed valve is actuated by exhaust vacuum generated from pulsation in the exhaust system between the front and rear catalytic converters.

## AIR PUMP

The belt driven pump is mounted at the front of the engine with power take off from the crankshaft pulley on all except the 2.2L engine. The air pump on the 2.2L engine is mounted at the rear of the engine and is driven by the camshaft pulley. On 1.7L engines, intake air enters the air pump through a tube at the rear of the pump. On all other pumps, intake air enters through a centrifugal filter fan on the front of the pump.

**CAUTION** — The intake tube at the rear of pumps used on 1.7L engines is larger in diameter than the discharge tube. If hoses are not connected properly, pump may be damaged.

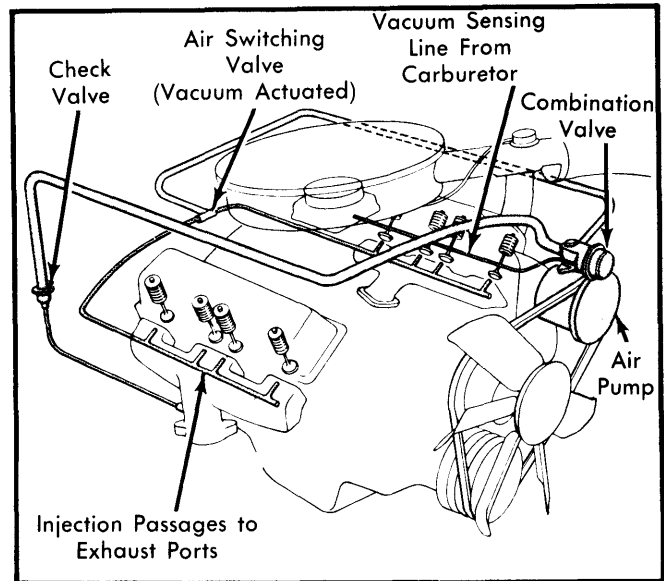

Fig. 2 Air Pump Injection System (8-Cyl. Engine Shown)

## AIR SWITCHING VALVE

This valve directs air injection flow to either the location near the exhaust ports or to the downstream injection point. It also serves as a relief valve at high engine speeds.

A vacuum signal from either a coolant control engine vacuum switch (CCEVS) or vacuum solenoid causes the switching valve to open, allowing air pump air to flow to the exhaust ports. When CCEVS shuts off vacuum signal to switching valve, a bleed orifice in vacuum line of combination valve allows vacuum to go to zero, causing valve to switch air pump air to injection point downstream.

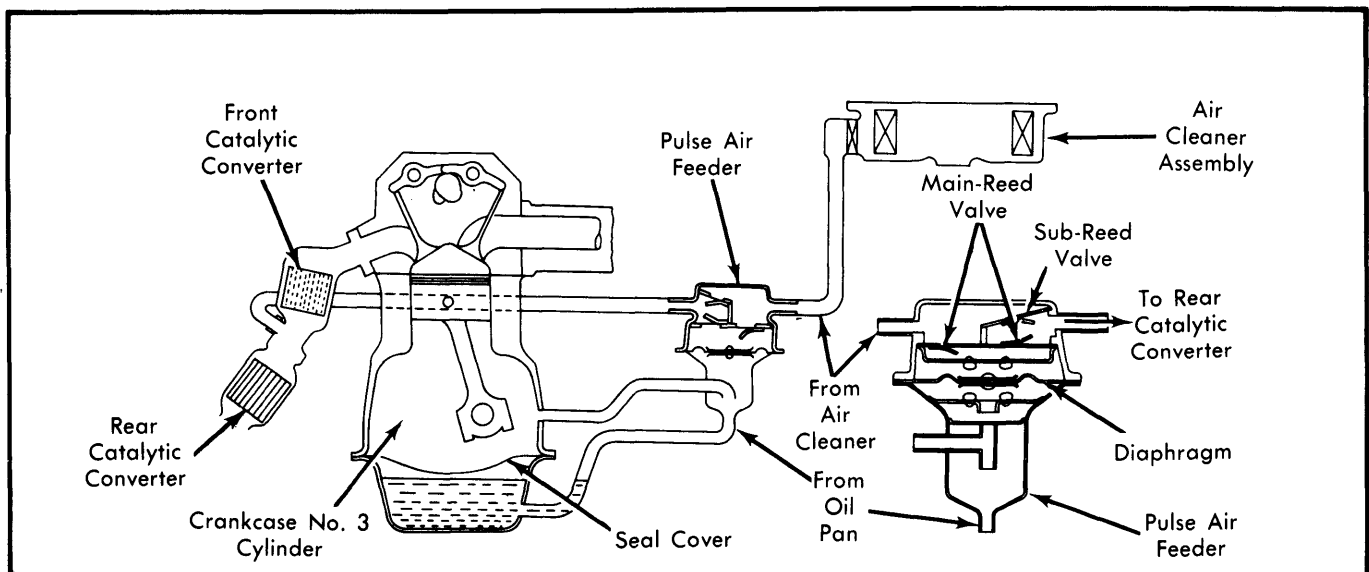

Fig. 1 Pulse Air Feeder System

## CHRYSLER CORP. AIR INJECTION SYSTEMS (Cont.)

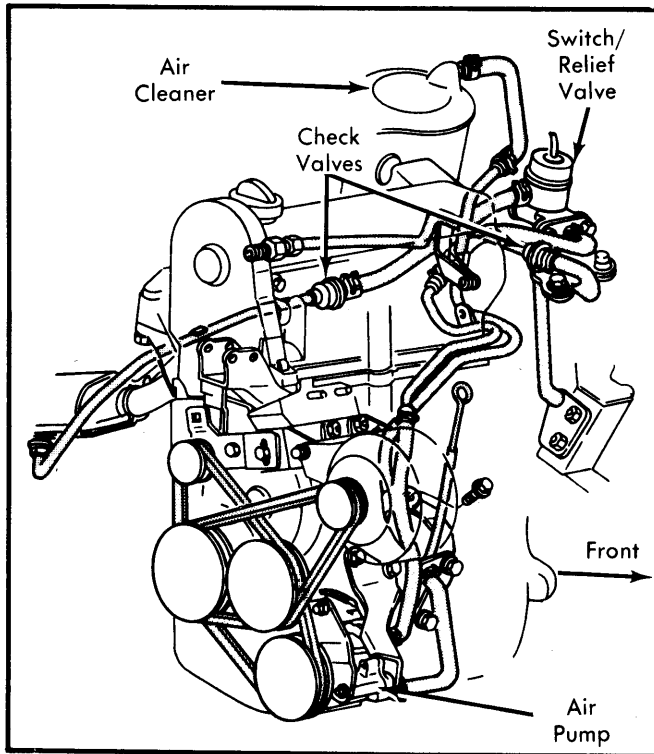

Fig. 3 Air Pump Injection System (1.7L Engine)

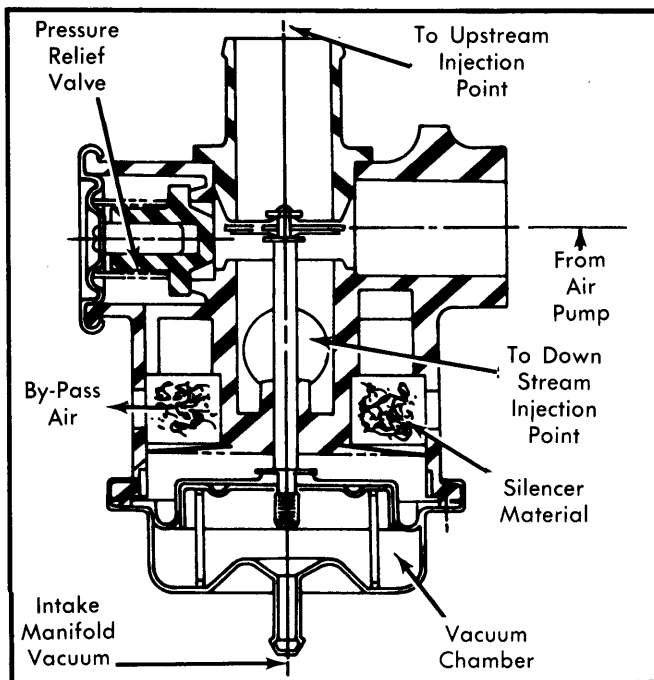

Fig. 4 Cutaway View of Air Switching Valve

### CHECK VALVE

This valve is located in injection tube assemblies that lead to exhaust manifold. Valve has a one-way diaphragm which prevents hot exhaust gases from backing up into hose and pump.

This valve will protect system in event of pump belt failure, abnormally high exhaust system pressure or air hose rupture.

### TESTING

#### PULSE AIR FEEDER VALVE

With engine operating, remove hose from air cleaner and check for vacuum at hose opening by covering with hand. If no vacuum is generated, check hoses for leak and evidence of oil leaks.

#### AIR SWITCHING VALVE

With engine running, apply vacuum to valve. Air should be injected upstream only. If air escapes from silencer ports or is applied both upstream and downstream, valve is faulty and must be replaced.

To check vacuum supply system, observe engine vacuum at idle with engine cold. Vacuum should be present until engine reaches normal operating temperature. With engine warm, vacuum should only be present for a limited time after engine starts. See *Chrysler Electronic Ignition Systems*.

#### CHECK VALVE

To check operation of this valve, remove air supply hose from pump at distribution manifold. With engine operating, listen for exhaust leakage at check valve which is connected to distribution manifold.

### SERVICE PROCEDURES

**CAUTION** — DO NOT LUBRICATE PUMP. Wipe all oil off of pump housing. Oil in the pump will cause rapid deterioration and failure.

Complete system should be checked at regular intervals. Engine tune-up should be checked whenever air injection system is not operating properly. Belts must be in good condition and set to proper tension.

**Air Pump** — Servicing of air pump is limited to replacement of centrifugal fan filter (if equipped) or the entire pump. Do not clamp pump in vise or use hammer on pump housing. To replace centrifugal filter, insert needle nose pliers between filter fins and break fan from hub. Install new fan, using pulley and bolts to draw down fan evenly.

**NOTE** — Fan may have slight squeal until sealing lip is worn in. Air injection system is not completely noiseless. Normal noise increases in pitch as engine speed increases.

**CAUTION** — If engine or compartment is to be cleaned with steam or high pressure liquids, fan filter should be masked off to prevent liquids from entering air pump.