

1982 Fuel Injection

FORD MOTOR CO. ELECTRONIC FUEL INJECTION

Lincoln
Mark VI
Town Car

DESCRIPTION

The Ford electronic fuel injection system (EFI) basically consists of 4 sub-assemblies: Fuel delivery, air induction, engine sensors and the Electronic Engine Control (EEC-III) system computer (ECA). The fuel delivery system includes an in-tank high pressure fuel pump, a primary fuel filter, a secondary fuel filter, fuel supply and return lines, fuel injectors and fuel pressure regulator.

The air induction system includes the throttle body, intake manifold and the cold engine speed control. Engine sensors are as follows: Throttle position sensor (TPS), barometric and manifold absolute pressure sensors (B/MAP), engine coolant temperature sensor (ECT), air charge temperature sensor (ACT), EGR valve position sensor (EVP), crankshaft position sensor (CP) and exhaust gas oxygen sensor (EGO).

OPERATION

FUEL DELIVERY

A high pressure electric fuel pump, located inside fuel tank, supplies fuel to the injectors. The pump receives power through

a vacuum controlled by-pass relay, a fuel pump relay, and an inertia switch. The vacuum controlled relay is activated by a vacuum switch connected to manifold vacuum. This supplies power to the fuel pump relay only when engine is running and vacuum is present in manifold.

The fuel pump relay is activated by the ECA with the ignition switch in the "ON" or "START" mode. When the ignition switch is turned to the "ON" position, both relays are activated for approximately 1 second to supply initial line pressure to the system. If the engine stalls or is not started within 1 second the ECA will shut off power to fuel pump.

The inertia switch, located in the trunk, is designed to open the fuel pump power circuit in the event of a collision. This switch is reset by pushing both buttons, on switch, simultaneously. The inertia switch should not be reset until fuel system has been inspected for damage or leaks.

Fuel is pumped through fuel filters to the fuel injectors and pressure regulator mounted on throttle body. The fuel pressure regulator controls fuel pressure to 39 psi across the fuel injectors. Fuel in excess of that used to maintain constant pressure is returned to fuel tank through the fuel return line.

Injectors are actuated, spraying calculated amount of fuel into engine, at twice the crankshaft speed. Only open time varies to satisfy fuel requirements.

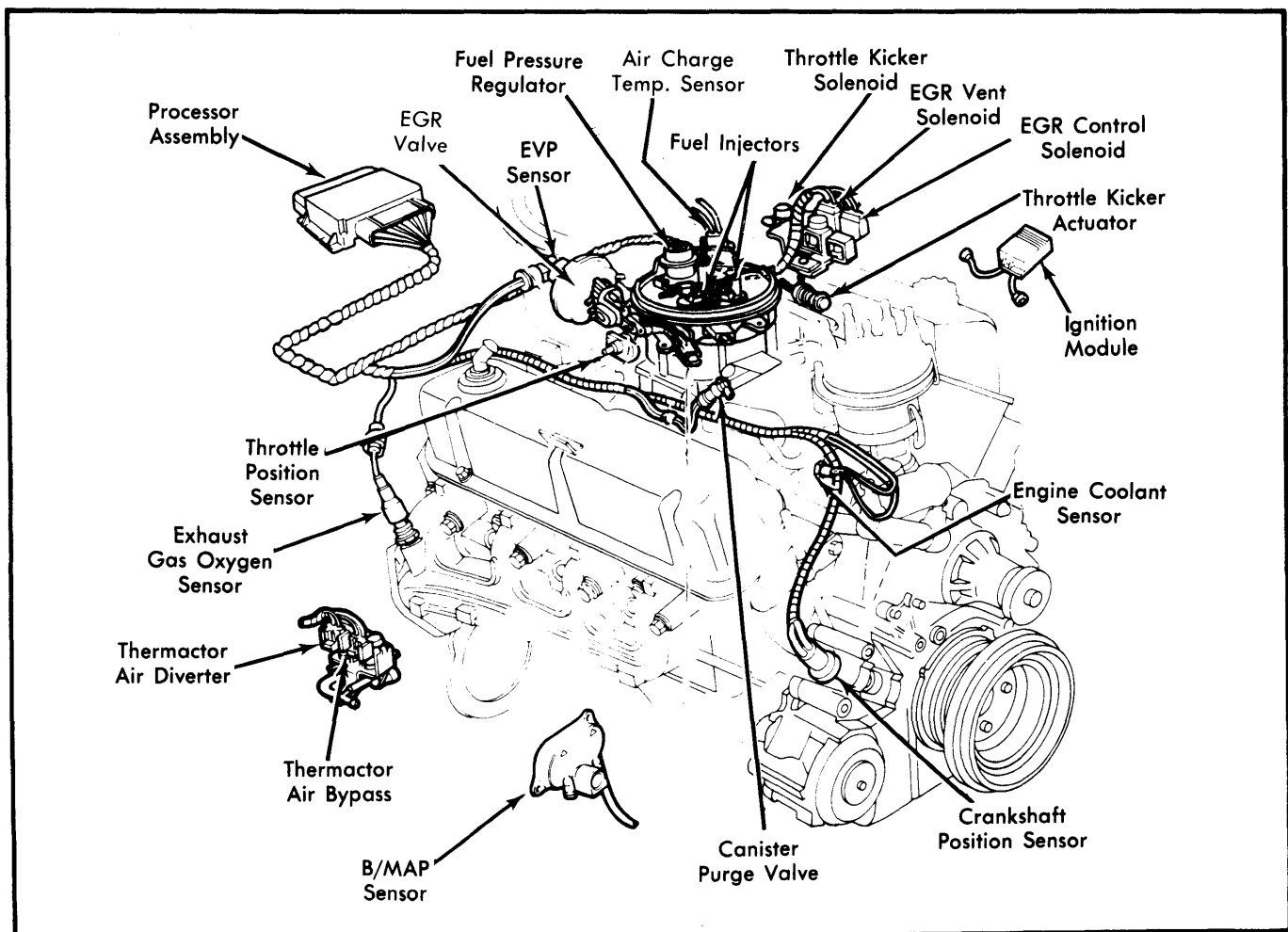

Fig. 1 View of Engine Showing EEC-III/EFI Components

FORD MOTOR CO. ELECTRONIC FUEL INJECTION (Cont.)

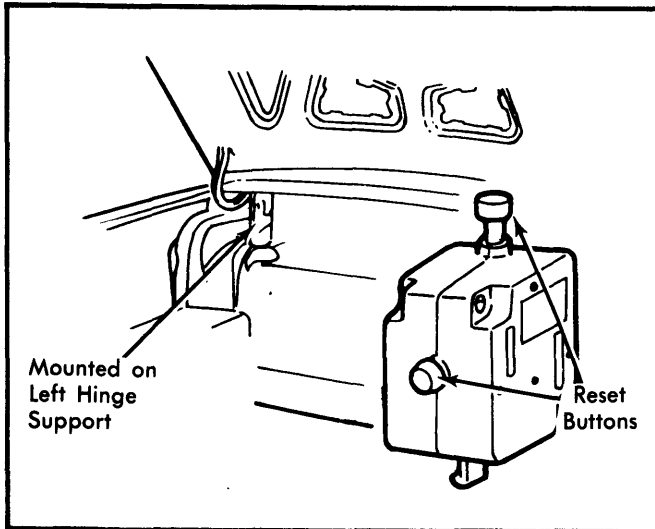

Fig. 2 Inertia Switch Location

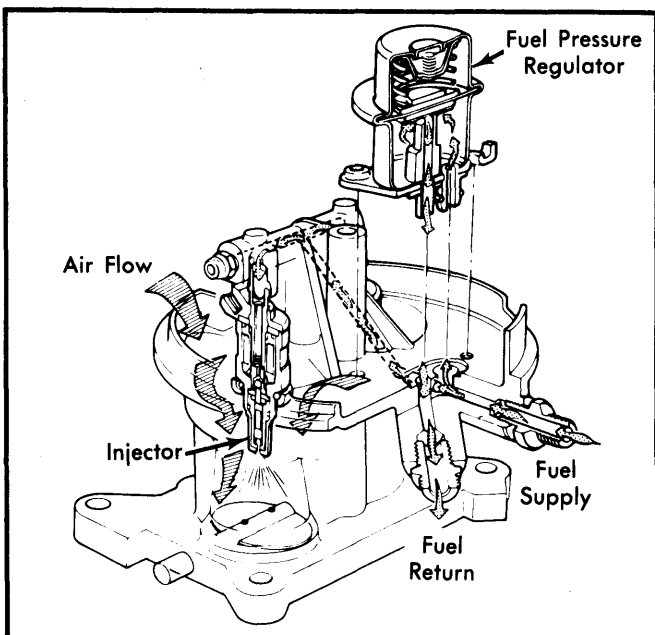

Fig. 3 Fuel Charging Operation

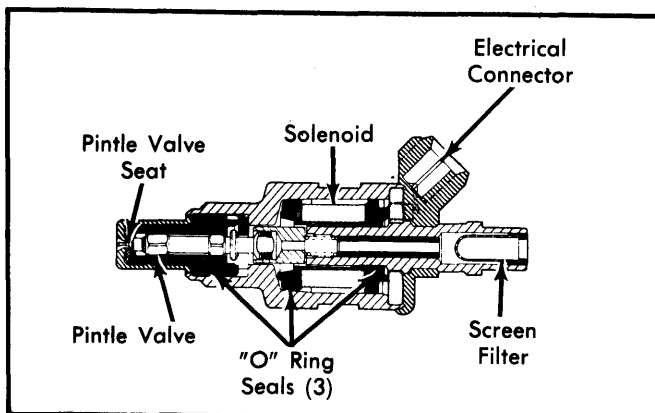

Fig. 4 Cutaway View of Injector Valve

AIR INDUCTION

Air enters the engine through the throttle body at a rate controlled by the throttle valves, which are connected to the accelerator linkage. Fast idle speed position of the throttle valves is controlled by a fast idle cam connected to and positioned by a bimetal spring (similar to a conventional automatic choke bimetal). The fast idle cam drops, reducing fast idle, as bimetal is heated by an electric heating element and is assisted by a vacuum controlled kickdown mechanism.

ENGINE SENSORS

Throttle Position Sensor (TPS) — The TPS is mounted on the side of throttle body directly connected to throttle shaft. The TPS senses throttle movement and position and transmits appropriate electrical signal to ECA. These signals are used by the ECA to determine proper fuel/air mixture, spark and EGR operation.

Barometric & Manifold Absolute Pressure Sensors (B/MAP) — The B/MAP sensor assembly is located on the right fender panel in the engine compartment. The barometric sensor signals ECA of changes in atmospheric pressure and density to regulate calculated air flow into engine. The MAP sensor monitors and signals ECA of changes in intake manifold pressure which result from engine load, speed and atmospheric pressure changes.

Engine Coolant Temperature Sensor (ECT) — The ECT, threaded into intake manifold water jacket directly above water pump by-pass hose, monitors and signals ECA of water temperature. The ECA uses these signals for mixture enrichment during cold operation, ignition timing and EGR operation.

Air Charge Temperature Sensor (ACT) — The ACT, threaded into intake manifold air runner directly below accelerator linkage, monitors and signals ECA of air/fuel charge temperatures. This signal is used by ECA to correct fuel enrichment for air density changes.

EGR Valve Position Sensor (EVP) — The EVP, mounted to EGR, signals ECA of EGR opening so ECA can subtract EGR flow from total flow into manifold. This excludes EGR flow from being computed into mixture requirements.

Crankshaft Position Sensor (CP) — To provide ECA with an accurate ignition timing reference (when piston reaches 10° BTDC) and injector operation (twice each crankshaft revolution), the crankshaft vibration damper is fitted with a four lobe "pulse ring". As the crankshaft rotates, the pulse ring lobes interrupt magnetic field at tip of CP sensor (mounted on right front of engine).

Exhaust Gas Oxygen Sensor (EGO) — The EGO monitors oxygen content of exhaust gases and sends a constantly changing voltage signal to ECA. The ECA analyzes signal and changes air/fuel mixture accordingly.

ELECTRONIC CONTROL ASSEMBLY (ECA)

The ECA is solid state micro-computer consisting of a processor assembly and a calibration assembly. This unit is located in the passenger compartment under the instrument panel, to the left of the steering column. The ECA is the "brain" of the EEC-III/EFI system.

FORD MOTOR CO. ELECTRONIC FUEL INJECTION (Cont.)

Processor Assembly — The processor assembly is housed in an aluminum case and contains circuits designed to continuously sample input signals from sensors, calculate and send out proper control signals to adjust air/fuel ratio, spark timing and emission system operation. The processor also provides a continuous reference voltage of 8.0-10.0 volts to some of the sensors (B/MAP, EVP and TPS).

Calibration Assembly — The calibration assembly is contained in a black plastic housing which plugs into the top of the processor assembly. It contains the "memory" and programming used to provide the processor assembly with operating information for that particular vehicle and recalls information from its memory when required.

NOTE — Different calibration information is used in different vehicle applications, such as 49 States and California.

TESTING & DIAGNOSIS

NOTE — Due to the complexity of the EEC III system, full testing cannot be done unless a special tester is used. Instructions for testing come with the tester, which is available from Owatonna Tool Co. However, some checks can be made using regular shop equipment. These checks are outlined in the following procedures.

TESTING NOTES & CAUTIONS

NOTE — No repairs or adjustments can be made to the ECA components. If diagnosis shows Processor or Calibration units are not functioning properly, they must be replaced.

CAUTION — Shorting the wiring harness across a solenoid valve can burn out circuitry in the ECA that controls the solenoid valve actuator.

CAUTION — The EEC system contains transistors which CANNOT tolerate excessive voltage surges or transient voltage. Never try to jump-start the vehicle with 24 volts.

CAUTION — Fuel supply lines will remain pressurized for long periods of time after key is turned off. This pressure must be relieved before servicing fuel system by removing air cleaner and cautiously depressing pin in schrader valve on fuel charging main body. This will expel fuel into throttle body.

BASIC EEC-III/EFI TROUBLE SHOOTING

- 1) Perform basic ignition system and fuel system checks to ensure there is fuel and spark.
- 2) Remove air cleaner assembly and inspect all vacuum and pressure hoses for proper connection to fittings, or any broken, cracked or pinched conditions.

3) Inspect EFI sub-system wiring harnesses for proper connections to the EGR solenoid valves. Red wire to both, yellow wire to vacuum solenoid and dark green wire to vent solenoid.

4) Check for any loose or detached connectors, broken or detached wires. Ensure all terminals are seated firmly and are not corroded. Check for partially broken or frayed wires or any shorting between wires.

5) Inspect sensors for physical damage. Inspect vehicle electrical system. Check battery for full charge and battery cable connections for tightness.

6) Inside passenger compartment, check to make sure the ECA power relay is securely attached and making a good ground connection.

FUEL PUMP OPERATION

Fuel Pump Electrical Continuity — 1) Disconnect electrical connector just forward of fuel tank. Connect voltmeter to body wiring harness connector. Turn key on while watching voltmeter.

2) Voltage should rise to battery voltage, then return to zero volts after about 1 second. Momentarily turn key to "START" position. Voltage should rise to about 8 volts while cranking. If voltage is not as specified, check electrical system. See Fig. 5.

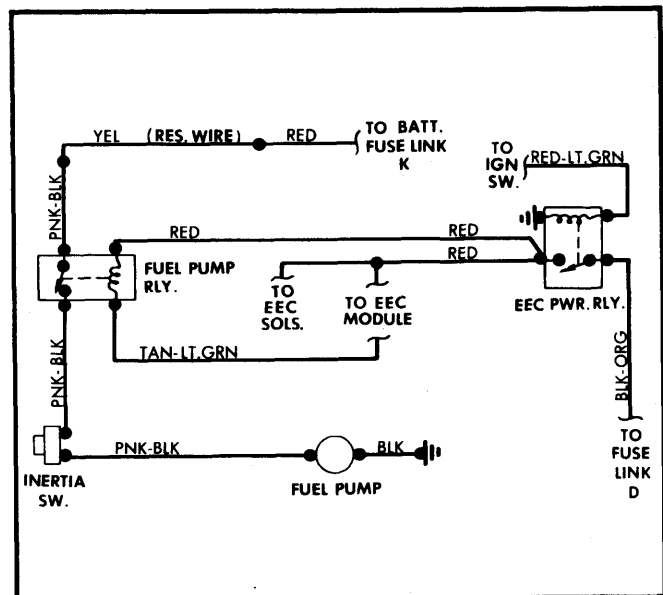

Fig. 5 Fuel Pump Wiring Diagram

Fuel Pump Operation — 1) Disconnect fuel return line at fuel charging main body and connect hose to a calibrated container (at least 1 quart capacity). Connect pressure gauge (T80L-9974-A or equivalent) to fuel pressure test fitting.

2) Disconnect electrical connector to fuel pump located ahead of fuel tank. Connect an auxiliary wiring harness to connector of fuel pump. Energize pump for 10 seconds by connecting

1982 Fuel Injection

FORD MOTOR CO. ELECTRONIC FUEL INJECTION (Cont.)

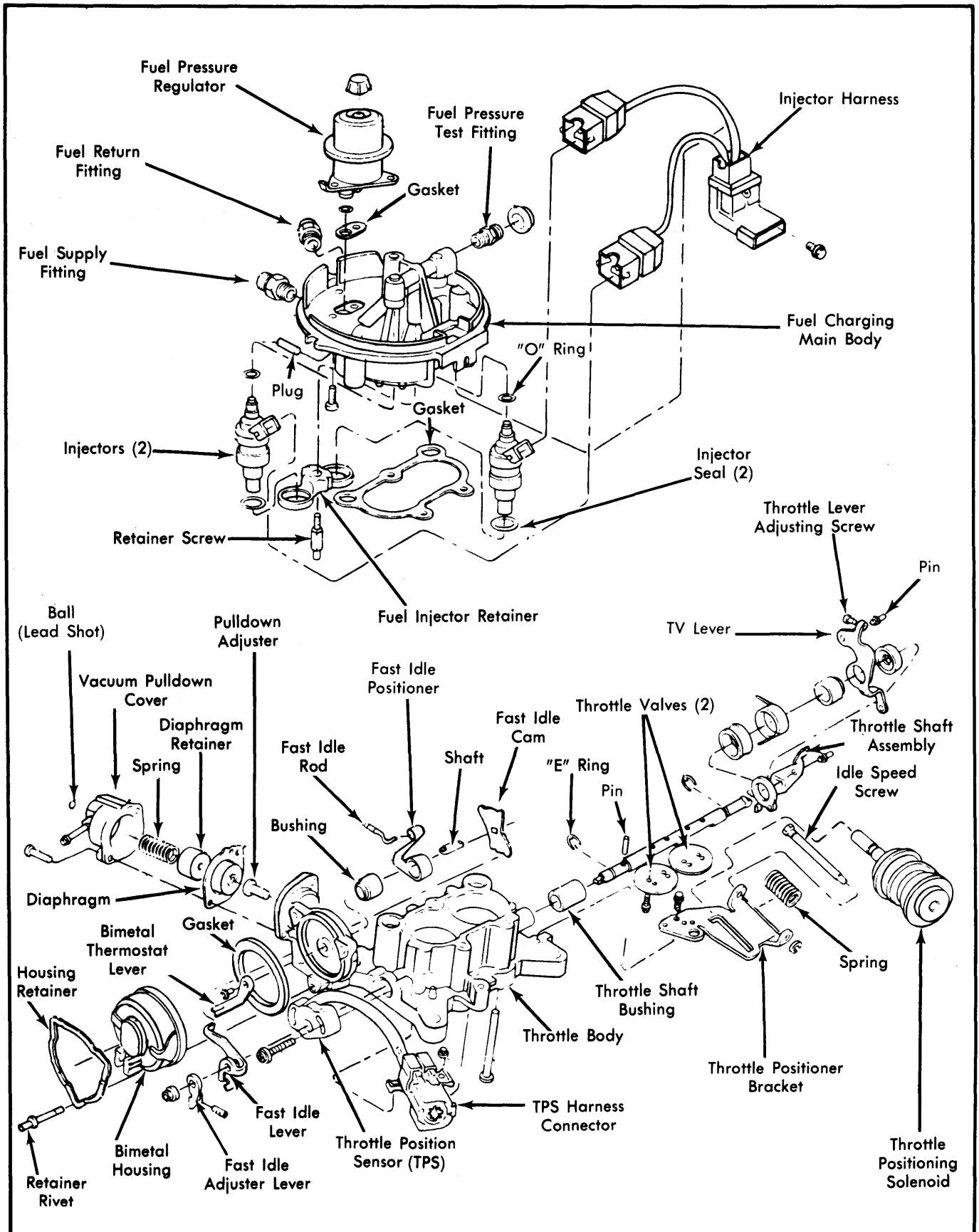

Fig. 6 Exploded View of Throttle Body and Fuel Charging Assembly

FORD MOTOR CO. ELECTRONIC FUEL INJECTION (Cont.)

auxiliary wiring harness to fully charged 12 volt battery. Observe fuel pressure while pump is energized. Allow fuel to drain into container and observe volume of fuel discharged. De-energize pump and note pressure.

3) The fuel pump is operating properly if fuel pressure reaches 35-45 psi; fuel flow is 10 ozs. in 10 seconds (minimum) and fuel pressure maintains minimum 30 psi immediately after de-energization. If all 3 conditions are met, check for engine and electrical problems.

4) If pressure condition is met, but fuel flow is not met, check for blocked filter(s) and fuel supply lines. After correcting problem, repeat test procedure. If fuel flow still does not meet specifications, replace fuel pump.

5) If flow specification is met, but pressure is not met, check for worn or damaged pressure regulator valve on throttle body. If both pressure and fuel flow specifications are met, but pressure will not maintain after de-energization, check for leaking injector valve(s) and/or pressure regulator valve. If injector valve(s) and pressure regulator valve are okay, replace fuel pump.

INJECTOR PRESSURE TEST

1) Connect pressure gauge to fuel pressure test fitting. Disconnect coil connector from coil. Disconnect electrical lead from 1 injector and pressurize fuel system. Disable fuel pump by disconnecting inertia switch or fuel pump relay. Observe pressure gauge reading.

2) Crank engine for 2 seconds. Turn ignition off and wait 5 seconds, then observe pressure drop. If pressure drop is between 2-16 psi, injector is operating properly. Reconnect injector, activate fuel pump, then repeat procedure for other injector.

3) If pressure drop is less than 2 psi or more than 16 psi, switch electrical connectors on injectors and repeat test. If pressure drop does not meet specification of 2-16 psi, replace disconnected injector with same color code, then reconnect both injectors properly and repeat test.

FUEL PRESSURE REGULATOR TEST

Reconnect coil connector at coil and inertia switch or fuel pump relay. Reconnect injectors properly. Connect pressure gauge. Start engine and run at idle. Observe pressure reading. Pressure reading should be 35-45 psi. If not to specification, check fuel lines for kinks and perform Fuel Pump tests.

MARGINAL INJECTOR TEST

1) Disconnect and plug vacuum hose to EGR valve. Start and run engine at 1800 RPM. Disconnect left injector electrical connector. Note RPM after engine stabilizes around 1200 RPM. Reconnect left injector and allow engine to return to 1800 RPM.

2) Perform same procedure for right injector. Note difference between RPM readings of left and right injector. If difference is

100 RPM or less, check oxygen sensor. If difference is more than 100 RPM, replace both injectors.

NOTE — Refer to "FORD MOTOR CO. MCU ENGINE CONTROL SYSTEM" in Computerized Engine Controls section for test of oxygen sensor.

REMOVAL & INSTALLATION

CAUTION — Fuel system is under approximately 39 psi; therefore, valve at end of fuel rail should be covered when relieving pressure in fuel lines.

THROTTLE BODY ASSEMBLY

Removal — Remove air cleaner assembly. Relieve fuel pressure at schrader valve on end of injector rail. Remove all throttle control linkage, vacuum lines, fuel lines and electrical connections. Remove throttle body retaining nuts and throttle body.

Installation — Install throttle body assembly in reverse order of removal, using new gasket between throttle body and intake manifold. Check TV cable adjustment after replacement of throttle body assembly.

FUEL INJECTORS & FUEL PRESSURE REGULATOR

NOTE — Metric fasteners are painted blue.

Removal — 1) Remove throttle body assembly. Place on suitable stand, in inverted position. Remove 4 screws from base of throttle body and remove throttle body from upper fuel charging body.

2) Remove 3 fuel pressure regulator retaining screws and remove regulator. Remove nut holding injector retaining bracket to upper body and remove retaining bracket. Disconnect wiring harness from injectors and remove injectors from upper body, noting location of each.

Installation — 1) Replace injector "O" rings and lubricate with light oil. Push injectors into their original location, install retainer bracket and nut.

2) Replace pressure regulator "O" ring and gasket and lubricate "O" ring with light oil. Install pressure regulator and 3 screws. Install connectors to injectors and install throttle body to manifold.

FAST IDLE BIMETAL & PULLDOWN ASSEMBLY

Removal — 1) Drill rivet heads from bimetal cover retaining ring with a .128" (No. 30) drill. Drive remaining portion of rivet body from housing. Remove bimetal cover retaining ring and cover.

2) Remove 2 screws and fast idle pulldown cover. Remove spring, spring retainer and pulldown diaphragm.

FORD MOTOR CO. ELECTRONIC FUEL INJECTION (Cont.)

Installation — 1) Install pulldown diaphragm with vacuum passage in diaphragm toward top of housing. Holding spring and spring retainer on diaphragm, carefully install pulldown cover and screws.

2) Install fast idle control bimetal to original position. Position cap retainer on cap, making sure all holes line up. Install new retaining rivets (1/8" diameter by 1/2" long by 1/4" head).

FUEL PUMP

Removal — With fuel tank removed, disconnect supply and return lines and electrical connector. Using suitable tool, turn fuel pump lock ring counterclockwise and remove. Remove fuel pump assembly and seal. Discard seal.

NOTE — Whenever the fuel pump is removed from the tank, the rubber hoses, clamps and mounting gasket must be replaced. If not replaced, hoses could become brittle and deteriorate.

Installation — Install new seal and hold in place with heavy grease. Install gasket, pump unit and locking ring, making sure seal does not move. Reconnect fuel lines and electrical connector. Install fuel tank.

THROTTLE POSITION SENSOR (TPS)

Removal — Remove retaining nut from fast idle side of throttle shaft. Remove fast idle cam adjuster lever, fast idle actuating lever and "E" clip from throttle shaft. Scribe a locating mark on TPS and throttle body, remove TPS retaining screws and TPS.

Installation — Install TPS with scribe mark at 12 o'clock position. Holding firmly against throttle body, rotate into original position and install screws. Install "E" clip, fast idle levers and retaining nut.

ELECTRONIC CONTROL ASSEMBLY (ECA) & SENSORS

NOTE — No removal and installation procedures available from manufacturer. If engine sensors are removed, install using sealing compound on threads. Refer to Description and Operation in this story for locations.

ADJUSTMENTS

See appropriate article in TUNE-UP SERVICE PROCEDURES.

TIGHTENING SPECIFICATIONS

Application	INCH Lbs. (N·m)
Throttle Body-to-Intake Manifold	120 (14)
Fuel Pressure Regulator	30-40 (3-5)
Injector Bracket	30-60 (3-7)
Fast Idle Lever Nut	18 (2)
Pulldown Diaphragm Cover	18 (2)
Fuel Pressure Diagnostic Valve	48-84 (5-9)
Throttle Position Sensor	12 (1)