

## ROCHESTER E2MC & E2ME 2-BARREL

### CARBURETOR APPLICATION

#### GENERAL MOTORS (BUICK, CHEVROLET, GMC CABALLERO, OLDSMOBILE & PONTIAC)

Application	Rochester Carb. No.	
	Man. Trans.	Auto. Trans.
3.0L (181") VIN E V6 (E2ME)		
Nationwide .....		17082196
3.8L (229") VIN K V6 (E2ME)		
Nationwide		
Without A/C .....		17082130
With A/C .....		17082132
3.8L (231") VIN A V6 (E2ME)		
Nationwide .....		17082182, 184 17082192, 194
4.3L (260") VIN 8 V8 (E2MC)		
Nationwide .....		17082150
4.4L (267") VIN J V8 (E2ME)		
Nationwide		
Without A/C .....		17082138
With A/C .....		17082140

### CARBURETOR IDENTIFICATION

Carburetor model identification is stamped vertically on left rear corner of float bowl. Be sure to follow manufacturer's instructions on transferring identification number if new float bowl is to be installed on original carburetor.

The E2MC and E2ME are used nationwide in conjunction with General Motors Computer Command Control (CCC) system. The first letter "E" means the carburetor is a part of the CCC system. The last letter, if "E", indicates the carburetor has an electric choke, or, if "C", indicates the model has a hot-air choke.

### DESCRIPTION

The Rochester E2MC and E2ME are single-stage, downdraft, 2-barrel (dualjet) carburetors. They feature five basic systems, the float, idle, main metering (part throttle), pump and choke systems.

The Computer Command Control system provides precise control of carburetor air/fuel mixtures during all ranges of engine operation. An electrically operated mixture control solenoid, mounted in the fuel bowl, controls air and fuel metered to the idle and main metering systems. Fuel metering is controlled by 2 special stepped metering rods, operating in removable jets, positioned by a plunger in the mixture control solenoid.

The mixture control solenoid plunger is controlled by electrical signals received from the CCC system's electronic control module (ECM). Upon receipt of information from the oxygen sensor, the ECM energizes the solenoid to move the plunger and rods down to the lean position or de-energizes it to move them up to the rich position. At the same time, air metering to the idle system is controlled by the air bleed valve located in the air horn. It follows the movement of the mixture control solenoid plunger to control the amount of air bled into the idle system to richen or lean the mixtures. Air/fuel mixtures are constantly monitored and adjusted as a result of changes in exhaust gas oxygen content.

A throttle position sensor (TPS), mounted in the float bowl, signals the ECM of changes in throttle position. The ECM then refers to its memory and "holds" the last known air/fuel mixture ratio for good engine response during throttle changes.

All models include tamper-resistant factory settings of the mixture control solenoid, mixture rich stop screw, idle air bleed valve, TPS and idle mixture needles. No attempt should be made to adjust these except during major carburetor overhaul or replacement of air horn, float bowl or throttle body. Both electric and hot air chokes have riveted covers which must not be removed except for major overhaul.

The 4.3L engine is equipped with an Idle Load Compensator (ILC) attached to the fuel bowl. The ILC adjusts curb idle speed by sensing changes in manifold vacuum (engine load). To prevent the ILC from reacting too quickly to vacuum changes, a Differential Vacuum Delay Valve (DVDV) is installed between the ILC and vacuum source. The DVDV delays operation of the ILC until vacuum change is constant. All other engines may be equipped with an Idle Speed Control (ISC) on the fuel bowl. Controlled by the ECM, the ISC controls normal curb idle speed and acts as a dashpot on deceleration and throttle closing. On vehicles without ILC or ISC, but with air conditioning, an Idle Speed Solenoid (ISS) maintains a specific idle speed during A/C operation.

All carburetors are equipped with a front vacuum break with a leaf-type bucking spring. Some models may use both a front and rear vacuum break to control choke valve openings during initial engine starting and cold driveaway.

### TESTING

#### ELECTRIC CHOKE

**NOTE** — This test should be performed when air temperature is 60-80°F (15-27°C).

1) Allow choke to cool to permit full closing of choke blade when throttle is opened slightly. Start engine and time the interval required for choke blade to reach full open position. (Start timing when engine starts). If choke blade does not fully open within 3½ minutes, proceed with test.

2) With engine running, check voltage at choke heater connection. If voltage is about 12-15 volts, replace electric choke unit. If voltage is low or zero, check all wires and connections and repair as required. Power for choke unit is through the oil pressure switch. Ensure switch circuitry is good.

3) If procedure in step 2) does not correct the problem, replace oil pressure switch.

#### HOT AIR CHOKE

1) Start and warm engine to normal operating temperature. Ensure choke valve fully opens. If valve does not fully open, check choke housing and hot air inlet to determine if sufficient heat is reaching choke coil.

**NOTE** — Choke housing and hot air inlet can become quite hot.

2) If choke housing and/or hot air inlet are cool, check for loss of vacuum to choke housing, restricted heat inlet in choke hous-

## ROCHESTER E2MC &amp; E2ME 2-BARREL (Cont.)

ing, restricted hot air inlet pipe or hose and restricted manifold choke heat stove passages. Repair or replace as required.

**DIFFERENTIAL VACUUM DELAY VALVE**

1) Using a "T" fitting, connect a vacuum gauge in vacuum line from valve to ILC. Connect a vacuum pump to port 1 of valve. Apply 17.8 in. Hg vacuum to port 1 and observe gauge. Gauge should read 16.9 in. Hg vacuum within 6-9 seconds. See Fig. 1.

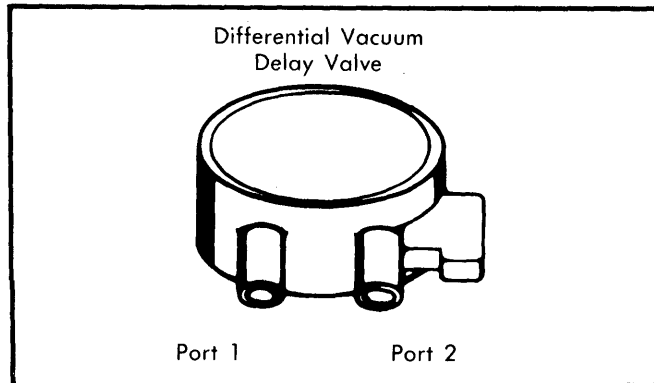

**Fig. 1 Location and Identification of Ports on Differential Vacuum Delay Valve**

2) Remove vacuum gauge and "T" fitting. Connect vacuum pump to port 2 and leave port 1 open. Air should flow through valve when .5 in. Hg vacuum is applied.

**IDLE SPEED SOLENOID (MODELS WITHOUT ISC)**

1) Turn ignition on but do not start engine. Turn A/C on. Open throttle to extend solenoid. Close throttle. Disconnect electrical lead at solenoid. Solenoid plunger should drop away from throttle lever.

2) Connect electrical lead to solenoid. Plunger should extend and contact throttle lever. Solenoid may not be strong enough to open throttle, but plunger should move.

3) If plunger does not respond as described, insert test lamp (1893 bulb or smaller) between solenoid feed wire and ground. If lamp glows, replace solenoid. If lamp does not glow, locate and repair open circuit in solenoid feed wire.

**ADJUSTMENT****HOT (SLOW) IDLE RPM**

See appropriate article in TUNE-UP SERVICE PROCEDURES.

**IDLE MIXTURE**

See appropriate article in TUNE-UP SERVICE PROCEDURES.

**COLD (FAST) IDLE RPM**

See appropriate article in TUNE-UP SERVICE PROCEDURES.

**IDLE AIR BLEED VALVE**

See appropriate article in TUNE-UP SERVICE PROCEDURES.

**IDLE LOAD COMPENSATOR (ILC), IDLE SPEED CONTROL (ISC) & IDLE SPEED SOLENOID (ISS)**

See appropriate article in TUNE-UP SERVICE PROCEDURES.

**THROTTLE POSITION SENSOR (TPS)**

See appropriate article in TUNE-UP SERVICE PROCEDURES.

**► ANGLE GAUGE ADJUSTMENT TOOL**

Manufacturer recommends that some carburetor adjustments be performed using a choke valve angle gauge (Kent-Moore tool No. J-26701). While preparations and actual adjustments may vary with each individual adjustment, the procedure for using the angle gauge to check the choke valve angle remains the same. Use the following procedure to perform adjustments requiring the use of the choke valve angle gauge.

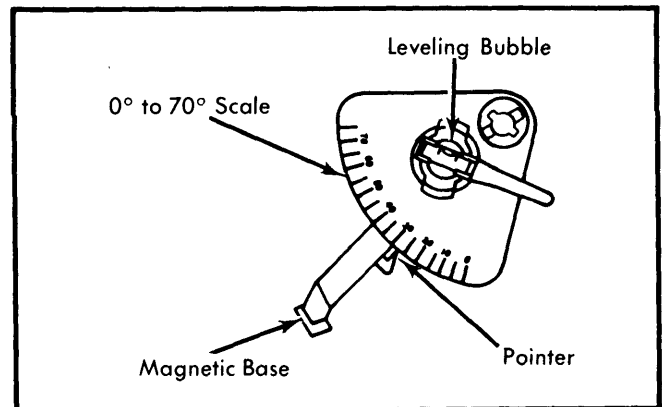

**Fig. 2 Choke Valve Angle Gauge**

1) Rotate degree scale on angle gauge so that 0° mark is opposite pointer.

2) With choke valve closed, place angle gauge magnet squarely on choke valve.

3) Rotate leveling bubble on angle gauge until it is centered.

4) Rotate degree scale until specified degree mark is opposite pointer.

5) Now perform individual adjustment preparations as outlined in the following carburetor adjustments requiring angle gauge. If bubble is centered, adjustment is correct. If not, adjust carburetor as outlined.

**FLOAT LEVEL**

1) Remove air horn and gasket from float bowl. Hold float retainer down firmly. See Fig. 3.

2) Position a "T" scale over toe of float at a point  $\frac{3}{16}$ " from end of float toe. Measure distance from float bowl casting to top of float.

3) If float level setting varies more than  $\frac{1}{16}$ " from specified setting, proceed as follows:

**Float Level Too High**

a) Hold float retainer clip firmly in place.

b) Push down on center of float pontoon until correct float level setting is obtained.

**Float Level Too Low**

a) Lift out metering rods. Remove solenoid connector screws.

## ROCHESTER E2MC & E2ME 2-BARREL (Cont.)

- b) Turn lean mixture solenoid screw clockwise, counting and recording number of turns required to lightly seat screw in float bowl.
- c) Turn screw counterclockwise and remove. Lift solenoid and connector from float bowl.
- d) Remove float and bend arm up to adjust. Make sure float is correctly aligned after adjustment.
- e) Reinstall components in reverse order that they were removed. Back out solenoid mixture screw number of turns noted in step b).

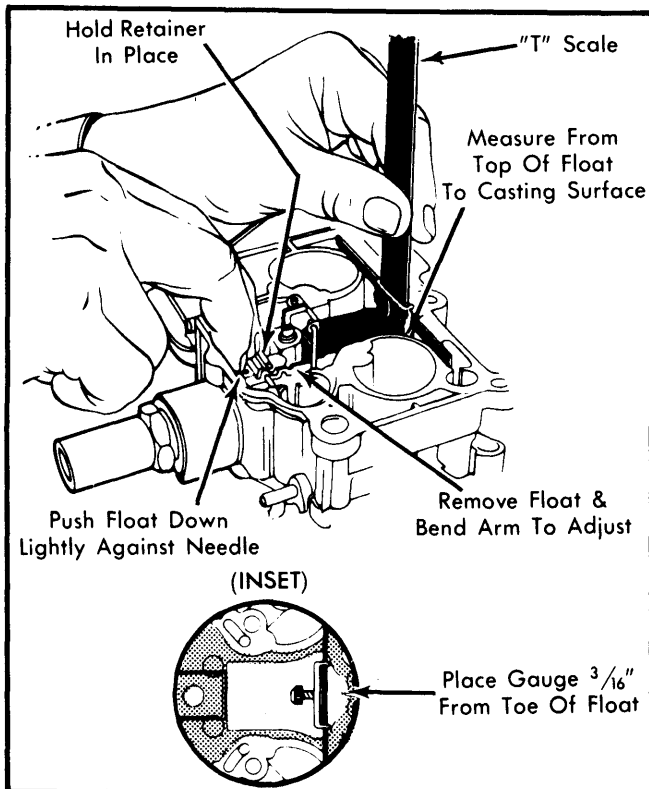

Fig. 3 Adjusting Float Level

### ACCELERATOR PUMP

No pump adjustment is required on carburetors for the Computer Command Control system.

### CHOKE COIL LEVER

**NOTE** — Choke coil cover uses rivets in place of retaining screws. If necessary to remove choke coil cover, refer to Disassembly and Reassembly procedures in this Section.

- 1) Remove retaining rivets. Remove choke cover and coil from choke housing. See Fig. 4.
- 2) Position fast idle speed cam follower on high step of fast idle cam.
- 3) Push up (counterclockwise) on choke coil tang until choke valve is closed.
- 4) Insert specified drill or pin gauge in hole provided in choke housing. Lower edge of choke lever inside housing should just touch drill or pin gauge.

- 5) To adjust, bend choke rod at point shown in illustration.

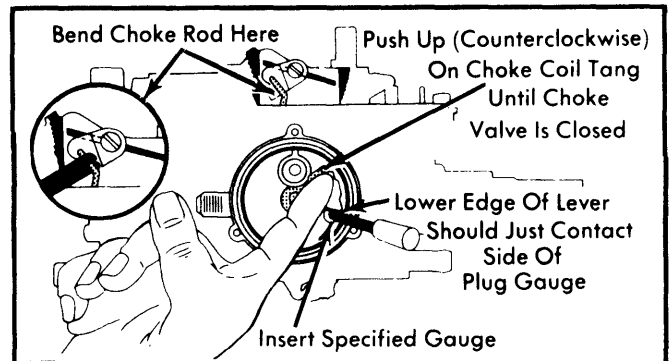

Fig. 4 Adjusting Choke Coil Lever

### FAST IDLE ADJUSTMENT (BENCH SETTING)

**NOTE** — This is a preliminary adjustment only. It is required to ensure that other adjustments are made with fast idle speed approximately correct. Final Cold (Fast) Idle Speed adjustment must be made with carburetor installed and engine running. See appropriate article in TUNE-UP Section.

- 1) Position fast idle speed cam follower on highest step of fast idle cam. Back off fast idle speed screw until screw moves away from cam follower.
- 2) Turn fast idle screw in until it just contacts lever, then turn in an additional 3 turns. See Fig. 5.

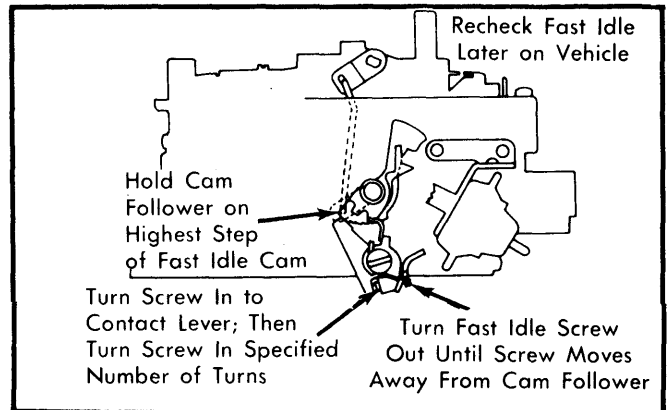

Fig. 5 Adjusting Fast Idle (Bench Setting)

### CHOKE ROD (FAST IDLE CAM)

**NOTE** — Choke coil lever and fast idle adjustments must be correct before performing this adjustment. Adjustment is performed with choke valve angle gauge. See procedure at beginning of Adjustments.

**CAUTION** — Do not remove rivets and choke cover to perform this adjustment. Use rubber band on vacuum break lever tang to hold choke valve closed.

- 1) Place fast idle speed cam follower on second step of fast idle cam against shoulder of highest step. See Fig. 6.

## ROCHESTER E2MC &amp; E2ME 2-BARREL (Cont.)

- 2) Close choke by pushing up on choke coil lever or vacuum break lever tang. Hold choke closed with a rubber band.
- 3) Bubble on choke angle gauge should be centered with specified angle mark opposite pointer.
- 4) To adjust, bend tang on fast idle cam until bubble of choke valve angle gauge is centered.

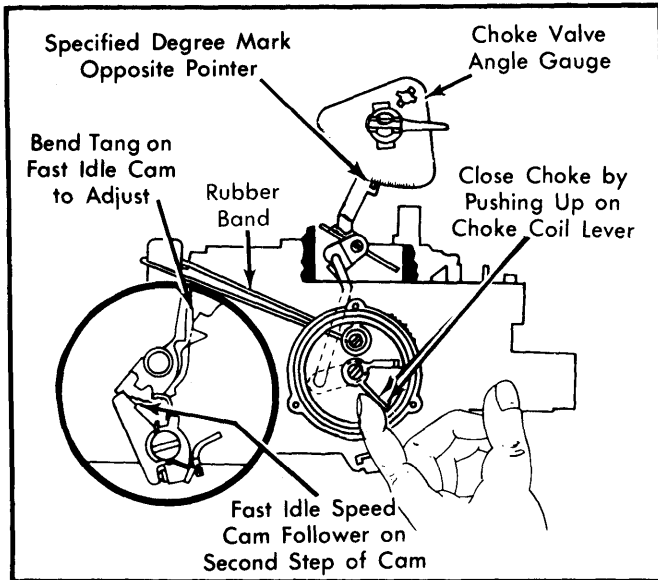
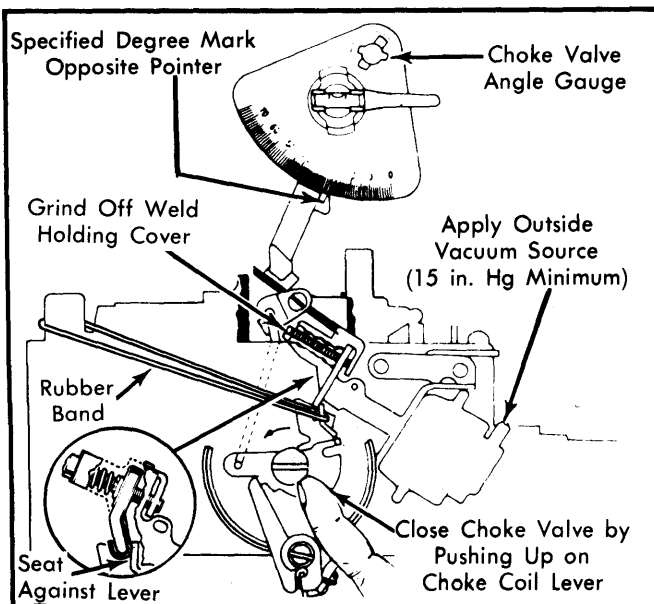

**Fig. 6 Adjusting Choke Rod (Fast Idle Cam)**

## PRIMARY (FRONT) VACUUM BREAK

**NOTE** — Choke coil lever and fast idle adjustments must be correct before performing this adjustment. Adjustment is performed with choke valve angle gauge. See procedure at beginning of Adjustments.

**CAUTION** — Do not remove rivets and choke cover to perform this adjustment. Use rubber band on vacuum break lever tang to hold choke valve closed.



**Fig. 7 Adjusting Front Vacuum Break**

- 1) Using an outside vacuum source of at least 15 in. Hg, seat primary (front) vacuum break diaphragm. Be sure leaf bucking spring is seated against lever, if equipped. See Fig. 7.

**NOTE** — On models equipped with air bleed, remove rubber cover from filter and plug vacuum tube with a piece of tape. If bleed hole is in end of diaphragm, plug hole in end of diaphragm with a piece of tape. Remove tape after completing adjustment.

- 2) Close choke by pushing upward on choke coil lever or vacuum break lever tang. Hold choke closed with rubber band.
- 3) Bubble on choke angle gauge should be centered with specified degree mark opposite pointer.
- 4) To adjust, turn vacuum break adjustment screw until bubble of choke valve angle gauge is centered.

## SECONDARY (REAR) VACUUM BREAK

**NOTE** — Choke coil lever and fast idle adjustments must be correct before performing this adjustment. Adjustment is performed with choke valve angle gauge. See procedure at beginning of Adjustments.

**CAUTION** — Do not remove rivets and choke cover to perform this adjustment. Use rubber band on vacuum break lever tang to hold choke valve closed.

- 1) Using an outside vacuum source of at least 15 in. Hg, seat vacuum break diaphragm. Be sure leaf bucking spring is compressed, if equipped. See Fig. 8.

**NOTE** — On models equipped with air bleed, remove rubber cover from filter and plug vacuum tube with a piece of tape. If bleed hole is in end of diaphragm, plug hole in end of diaphragm with tape. On delay models with air bleed, plug end cover with an accelerator pump plunger cup. Remove tape or cup after completion of adjustment.

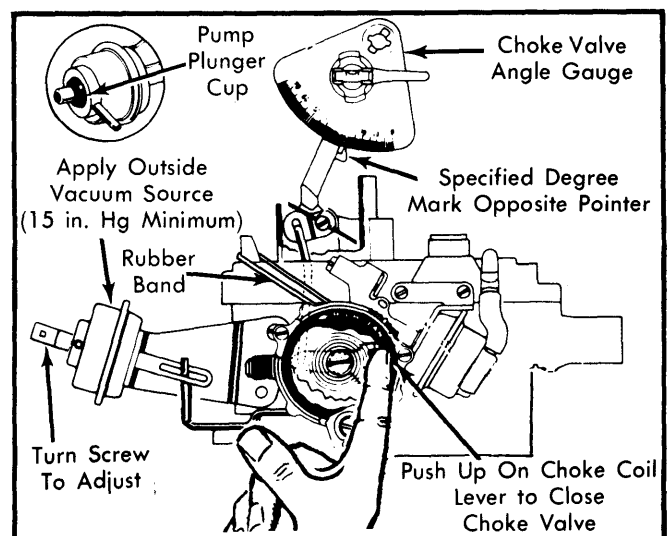

**Fig. 8 Adjusting Rear Vacuum Break**

- 2) Close choke by pushing up on choke coil lever or vacuum break lever tang. Hold choke closed with a rubber band.

## ROCHESTER E2MC & E2ME 2-BARREL (Cont.)

3) Bubble on choke angle gauge should be centered with specified degree mark opposite pointer.

4) To adjust, use a  $\frac{1}{8}$ " hex wrench to turn adjustment screw in rear cover of vacuum break unit until bubble of choke valve gauge is centered.

**NOTE** — Do not attempt to adjust rear vacuum break by bending link, which is a new non-bendable design.

### AUTOMATIC CHOKE

**NOTE** — Choke coil cover is retained in place with rivets. No adjustment is required. If necessary to remove choke coil cover, refer to Disassembly and Reassembly procedures in this Section. Only remove choke cover if major overhaul is required or if choke cover requires replacement.

### CHOKE UNLOADER

**NOTE** — Choke coil lever and fast idle adjustments must be correct before performing this adjustment. Adjustment is performed with choke valve angle gauge. See procedure at beginning of Adjustments.

**CAUTION** — Do not remove rivets and choke cover to perform this adjustment. Use rubber band on vacuum break lever tang to hold choke valve closed.

1) If removed, install choke thermostatic cover and coil assembly in choke housing, using special rivets in service kit. Hold throttle valves wide open. See Fig. 9.

2) Close choke by pushing up on vacuum break lever tang. Hold in position with a rubber band.

3) Bubble on choke valve angle gauge should be centered with specified degree mark opposite pointer.

4) To adjust, bend choke unloader tang on fast idle lever until bubble of choke valve angle gauge is centered. Remove gauge.

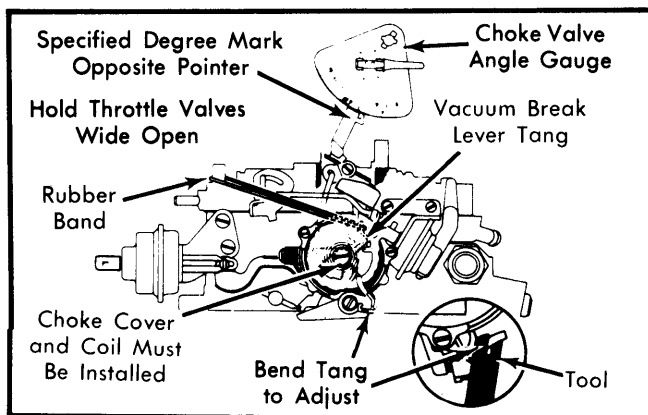

Fig. 9 Adjusting Choke Unloader

### MIXTURE CONTROL SOLENOID

1) Solenoid operation can be checked on vehicle using external float level gauge tool (J-9789-130). Some material must be removed from side of tool to allow for clearance in air horn.

2) Remove air cleaner and gasket. Insert gauge in "D" shaped hole in casting next to Idle Air Bleed Valve plug. Make sure gauge moves freely in hole.

3) Press down on gauge and release. With gauge released (solenoid up position), read inch mark on gauge that lines up with top of air horn casting and record reading.

4) Lightly press down on gauge until it bottoms (solenoid down position). Record inch mark on gauge that lines up with top of air horn casting.

5) Subtract solenoid up reading from solenoid down reading. Difference is total solenoid travel. Travel should be  $\frac{3}{32}$ – $\frac{5}{32}$ " ( $\frac{1}{8}$ " desired). If travel is correct, perform idle air bleed valve adjustments. See appropriate article in TUNE-UP SERVICE PROCEDURES.

6) To adjust travel, remove air horn. Turn lean mixture control solenoid screw in float bowl clockwise. Record number of turns required to lightly seat screw in float bowl.

7) If number of turns is not  $3\frac{1}{4}$ – $3\frac{3}{4}$ , solenoid travel is incorrect. Adjust screw to  $3\frac{1}{2}$  turns. Then invert air horn and using a small punch, drive mixture control solenoid screw plug out of air horn from bottom side. Discard plug.

8) Reinstall air horn and new gasket on float bowl and temporarily retain with 2 screws. Recheck solenoid plunger travel ( $\frac{3}{32}$ – $\frac{5}{32}$ "). If travel is correct, complete reassembly of air horn and proceed to step 11).

9) If solenoid travel is incorrect, remove and invert air horn assembly. Using adjusting tool (J-28696-4), remove rich mixture stop screw from bottom side of air horn. Then, drive screw plug out of air horn from bottom side. Discard plug. Reinstall rich mixture stop screw in air horn until screw is lightly bottomed.

10) Reinstall air horn and gasket on float bowl. Insert gauge in vent hole. Using adjusting tool (J-28696-10). Turn stop screw clockwise until total solenoid plunger travel is  $\frac{1}{8}$ ".

11) Once solenoid plunger travel is correctly set, install new plugs (supplied in service kit). Install mixture solenoid screw plug, hollow end down, into hole in raised boss of air horn casting. Use a small punch to drive plug into air horn until upper surface of plug is even with lower edge of hole chamfer. See Fig. 10.

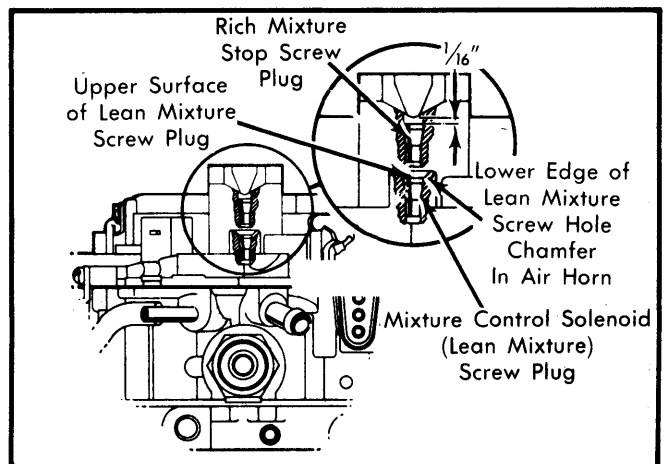

Fig. 10 Installing Lean and Rich Mixture Stop Screws in Air Horn

## ROCHESTER E2MC &amp; E2ME 2-BARREL (Cont.)

**NOTE** — Plug must be installed to retain the setting of the mixture control solenoid stop screw in float bowl and to prevent escape of fuel vapors.

12) If removed, install plug, with hollow end down, in air horn over rich mixture stop screw (located next to idle air bleed valve cover). Using a small punch, drive new plug into place until it is approximately  $\frac{1}{16}$ " below the surface of the air horn casting.

**NOTE** — Plug must be installed to retain setting of rich mixture stop screw.

## OVERHAUL

## DISASSEMBLY

**NOTE** — Place carburetor on a suitable working stand to avoid damaging throttle valves during overhaul.

**Air Horn** — 1) Remove ILC, ISC or ISS and bracket assembly. Remove upper choke lever from choke shaft end by removing screw. Rotate lever to remove choke rod from slot in lever. Remove choke rod from lower (inner) choke lever inside float bowl casting.

**NOTE** — Hold lever outward and twist rod counterclockwise to remove.

2) Using a drift punch, drive pump lever pivot pin inward until end of pin is against air cleaner locating boss on air horn casting. Remove pump lever and disconnect lever from pump link.

**CAUTION** — Be careful when removing roll pin to avoid damage to pump lever bosses.

3) Remove front (primary) vacuum break hose from tube on float bowl and mark for reassembly reference. Remove 7 air horn screws. Then remove 2 countersunk screws located next to venturi. Lift air horn straight up to remove. Gasket should remain on float bowl.

**CAUTION** — Use care not to damage mixture control solenoid connector, TPS adjustment lever, and small tubes protruding from air horn. Do not attempt to remove small tubes.

4) Remove front (primary) vacuum break diaphragm and bracket assembly. Remove TPS plunger by pushing plunger up through seal in air horn. Use fingers only to remove plunger to prevent damage to sealing surface. After removing air horn, lean mixture screw plug must be removed. To remove plug, invert air horn and drive out plug from bottom side. Discard plug.

**NOTE** — Do not turn rich mixture stop screw in air horn unless screw requires replacement or solenoid plunger travel is incorrect.

5) Remove TPS seal by inverting air horn and remove staking from around seal retainer with a small screwdriver. Remove and discard retainer and seal. Use care removing retainer and seal to prevent damage to air horn casting.

6) Further disassembly of air horn assembly is not required for cleaning purposes. Choke valve and choke valve screws should not be removed. The air horn has an idle air bleed valve which is preset at the factory and sealed. The idle air bleed valve

should not be removed from air horn unless "System Performance Check" of Computer Command Control system indicates need for adjustment or repair.

**NOTE** — Air horn assembly, with idle air bleed valve installed, should be cleaned only in low volatile cleaning solvent. Do not place air horn (with idle air bleed valve) in carburetor cleaner. No tamper-resistant plug should be removed during normal carburetor cleaning and servicing unless carburetor or mixture control solenoid has been diagnosed as cause of poor engine performance.

7) If necessary to replace idle air bleed valve or disassemble air horn for immersion in carburetor cleaner, drill off rivet heads of bleed valve cover with a .110" (No. 35) drill. Drive remainder of rivet out of tower with drift and small hammer. Lift out cover over valve and remove remaining rivet pieces from inside tower.

8) After removing cover, check for letter identification on top of idle air bleed valve. See Fig. 11. After identifying valve, use correct procedure as follows to remove valve:

- **No Letter On Valve** — Turn valve counterclockwise and remove from air horn.
- **Letter On Valve** — Turn valve clockwise until lightly seated in air horn, counting and recording number of turns for reassembly reference. Turn valve counterclockwise and remove from air horn.

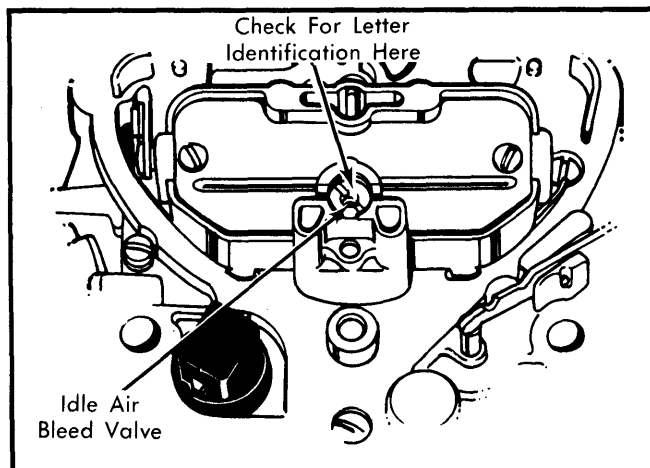

Fig. 11 Location of Idle Air Bleed Valve and Identification Letter

9) Remove and discard "O" ring seals from air bleed valve. Air bleed valve is serviced as a complete assembly only. Remove rich mixture stop screw and plug as previously described.

**Float Bowl** — 1) Remove solenoid metering rod plunger by lifting straight upward. Remove rubber seal from around mixture control solenoid connector. Remove air horn gasket by lifting out of dowel locating pins. Discard gasket.

2) Remove pump plunger and spring from pump well. Remove staking holding throttle position sensor in bowl. To do so, protect gasket sealing surface by laying a flat piece of metal across casting. Using a small screwdriver, lightly depress and hold TPS sensor down against spring tension. Carefully remove staking from around TPS sensor by prying upward with a small chisel against the metal piece (not bowl casting).

## ROCHESTER E2MC & E2ME 2-BARREL (Cont.)

3) Push up from bottom on electrical connector and remove TPS and connector assembly from bowl. Use care not to damage sensor during removal. Remove spring from bottom of TPS well in float bowl. Remove plastic filler block over float chamber.

4) Carefully remove each metering rod from metering jet. Make sure return spring is removed with each rod. Remove the spring by sliding off metering rod.

5) Remove mixture control solenoid-to-float bowl screws. Do not remove solenoid connector from float bowl at this time. Using adjustment tool (J-28696-10) on upper end of mixture control solenoid screw, turn screw clockwise until lightly seated in bowl, counting number of turns. Record number of turns for reassembly reference. Turn screw counterclockwise and remove. Carefully lift solenoid and connector assembly from bowl.

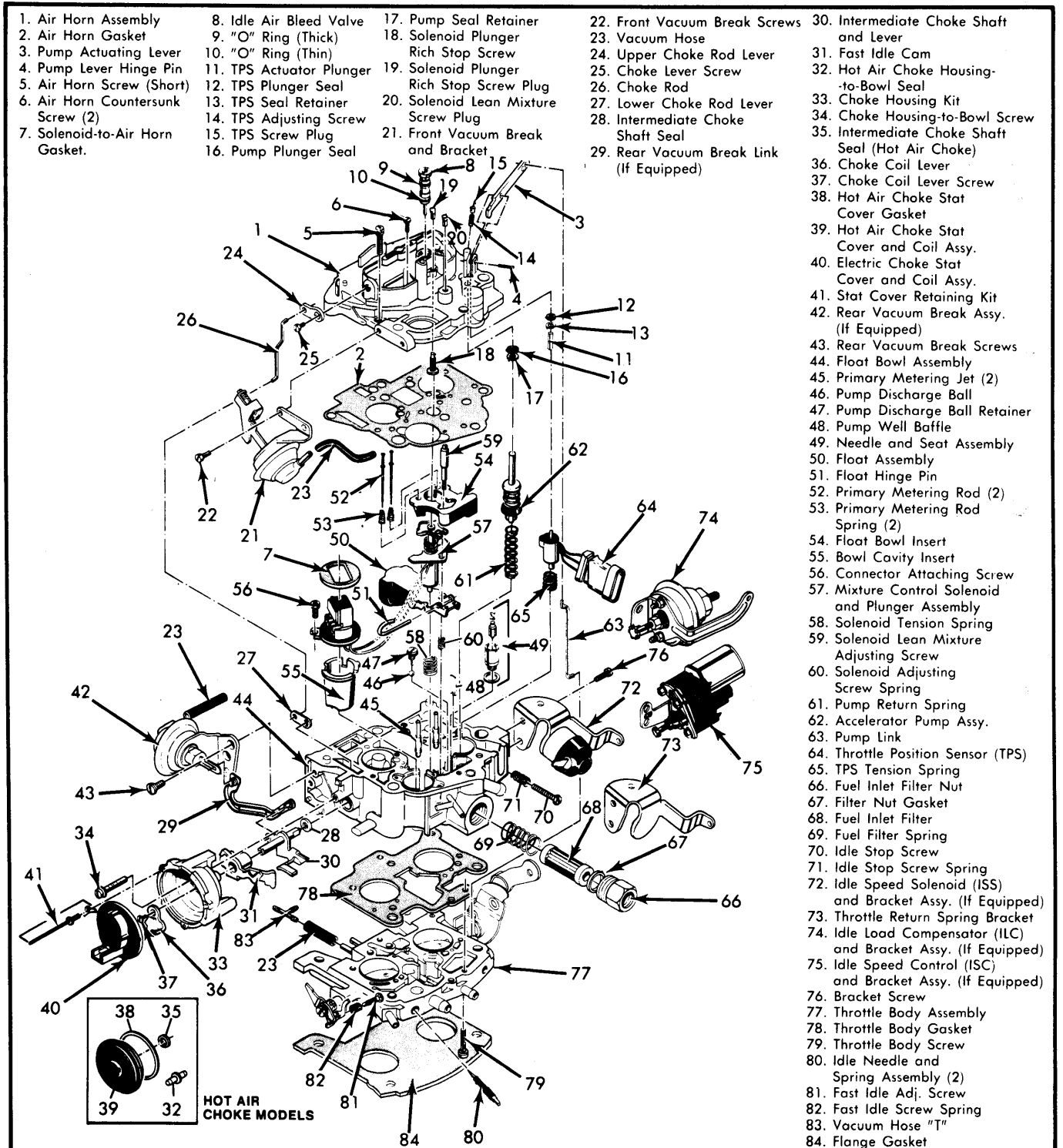

Fig. 12 Exploded View of Rochester E2MC and E2ME 2-Barrel Carburetor

## ROCHESTER E2MC &amp; E2ME 2-BARREL (Cont.)

**NOTE** — Do not remove plunger return spring or connector and wires from solenoid body. Solenoid and connector are serviced as an assembly.

6) If equipped, remove plastic insert from cavity in float bowl beneath solenoid connector. Remove solenoid screw tension spring (next to float hanger clip).

7) Remove float assembly and needle valve by lifting straight up on retaining clip. Remove needle valve seat and gasket.

8) Remove large mixture control solenoid tension spring from boss on bottom of float bowl located between metering jets. Remove metering jets (if necessary).

9) Remove accelerator pump discharge check ball retainer and check ball. Remove accelerator pump well baffle (if necessary).

10) If equipped, remove secondary (rear) vacuum break diaphragm and bracket. Rotate unit to remove vacuum break rod from slot in diaphragm plunger.

**NOTE** — Vacuum break link is not removed until choke assembly is removed from float bowl.

11) Align a .159" (No. 21) drill on choke cover retaining rivets and drill only enough to remove each rivet head. Drive out remainder of rivets with drift and hammer. Remove 3 retainers, choke cover gasket (hot air type) and choke cover assembly. Remove screw and washer from inside housing. Slide housing out. Remove plastic tube seal from vacuum inlet boss on choke housing of hot air type choke.

**NOTE** — Do not remove baffle plate from under thermostatic coil on choke cover of hot air type choke.

12) If equipped, remove secondary (rear) vacuum break rod from intermediate choke lever. Remove lever screw from end of intermediate choke shaft in choke housing.

13) Remove lever from shaft. Remove intermediate choke shaft from housing by sliding outward. Remove fast idle cam from intermediate choke shaft. Turn float bowl over and remove lower choke lever.

**NOTE** — If housing is to be cleaned, remove cup seal from inside choke housing shaft hole. Remove cup seal from insert to clean float bowl. Do not remove insert.

14) Remove fuel inlet fitting, gasket, check valve/filter assembly and spring. Remove throttle body screws. Separate throttle body from float bowl and remove insulator gasket.

**Throttle Body** — 1) Remove accelerator pump rod from throttle lever by rotating rod until tang on rod aligns with slot in lever.

2) Turn throttle body over and position on a holding fixture with manifold side up. Make 2 parallel cuts in throttle body with a small hacksaw, one on each side of idle mixture needle plug. Cuts should reach down to steel plug, but no more than  $\frac{1}{8}$ " beyond locator points. Distance between saw marks will depend upon size of punch used.

3) Place a flat punch at a point near ends of saw marks. Hold punch at 45° angle and drive it into throttle body until casting breaks away, exposing steel plug.

4) Hold center punch vertically and drive into steel plug. Then hold punch at 45° angle and drive plug out of casting. Repeat process for remaining mixture needle. When removing or installing needles, refer to idle mixture adjustment procedure in Tune-Up Section.

**NOTE** — Hardened steel plug will shatter. It is not necessary to remove plug completely. Remove just enough pieces to allow idle mixture adjusting tool (J-29030) to be used to remove mixture screws and springs. Idle mixture screw head has a "double-D" configuration and can also be removed using a piece of  $\frac{7}{32}$ " copper tubing that has been partially flattened.

## CLEANING &amp; INSPECTION

- Use a regular carburetor cleaning solution. Soak components long enough to thoroughly clean all surfaces and passages of foreign matter.
- Do not soak any components containing rubber, leather or plastic. Particularly do not soak air horn with bleed valve installed, electric choke, idle speed solenoid or control, TPS, thermostatic choke cover and coil, vacuum break diaphragms, pump plunger and other such parts.
- Remove any residue after cleaning by rinsing components in a suitable solvent.
- Blow out all passages with dry compressed air.

**NOTE** — If idle bleed air valve is not removed from carburetors, air horn should be cleaned with a low volatile cleaning solvent. DO NOT place air horn in carburetor cleaner. Damage to "O" rings may occur.

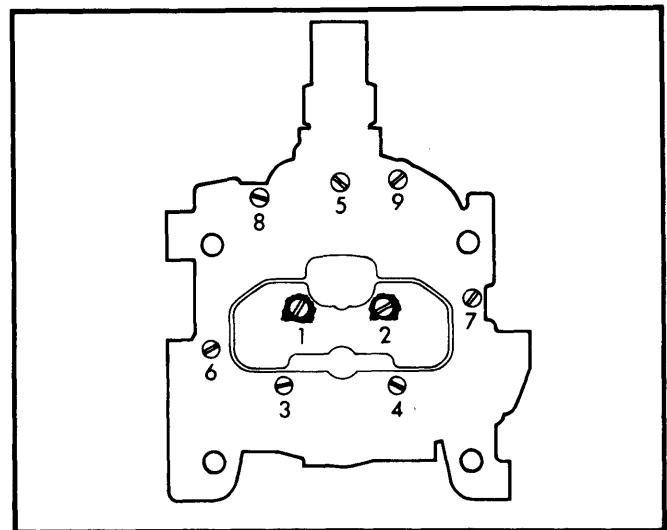

Fig. 13 Air Horn Screw Tightening Sequence

## ROCHESTER E2MC & E2ME 2-BARREL (Cont.)

### REASSEMBLY

**NOTE** — Use new gaskets and seals. Make sure that new gaskets fit correctly and that all holes and slots are punched through and correctly located.

Reassemble carburetor in reverse order of disassembly, noting the following:

1) The intermediate choke shaft lever and fast idle cam are assembled correctly when tang and lever are below fast idle cam.

2) When installing float and retaining pin, make sure open end of float retaining pin faces accelerator pump well.

3) When installing fuel inlet valve, hook pull clip over edge of flat on float arm. Do not hook clip in holes in float arm.

4) When installing mixture control solenoid, make sure pin on end of solenoid aligns with hole in raised boss at bottom of float bowl.

5) Install, adjust and plug all screws to restore tamper-resistant design.

**NOTE** — If choke coil cover was removed, it will be necessary to install service rivet retaining kit. Before installing cover, place fast idle screw on high step of fast idle cam. Align notch in cover with raised boss on housing cover flange and install rivets.

6) Install air horn screws and tighten securely, evenly and in order shown in Fig. 13.

### CARBURETOR ADJUSTMENT SPECIFICATIONS

Application	Float Level Setting	Accelerator Pump		Choke Coil Lever Setting	Choke Rod Setting	Vacuum Break		Auto. Choke Setting	Choke Unloader Setting
		Lever Setting	Hole Setting			Primary Setting	Secondary Setting		
<b>E2MC</b> 17082150	13/32"	TR	TR	.120"	14°	24°	38° <sup>⓪</sup>	TR	35°
<b>E2ME</b> 17082130	3/8"	TR	TR	.120"	20°	27°	.....	TR	38°
17082132	3/8"	TR	TR	.120"	20°	27°	.....	TR	38°
17082138	3/8"	TR	TR	.120"	20°	27°	.....	TR	38°
17082140	3/8"	TR	TR	.120"	20°	27°	.....	TR	38°
17082182	5/16"	TR	TR	.120"	18°	28°	24°	TR	32°
17082184	5/16"	TR	TR	.120"	18°	28°	24°	TR	32°
17082192	5/16"	TR	TR	.120"	18°	28°	24°	TR	32°
17082194	5/16"	TR	TR	.120"	18°	28°	24°	TR	32°
17082196	5/16"	TR	TR	.120"	18°	21°	19°	TR	27°

TR — Tamper Resistant.

⓪ — High Altitude — 40°.