

ROCHESTER MODELS 2SE & E2SE 2-BARREL

CARBURETOR APPLICATION

AMERICAN MOTORS (E2SE & 2SE)

Application	Rochester Carb. No.	
	Man. Trans.	Auto. Trans.
2.5L (151") 4-Cylinder Federal (2SE)		
Eagle	17082380	
Concord & Spirit		
Without A/C	17082383	
With A/C	17082385	
California (E2SE)		
Eagle		
Without A/C	17082388	17082389
With A/C		
Concord & Spirit		
Without A/C	17082386	17082386
With A/C		17082387

GENERAL MOTORS (E2SE)

Application	Rochester Carb. No.	
	Man. Trans.	Auto. Trans.
1.8L (112") 4-Cylinder (Early Production) Federal		
Without A/C	17081601, 607	17081600
With A/C	17081609	
Nationwide		
Without A/C		
With A/C		17081606
1.8L (112") 4-Cylinder (Late Production) Federal		
Without A/C	17082303	
With A/C	17082305	
Nationwide		
Without A/C	17082301	17082300, 304
With A/C		17082300, 304
2.0L (122") 4-Cylinder Nationwide		
	17082631	17082630
2.8L (173") V6 Federal		
Without A/C	17082391	17082390
With A/C	17082491	17082490
Nationwide		
Without A/C	17082317	17082316
With A/C	17082641	17082640
2.8L (173") V6 (High Output) Nationwide		
Without A/C	17082321	17082320
With A/C	17082321	17082642

CARBURETOR IDENTIFICATION

The Rochester 2SE and E2SE carburetor numbers are stamped vertically on the float bowl next to the vacuum tube. If float bowl is replaced, follow manufacturer's instructions contained in service package, so that part number is transferred to new float bowl.

DESCRIPTION

The Rochester Varajet Carburetor models 2SE and E2SE are 2-stage, 2-barrel downdraft carburetors. The primary stage consists of a triple venturi with a 35 mm bore. The secondary stage has a 46 mm bore and is equipped with an air valve with a single tapered metering rod. Both are equipped with integral, electronically-activated chokes, a choke vacuum break

diaphragm and an idle speed solenoid. The 2SE model is used on American Motors Federal models.

The E2SE model is used by General Motors with the Computer Command Control system. The E2SE model is used by American Motors with the C-4 or Computerized Emission Control (CEC) system. The E2SE model is equipped with an electrically operated mixture control solenoid. The mixture control solenoid is mounted on the air horn and extends into fuel bowl. Fuel metering is controlled by the mixture control solenoid plunger opening and closing the fuel passage to the main metering jet.

When the plunger is in the down position (lean), fuel metering is controlled by a factory-adjusted lean mixture screw located in the float bowl. When plunger is in the up position (rich), additional fuel is metered to the main fuel well through the factory-adjusted rich mixture screw located at the end of the fuel supply channel in the float bowl.

Air is also metered by the plunger and is further metered by an idle air bleed screw (adjustable on American Motors, fixed on General Motors). The system constantly monitors exhaust gas oxygen content and other engine conditions to adjust air/fuel mixture accordingly.

All General Motors models are equipped with a Throttle Position Sensor (TPS) to electrically signal the ECM of throttle position. The ECM then "holds" the last known air/fuel mixture ratio or activates the mixture control solenoid to adjust the mixture as needed.

On American Motors models with A/C, an Idle Speed Solenoid (ISS) is used to maintain idle speed during A/C operation. All General Motors models are equipped with an Idle Speed Control (ISC) motor. The ISC is controlled by the ECM to maintain idle speed under all operating conditions.

NOTE — No attempt should be made to set curb idle speed with the Idle Speed Solenoid or Idle Speed Control motor.

All General Motors carburetors are equipped with a temperature regulated pump system with a thermostatically controlled by-pass valve. The by-pass valve is permanently pressed into the air horn. The by-pass valve contains a bi-metal snap disc that opens and closes the valve according to engine temperature. When closed (cold engine), pump delivers fuel to primary bore at full pump capacity. When open (warm engine), part of the fuel is returned to the fuel bowl. The by-pass valve is an integral part of the air horn and is not serviceable.

All carburetors are equipped with tamper-resistant features: factory-adjusted rich mixture screws (except General Motors), factory-adjusted lean mixture screws, riveted choke coil housing and hardened steel pump lever. All models are also equipped with idle mixture screw plugs.

CAUTION — NO ATTEMPT should be made to adjust screws except when required by a Computer Command Control System performance check, major overhaul, or replacement of the air horn, float bowl or throttle body.

ADJUSTMENT

HOT (SLOW) IDLE RPM

See appropriate article in TUNE-UP SERVICE PROCEDURES.

COLD (FAST) IDLE RPM

See appropriate article in TUNE-UP SERVICE PROCEDURES.

ROCHESTER MODELS 2SE & E2SE 2-BARREL (Cont.)

IDLE MIXTURE

See appropriate article in TUNE-UP SERVICE PROCEDURES.

IDLE AIR BLEED VALVE
(AMERICAN MOTORS E2SE ONLY)

See appropriate article in TUNE-UP SERVICE PROCEDURES.

IDLE SPEED CONTROL

See appropriate article in TUNE-UP SERVICE PROCEDURES.

▶ ANGLE GAUGE ADJUSTMENT TOOL

Manufacturer recommends that some carburetor adjustments be performed using a choke valve angle gauge (Kent-Moore tool no. J-26701). While preparations and actual adjustments may vary with each individual adjustment, the procedure for using the angle gauge to check the choke valve angle remains the same. Use the following procedure to perform adjustments requiring the use of the choke angle gauge. See Fig. 1.

- 1) Rotate degree scale on angle gauge so that 0° mark is opposite pointer.
- 2) With choke valve closed, place angle gauge magnet squarely on choke valve.
- 3) Rotate leveling bubble on angle gauge until it is centered.
- 4) Rotate degree scale until specified degree mark is opposite pointer.
- 5) Now perform individual adjustment preparations as outlined in the following carburetor adjustments requiring angle gauge. If bubble is centered, adjustment is correct. If not, adjust carburetor as outlined.

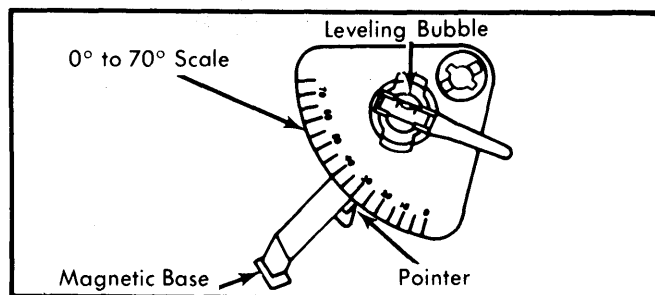

Fig. 1 Choke Valve Angle Gauge

FLOAT LEVEL

- 1) Remove air horn and gasket from float bowl. Hold float retainer firmly down while pushing float down against needle. See Fig. 2.
- 2) Position a "T" scale over large toe of float at point furthest away from float hinge pin. Measure distance from float bowl casting to float.

NOTE — A new set of external float gauges (J9789-135) are available for 2SE and E2SE carburetors. By selecting proper gauge for specific carburetor being checked, a simple "On Car" check can be made without removing air horn from float bowl. Just remove vent stack and air horn screw and insert gauge in air horn screw hole. Let it float freely.

- 3) To adjust, remove float and bend float arm. Check to make sure float is correctly aligned after adjustment.

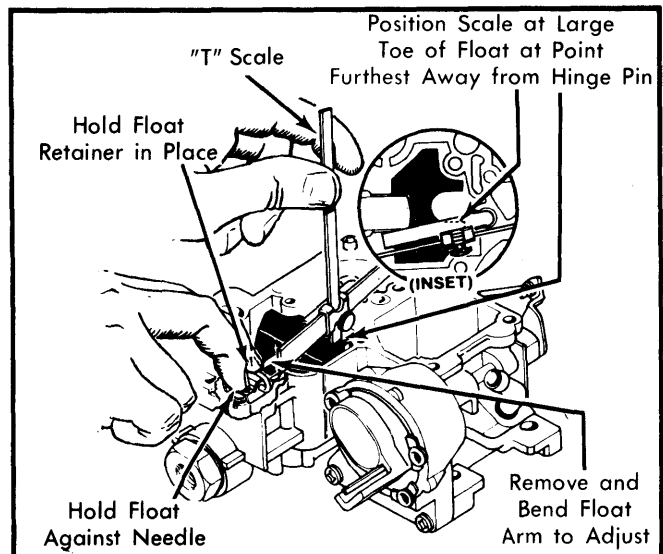

Fig. 2 Adjusting Float Level

ACCELERATOR PUMP

NOTE — If carburetor has a clip retaining pump rod in pump lever, no adjustment is required. If connection is "clipless", pump adjustment should not be changed from original factory setting. See Fig. 3. Adjustment should only be made if specified setting is changed. Pump lever is manufactured from hardened steel, making it difficult to bend. Pump arm should not be removed to make adjustment unless absolutely necessary.

- 1) Close throttle valves completely. Make sure fast idle speed screw is off fast idle cam. See Fig. 3.
- 2) Using a "T" scale, measure accelerator pump specified distance from cast surface of air horn to top of pump stem.
- 3) To adjust, remove pump lever screw and washer. Remove pump lever by rotating lever and removing from pump rod. Secure lever in a vise and bend end of lever at small segment.

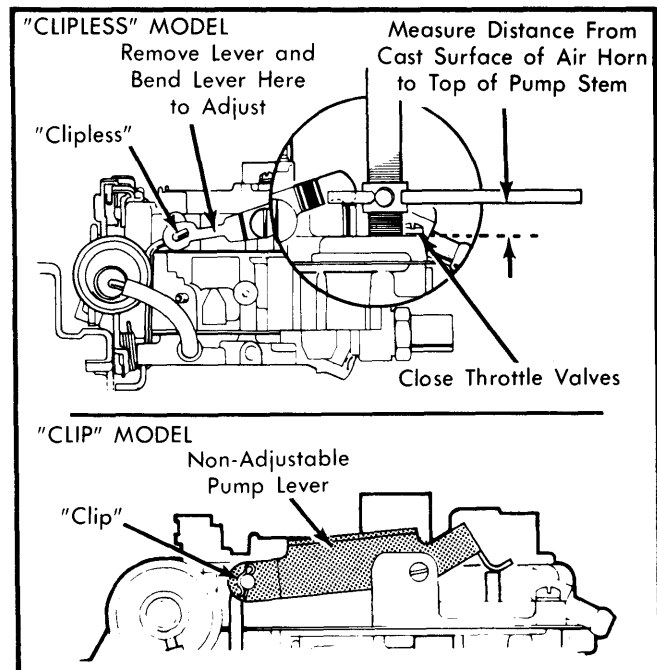

Fig. 3 Adjusting Accelerator Pump

ROCHESTER MODELS 2SE & E2SE 2-BARREL (Cont.)

4) Install pump lever, washer and retaining screw. Recheck pump adjustment, and when correct, tighten retaining screw. Open and close throttle and check for free linkage movement and pump lever alignment.

CHOKE COIL LEVER

NOTE — Do not remove rivets and retainers holding choke cover and coil assembly in place unless necessary to check choke coil lever adjustment. If rivets and cover are removed, a new rivet service kit must be installed.

1) Remove rivets and choke thermostatic cover from choke housing. Place fast idle screw on high step of fast idle cam. See Fig. 4.

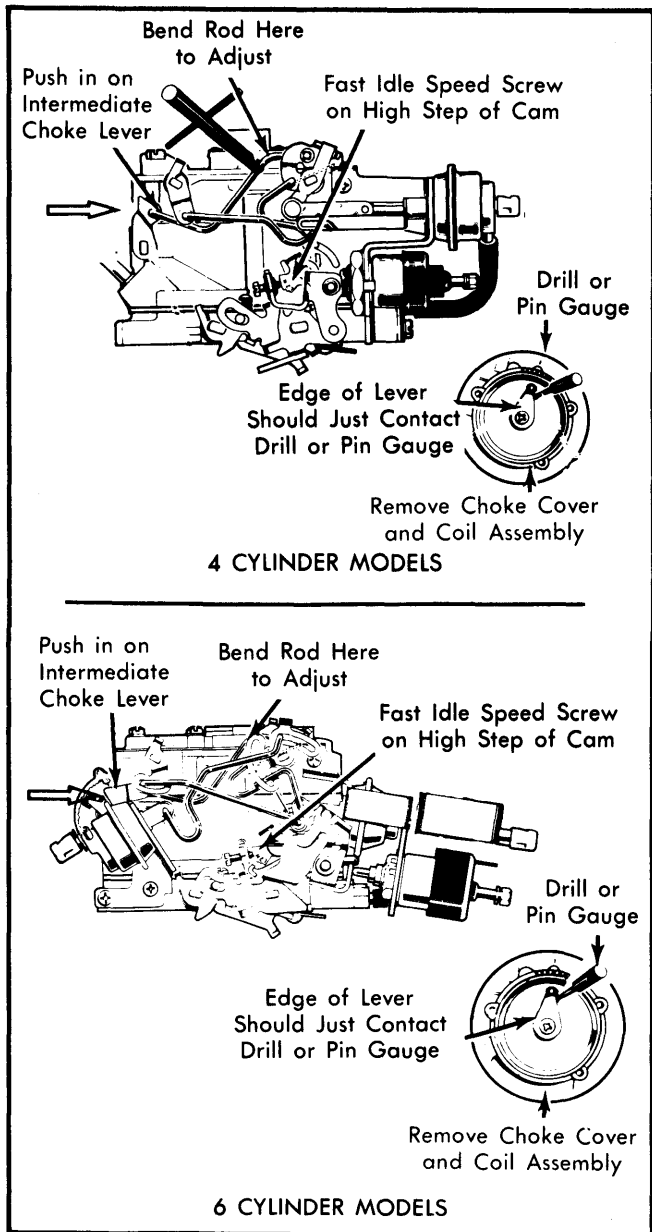

Fig. 4 Adjusting Choke Coil Lever

2) Push in on intermediate choke lever until choke valve is fully closed.

3) Insert a specified drill or pin gauge in hole provided in choke housing. Choke lever inside housing should just touch drill or pin gauge.

4) To adjust, bend intermediate choke rod at point shown in illustration. Reinstall choke cover and adjust.

CHOKE ROD (FAST IDLE CAM)

NOTE — Choke coil lever adjustment must be correct and fast idle must be adjusted before proceeding. This adjustment makes use of choke angle gauge. See instructions at beginning of Adjustments.

1) Place fast idle speed screw on second step of fast idle cam against shoulder of highest step. See Fig. 5.

2) Close choke valve by pushing on intermediate choke lever. Push vacuum break lever toward open choke until lever is against rear tang on choke lever.

3) Bubble on choke angle gauge should be centered with specified degree mark opposite pointer.

4) To adjust, bend fast idle cam rod at point shown in illustration until bubble of choke valve angle gauge is centered.

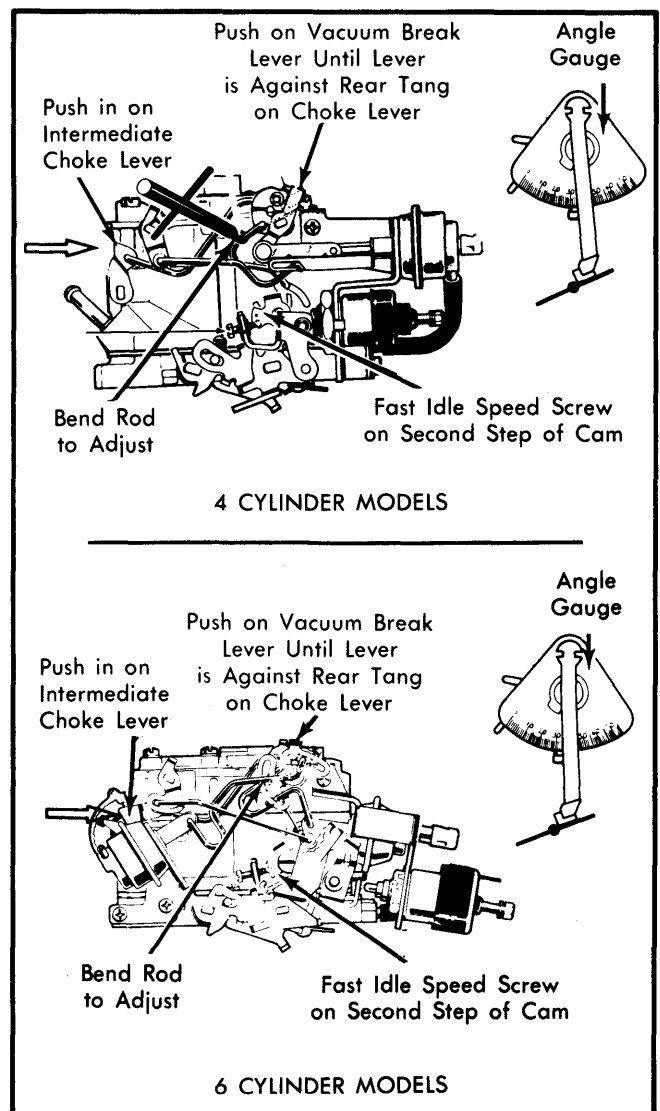

Fig. 5 Adjusting Choke Rod (Fast Idle Cam)

ROCHESTER MODELS 2SE & E2SE 2-BARREL (Cont.)

AIR VALVE ROD

NOTE — This adjustment is made by using the choke valve angle gauge. See procedure at beginning of Adjustments.

1) Using an outside vacuum source of at least 15 in. Hg, seat primary choke vacuum break diaphragm. Close air valve, mount and adjust angle gauge. See Fig. 6.

NOTE — Plug end cover on 4-cylinder models, using tape or accelerator pump plunger cup. Cup must be removed after adjustment is completed.

2) Apply light opening pressure to air valve shaft. Set to specified angle by bending air valve rod at a point near its connection to primary vacuum break (models equipped with primary vacuum break only) or at a point near its connection to air valve lever (models equipped with primary and secondary vacuum breaks).

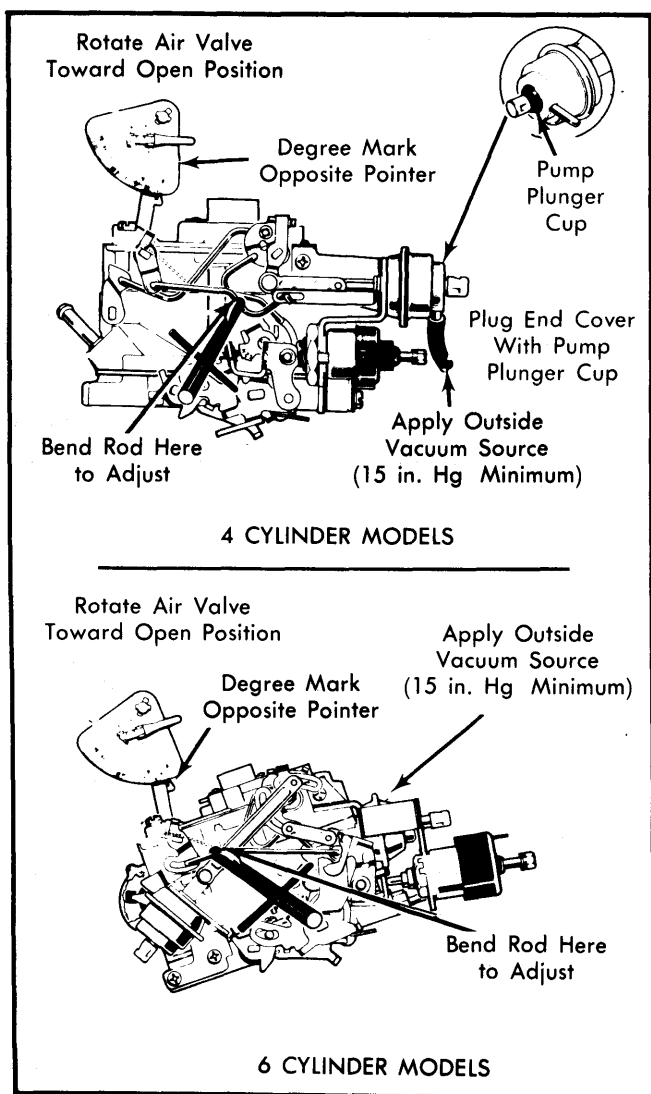

Fig. 6 Adjusting Air Valve Rod

PRIMARY VACUUM BREAK

NOTE — This adjustment is performed using the choke valve angle gauge, see procedure at beginning of Adjustments.

1) Remove primary choke vacuum break from carburetor. Place vacuum break bracket in vise and carefully grind off adjustment screw cap. Reinstall vacuum break. Using an outside vacuum source, seat choke vacuum break diaphragm. See Fig. 7. Air valve rod should not prevent seating of vacuum break diaphragm.

NOTE — Plug end cover on 4-cylinder models, using tape or accelerator pump plunger cup. Cup must be removed after adjustment is completed. Be sure plunger bucking spring is compressed and seated (plunger fully extended), if so equipped.

2) Close choke valve by pushing on intermediate choke lever. Bubble on choke valve angle gauge should be centered with specified degree mark opposite pointer.

3) To adjust, use a $\frac{1}{8}$ " hex wrench to turn screw in rear cover until bubble is centered. Remove cup after adjustment and apply RTV silicone sealant over screw head to seal setting.

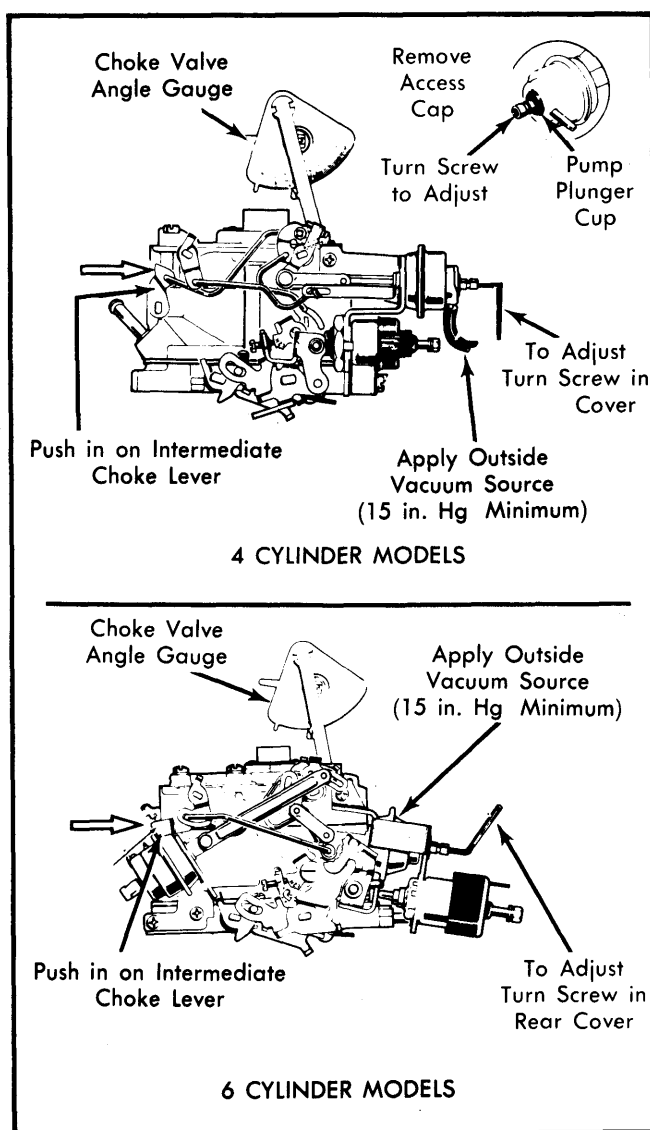

Fig. 7 Primary Vacuum Break Adjustment

AUTOMATIC CHOKE

NOTE — Choke coil cover is retained on housing with rivets to prevent tampering with factory adjustment. If necessary to

ROCHESTER MODELS 2SE & E2SE 2-BARREL (Cont.)

remove cover, refer to *Disassembly and Reassembly procedures in this Section.*

CHOKE UNLOADER

NOTE — This adjustment is performed using the choke valve angle gauge, see procedure at beginning of adjustments.

- 1) Automatic choke should be to specified setting. Do not adjust setting unless carburetor is to be overhauled or unless choke coil lever adjustment is necessary. Hold primary throttle valve wide open. See Fig. 8.
- 2) If engine is warm, close choke valve by pushing in on intermediate choke lever. Hold in position with rubber band.
- 3) Place vacuum break lever against rear tang on choke lever (toward open choke). To adjust, bend tang on throttle lever until bubble is centered.
- 4) Remove gauge and reinstall choke cover and coil assembly if previously removed. Install service rivet and retainer kit.

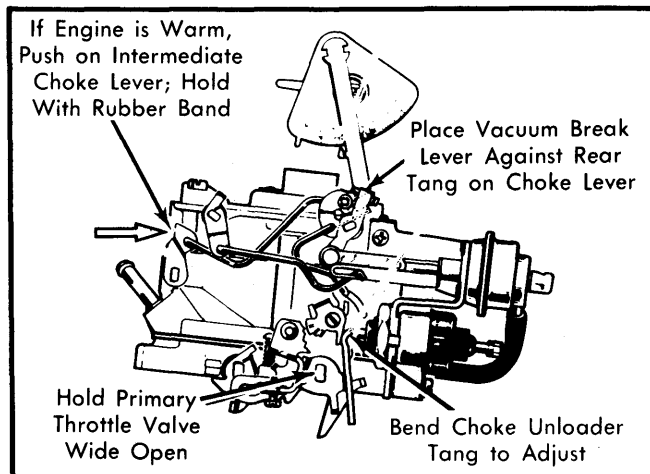

Fig. 8 Choke Unloader Adjustment

SECONDARY VACUUM BREAK

NOTE — This adjustment is made using the choke valve angle gauge, see procedure at beginning of Adjustments.

- 1) Remove secondary choke vacuum break from carburetor. Place vacuum break bracket in vise and carefully grind off adjustment screw cap. Reinstall vacuum break. Using an outside vacuum source, seat secondary choke vacuum break diaphragm. See Fig. 9.

NOTE — Plug end cover using tape or accelerator pump plunger cup. Cup or tape must be removed after adjustment is completed.

- 2) Close choke valve by pushing in on intermediate choke lever. Make sure bucking spring on diaphragm plunger (if equipped) is fully compressed and seated.
- 3) Bubble on choke valve angle gauge should be centered with specified degree mark opposite pointer.
- 4) To adjust, use $\frac{1}{8}$ " hex wrench to turn screw in rear cover until bubble is centered. Remove cup or tape after adjustment. Apply RTV silicone sealant over screw head to seal setting.

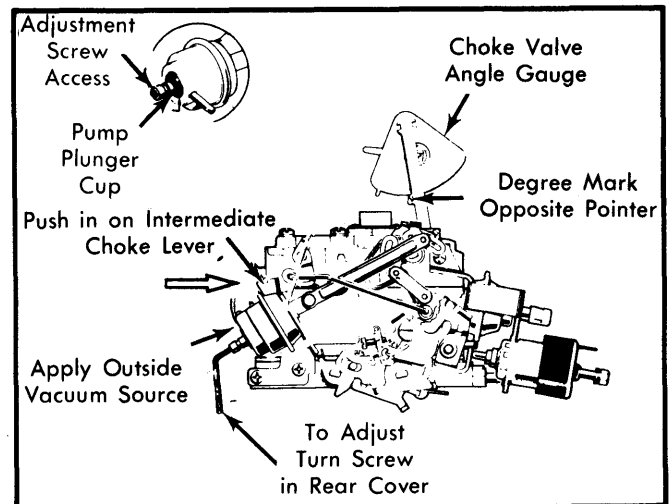

Fig. 9 Secondary Vacuum Break Adjustment

SECONDARY LOCKOUT

- 1) Hold choke valve wide open by pulling out (counterclockwise) on intermediate choke lever. See Fig. 10.
- 2) Open throttle lever until end of secondary actuating lever is opposite toe of lockout lever.
- 3) Measure specified clearance between end of actuating lever and toe of lockout lever. Measurement can be checked using a drill or pin gauge of specified size.
- 4) To adjust, bend lockout lever tang contacting fast idle cam.

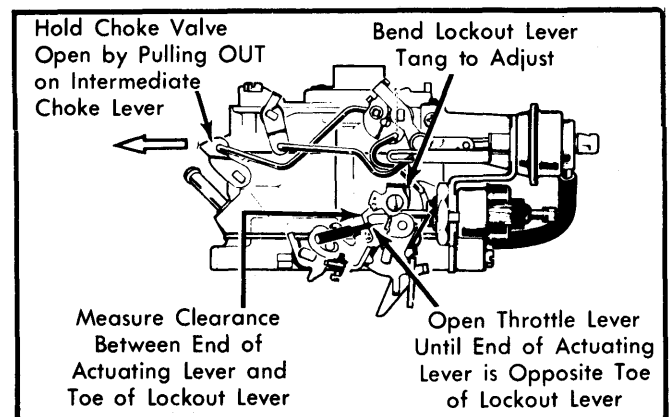

Fig. 10 Adjusting Secondary Throttle Lockout

AIR VALVE SPRING (GENERAL MOTORS ONLY)

- 1) Using an Allen wrench, loosen air valve lock screw. Using a screwdriver, turn tension adjusting screw clockwise until air valve opens part way. See Fig. 11.
- 2) Turn tension adjusting screw counterclockwise until air valve just closes. Turn adjusting screw additional specified turns (counterclockwise).
- 3) After adjustment, coat air valve shaft pin and closing spring contact areas with lithium base grease.

ROCHESTER MODELS 2SE & E2SE 2-BARREL (Cont.)

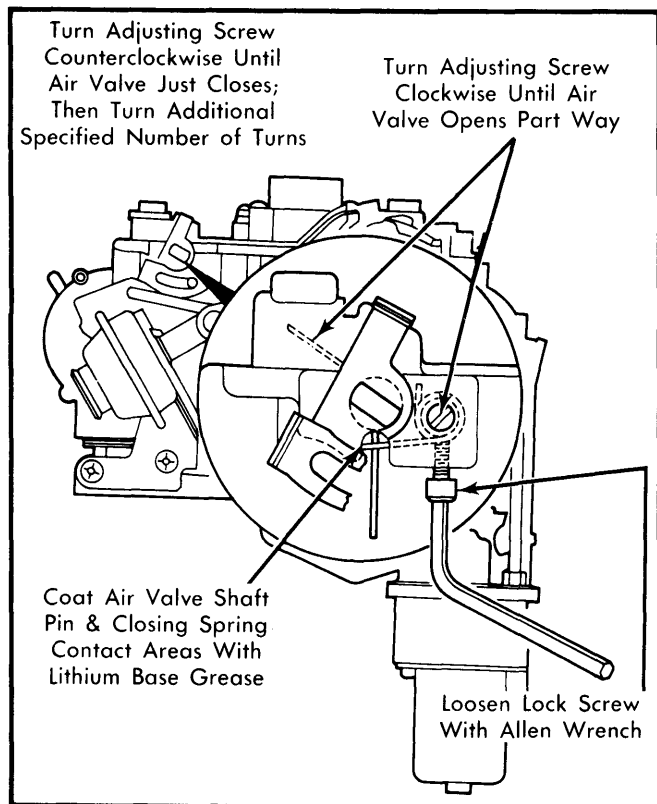

Fig. 11 Air Valve Spring Adjustment
(General Motors Only)

FAST IDLE BENCH ADJUSTMENT

Place fast idle screw on highest step of fast idle cam. See Fig. 12. Turn fast idle screw in or out to just contact cam. Then turn screw in specified number of turns, as shown on emission control label.

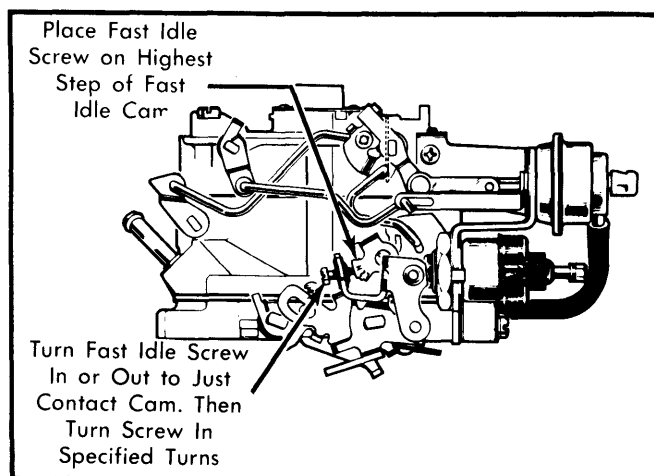

Fig. 12 Fast Idle Bench Adjustment

OVERHAUL

DISASSEMBLY

NOTE — Before disassembling carburetor, mount unit in a suitable holding fixture to prevent damage to throttle valves or linkage.

Air Horn — 1) Bend back tabs on idle speed solenoid lock washer. Remove large solenoid retaining nut. Care must be taken when loosening nut to avoid damaging linkage, solenoid bracket, throttle lever or vacuum break. Remove solenoid and washer from bracket.

NOTE — On models with Idle Speed Control, remove control bracket (to vacuum break) attaching screws. Remove control and bracket as an assembly.

2) On 2SE models (NOT USING a clip to secure the accelerator pump rod), remove pump lever retaining screw from air horn. Rotate pump lever to remove from pump rod. On E2SE models (using a clip to secure pump rod), remove clip and remove pump rod from hole in pump lever.

CAUTION — DO NOT remove pump lever retaining screw from E2SE models using clip as pump rod retainer. Pump lever and washer must not be removed from air horn assembly on these models.

3) Remove hose from primary vacuum break assembly. Remove bracket attaching screws. Rotate vacuum break and bracket assembly to disengage vacuum break link and air valve rod from slot in air valve lever.

4) If equipped, remove secondary vacuum break attaching screws. Rotate bracket assembly to remove vacuum break link from vacuum break lever slot.

5) Remove and discard retaining clip from intermediate choke rod at choke lever. Use a new retaining clip during reassembly. Remove choke rod and plastic bushing from choke lever. Bushing may be reused.

6) If equipped, remove hot idle compensator valve screws. Remove valve and seal from air horn. Discard seal. Valve removal is necessary to gain access to short air horn-to-bowl attaching screw.

7) On E2SE models, remove 3 mixture control solenoid screws and remove mixture control solenoid using a light twisting motion. Remove and discard solenoid gasket, plunger seal and plunger seal retainer.

8) Remove all air horn-to-float bowl screws and lock washers. Remove vent and screen assembly. Rotate fast idle cam up as far as possible. Rotate air horn and tilt to disengage fast idle

NOTE — If pump plunger comes out of float bowl with air horn removal, remove pump plunger from air horn. Air horn gasket should remain on float bowl. Do not remove fast idle cam screw and cam from float bowl. These parts must remain permanently in place as installed by manufacturer. Service replacement float bowl will include fast idle cam screw and cam.

9) Disconnect fast idle cam rod from choke lever by aligning tang on rod with slot in lever. Lift off air horn assembly.

10) If equipped, remove TPS plunger by pushing through seal in air horn. Remove seal retainer and seal. Remove accelerator pump plunger seal from air horn.

NOTE — Use fingers only (no tools) when removing plunger to prevent damage to sealing surface. Use care in removing plunger seal retainer and plunger stem seal retainer to prevent damage to air horn. Discard seals and retainers.

11) No further disassembly of air horn is required. Air valve and choke valve attaching screws are staked in place and not

ROCHESTER MODELS 2SE & E2SE 2-BARREL (Cont.)

removable. New service replacement air horn assembly includes secondary metering rod and air valve assemblies with preset factory adjustments.

NOTE — No attempt should be made to change air valve settings.

Float Bowl — 1) Remove air horn gasket. Remove pump plunger and pump spring from pump well. Remove plastic filler block from float valve.

2) Remove float assembly and float valve, pulling up on retaining pin. Remove float needle seat, gasket and extended metering jet from float bowl. Use suitable tool (J-22769) or screwdriver that fully fits slot in top of jet.

NOTE — Do not remove or adjust small calibration screw located deep inside metering jet. Adjustment should be made only if required by a Computer Command Control System performance check.

3) On E2SE models, push up from bottom on electrical connector and remove TPS and connector from float bowl. Remove spring from bottom of TPS well in bowl. On 2SE models, press down on power piston stem and allow it to snap up. Repeat this until plastic retainer is dislodged and remove power piston and metering rod assembly.

4) Remove spring from power piston bore. If necessary to remove metering rod from hanger, compress spring on metering rod and align groove on rod with slot in holder. Care must be taken not to damage tip of metering rod.

5) Remove main metering jet using a screwdriver that fits tight in groove. Using a small slide hammer, remove plastic retainer holding pump discharge spring and check ball in place in float bowl. Discard retainer.

6) To remove choke cover and coil assembly, align a .159" (No. 21) drill on choke cover retaining rivets. Drill only enough to remove rivet heads. Remove rivets, choke cover and coil assembly. Remove screw from end of intermediate choke shaft in choke housing. Remove choke coil lever from shaft.

7) Slide intermediate choke shaft out of float bowl. Remove choke housing screws and remove choke housing. Remove fuel inlet nut, gasket, check valve/filter and spring.

8) Remove 4 screws securing throttle body to float bowl. Remove throttle body. Remove throttle body insulator gasket.

Throttle Body — 1) Hold throttle valves wide open. Disengage pump rod from throttle lever by rotating rod until tang on rod aligns with slot in lever.

2) Remove curb idle and fast idle speed screws and springs if necessary. Further disassembly of throttle body is not required. Throttle valve screws are permanently staked in position.

NOTE — Do not remove idle mixture screw plug unless it is necessary to replace mixture screw or cleaning and air pressure fail to clean idle mixture passages. If necessary to remove, proceed as follows:

3) Invert throttle body and position on a holding fixture with manifold side up. Using a small hacksaw, make 2 small cuts, one on either side of mixture screw plug location. Position a small flat punch on throttle body between cuts.

4) Drive punch down and break out portion of throttle body between the 2 cuts. Hold punch at a 45° angle and drive out hardened steel plug.

NOTE — Plug will shatter when struck. Remove loose pieces to allow the use of adjusting tool (J-28706) or thin walled deep 3/16" socket to remove adjusting screw and spring.

5) Turn mixture screw in carefully, counting turns needed to seat screw. Record number to be used in reassembly, then remove mixture screw.

CLEANING & INSPECTION

- Do not soak any components containing rubber, leather or plastic. Definitely do not soak idle speed solenoid or control, mixture control solenoid, throttle position sensor, electric choke, diaphragms, pump plunger and plastic filler block. Plastic bushings will withstand normal cleaning.
- Use a regular carburetor cleaning solution. Soak components long enough to thoroughly clean all surfaces and passages of foreign matter.
- Remove any residue after cleaning by rinsing components in a suitable solvent.
- Blow out all passages with dry compressed air.
- Test mixture control solenoid for sticking, binding or leaking. Connect jumper wire between battery positive terminal and right (positive) solenoid terminal. Connect another jumper wire between battery negative terminal and left (negative) solenoid terminal. Remove rubber seal and retainer from solenoid stem and attach hand vacuum pump and gauge. See Fig. 13. Apply 25 in. Hg of vacuum. Time leak-down rate from 20 in. Hg to 15 in. Hg. If vacuum drops more than 5" in 5 seconds, replace mixture control solenoid. Remove jumper wires. Apply 15 in. Hg of vacuum. Vacuum should drop to zero in less than 1 second. If not, replace solenoid.

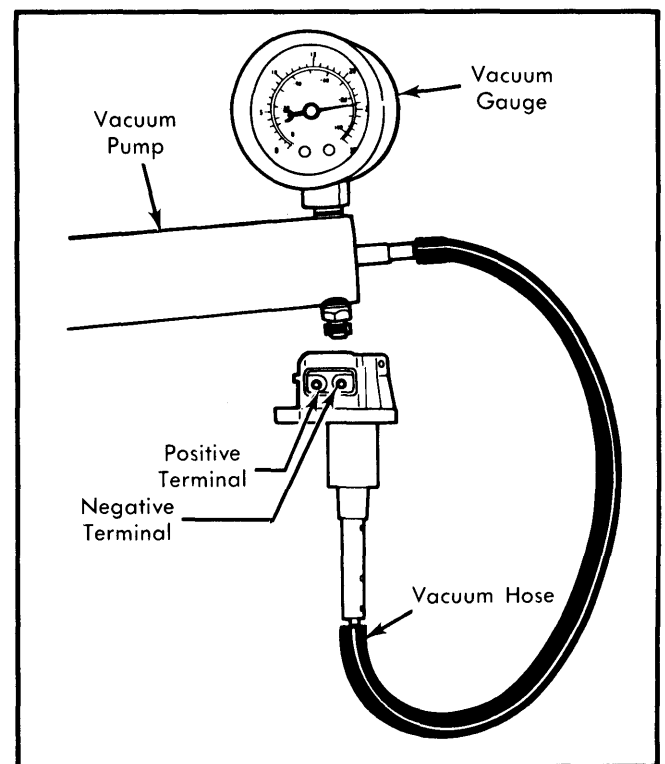

Fig. 13 Testing Mixture Control Solenoid (Disassembled From Carburetor)

1982 Rochester Carburetors

ROCHESTER MODELS 2SE & E2SE 2-BARREL (Cont.)

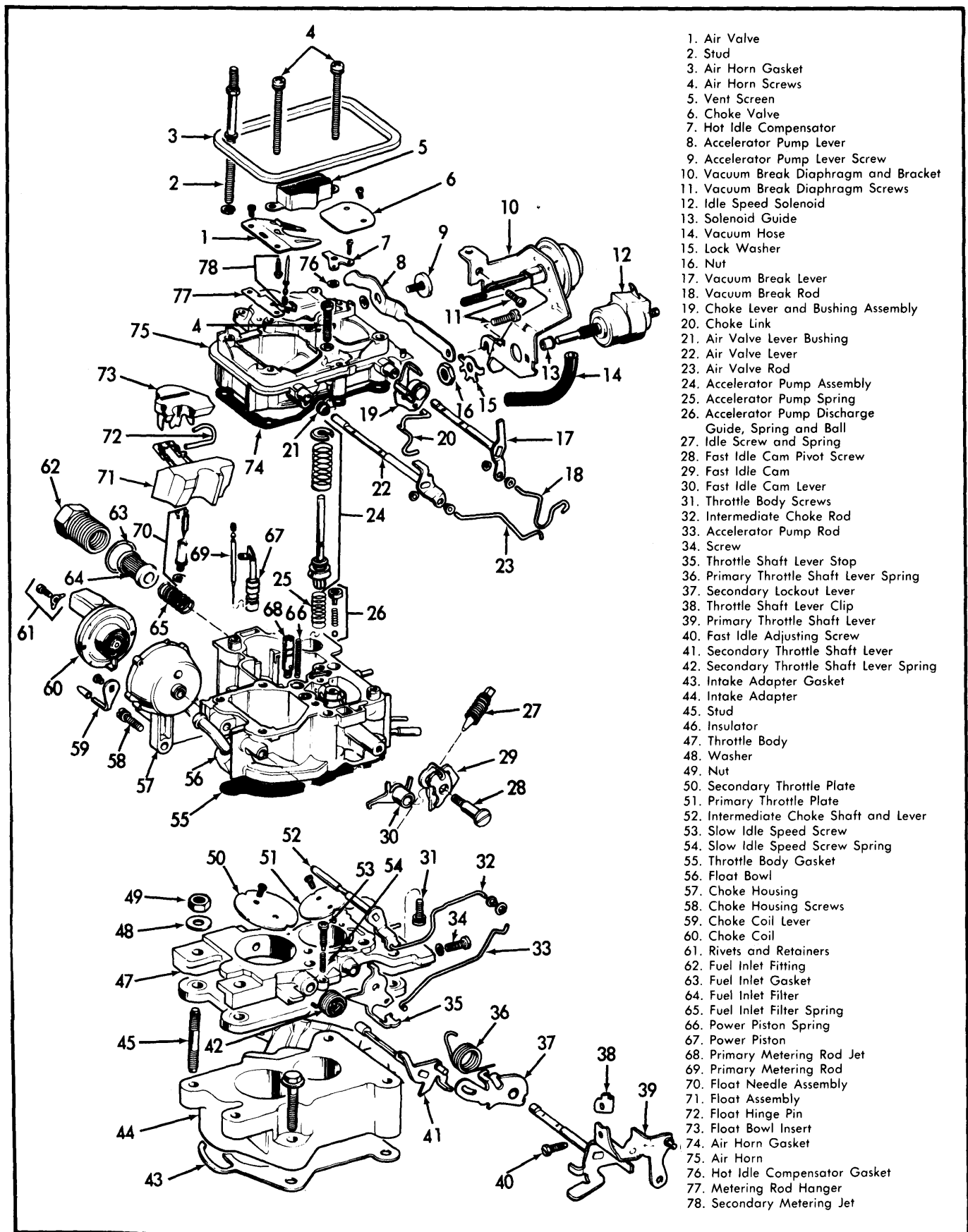

Fig. 14 Exploded View of Rochester 2SE 2-Barrel Carburetor

ROCHESTER MODELS 2SE & E2SE 2-BARREL (Cont.)

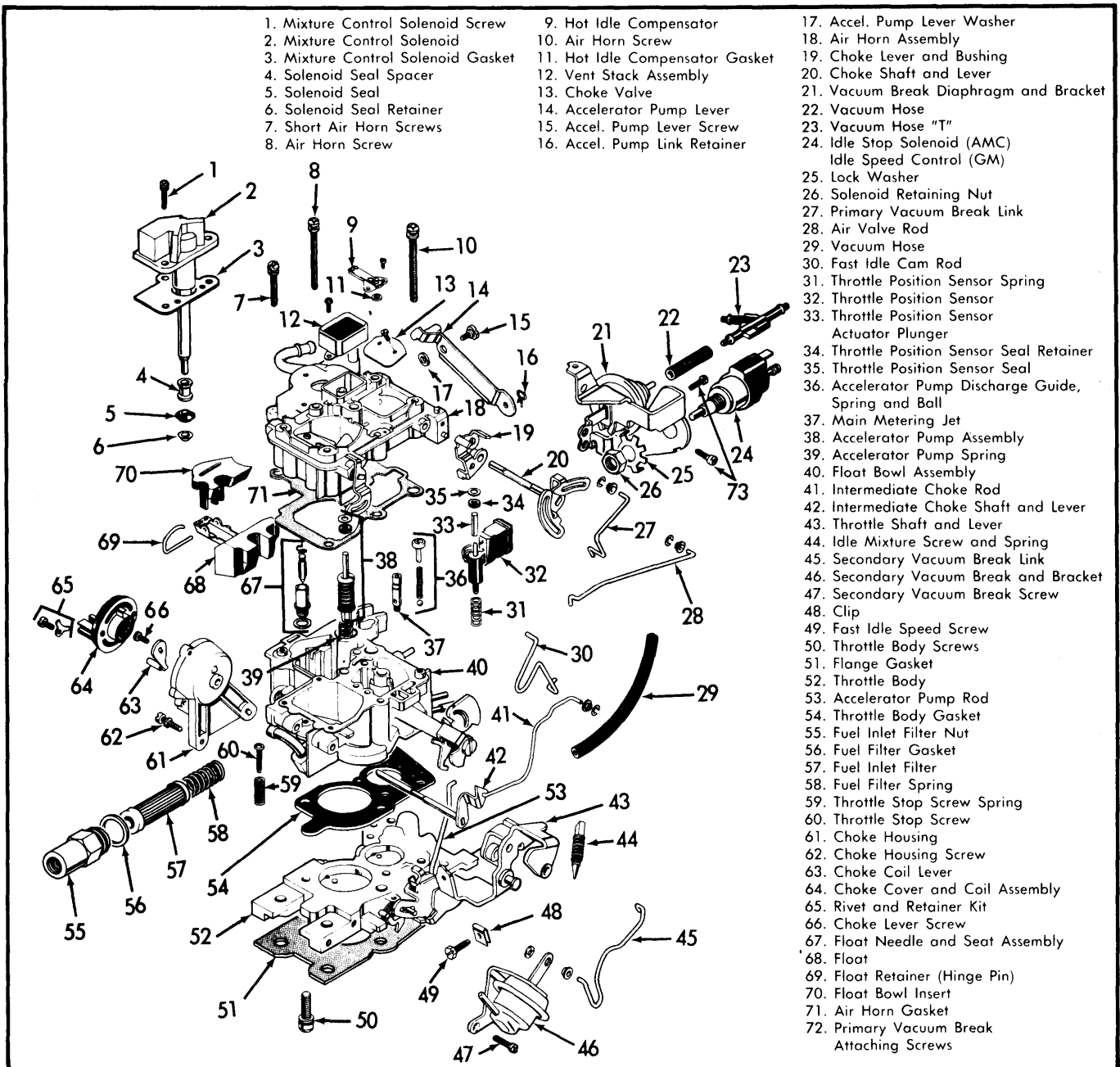

Fig. 15 Exploded View of Rochester E2SE 2-Barrel Carburetor

REASSEMBLY

NOTE — Use new gaskets and seals. Make sure new gaskets fit correctly and all holes are punched through and properly located.

To reassemble carburetor, reverse disassembly procedure and note the following:

1) Install fuel inlet needle pull clip over edge of flat on float arm facing float. Do not hook clip in holes in float arm.

2) After throttle body is installed on float bowl, make sure secondary lockout tang is in correct position to engage secondary lockout lever.

3) Install new accelerator pump discharge check ball and spring plastic retainer. Insert end of retainer in spring and place in position in float bowl. Lightly tap retainer into position until it is flush in float bowl.

4) Make sure holes in fuel filter face toward fuel inlet fitting when filter is installed.

5) Some linkage retaining clips are dished. Make sure portion of clip that bends outward is toward end of rod. Make sure clip makes full contact with rod.

6) Place fast idle screw on high step of fast idle cam. Install choke coil cover, aligning notch in cover with raised boss on housing cover flange.

ROCHESTER MODELS 2SE & E2SE 2-BARREL (Cont.)

NOTE — If choke cover and coil assembly was removed from housing, a service rivet kit must be installed to restore tamper-resistant feature.

CAUTION — On E2SE models, be sure coil pick-up lever is located inside choke coil tang. Also, on electric chokes, the ground contact is provided by a metal plate at rear of choke cover assembly. Do not install a choke cover gasket between electric choke assembly and choke housing.

7) Install air horn screws, noting location and type of screw for correct installation. Tighten screws evenly, securely and in proper sequence. See Fig. 16.

8) On E2SE models, install mixture control solenoid seal on solenoid stem. Using a $\frac{3}{16}$ " socket and hammer, lightly tap retainer in place, on stem, leaving a slight clearance between retainer and seal. Apply silicone grease to seal before installation of solenoid.

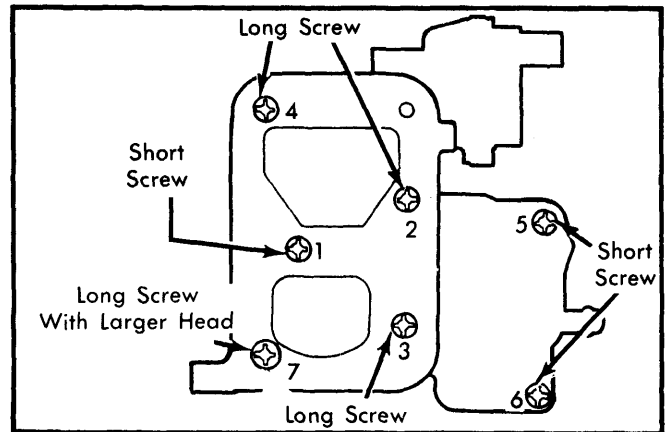

Fig. 16 Air Horn Screw Location and Tightening Sequence

CARBURETOR ADJUSTMENT SPECIFICATIONS

Application	Float Level Setting	Accel. Pump Setting	Choke Coil Lever Setting	Choke Rod Setting	Air Valve Rod Setting	Vacuum Break		Air Valve Spring [ⓐ]	Choke Unloader Setting	Secondary Lockout Setting
						Primary Setting	Secondary Setting			
American Motors										
2SE										
17082380	1/8"	1/8"	.085"	18°	2° [ⓑ]	21°	34°	.065"
17082383	7/32"	1/8"	.085"	18°	2° [ⓑ]	21°	34°	.065"
17082385	7/32"	1/8"	.085"	18°	2° [ⓑ]	21°	34°	.065"
E2SE										
17082386	1/4"	1/8"	.065"	18°	2° [ⓑ]	19°	34°	.065"
17082387	1/4"	1/8"	.085"	18°	2° [ⓑ]	19°	34°	.065"
17082388	1/4"	1/8"	.085"	18°	2° [ⓑ]	19°	34°	.065"
17082389	1/4"	1/8"	.085"	18°	2° [ⓑ]	19°	34°	.065"
General Motors										
E2SE										
17081600	5/16"	TR	.085"	18°	1°	23°	27°	1/2	35°	.026"
17081601	5/16"	TR	.085"	18°	1°	21°	27°	1/2	35°	.026"
17081606	5/16"	TR	.085"	18°	1°	23°	27°	1/2	35°	.026"
17081607	5/16"	TR	.085"	18°	1°	21°	27°	1/2	35°	.026"
17081609	5/16"	TR	.085"	18°	1°	21°	27°	1/2	35°	.026"
17082300	5/16"	TR	.085"	18°	1°	23°	27°	1/2	35°	.026"
17082301	5/16"	TR	.085"	18°	1°	21°	27°	1/2	35°	.026"
17082303	5/16"	TR	.085"	18°	1°	21°	27°	1/2	35°	.026"
17082304	5/16"	TR	.085"	18°	1°	23°	27°	1/2	35°	.026"
17082305	5/16"	TR	.085"	18°	1°	21°	27°	1/2	35°	.026"
17082316	1/4"	TR	.085"	17°	1°	26°	34°	1	35°	.026"
17082317	1/4"	TR	.085"	17°	1°	29°	35°	1	35°	.026"
17082320	1/4"	TR	.085"	25°	1°	30°	35°	1	33°	.026"
17082321	1/4"	TR	.085"	25°	1°	29°	35°	1	33°	.026"
17082390	13/32"	TR	.085"	17°	1°	26°	34°	1	35°	.026"
17082391	13/32"	TR	.085"	25°	1°	29°	35°	1	35°	.026"
17082490	13/32"	TR	.085"	17°	1°	26°	34°	1	35°	.026"
17082491	13/32"	TR	.085"	25°	1°	29°	35°	1	35°	.026"
17082630	5/16"	TR	.085"	18°	1°	23°	27°	1/2	35°	.026"
17082631	5/16"	TR	.085"	18°	1°	23°	25°	1/2	35°	.026"
17082640	1/4"	TR	.085"	17°	1°	26°	34°	1	35°	.026"
17082641	1/4"	TR	.085"	17°	1°	29°	35°	1	35°	.026"
17082642	1/4"	TR	.085"	25°	1°	30°	35°	1	33°	.026"

TR — Tamper-Resistant.

ⓐ — Number of Turns.

ⓑ — Maximum Degree Setting.