

## HOLLEY MODEL 1945 & 1946-1V SINGLE BARREL

### CARBURETOR APPLICATION

#### CHRYSLER CORP. (1945)

Application	Chrysler Corp. Carb. No.	
	Man. Trans.	Auto. Trans.
3.7L (225") 6-Cylinder		
Nationwide .....		R-9627A
High Altitude .....		R-9628A

#### FORD MOTOR CO. (1946-1V)

Application	Ford Motor Co. Carb. No.	
	Man. Trans.	Auto. Trans.
3.3L (200") 6-Cylinder		
Nationwide		
Without A/C .....		E2BE-9510-BA
With A/C .....		E2BE-9510-CA
High Altitude		
With A/C .....		E2BE-9510-SA
With A/C .....		E2BE-9510-TA

### CARBURETOR IDENTIFICATION

Part number is stamped in float bowl body or on tag attached to carburetor.

### DESCRIPTION

The Holley model 1945 and 1946-1V carburetors are single-barrel downdraft designs. The carburetor consists of 3 main sub-assemblies: air horn, main body and throttle body. Air horn houses choke valve, accelerator pump system, vacuum controlled power enrichment valve piston assembly, choke bimetal assembly and fuel bowl vent assembly.

Main body houses fuel inlet system (float assembly and needle valve), main metering jet, power enrichment valve assembly, accelerator pump check ball and weight and hot idle compensator (if equipped). Throttle body houses throttle valve, linkage and tamper-proof idle mixture adjusting needle.

The 1945 and 1946-1V carburetors consist of 4 main fuel metering systems: idle system provides air/fuel mixture for smooth idle and a transfer system for low speed operation, main metering system provides an economical air/fuel mixture for normal operation, accelerator system provides additional fuel during acceleration and power enrichment system provides a richer air/fuel mixture for high power output.

In addition to these 4 basic systems, both carburetors are equipped with a fuel inlet system which provides a constant fuel supply for the metering systems and a choke system which temporarily enriches the air/fuel mixture to aid in starting and running a cold engine.

Major differences are in external attachments used by each manufacturer. Ford models without A/C are equipped with a throttle solenoid positioner (TSP) to prevent dieseling when ignition is turned off. Ford models with A/C are equipped with a solo-kicker (2-stage throttle kicker) which consists of an electric solenoid and vacuum kicker. The solenoid operates in same manner as TSP to prevent dieseling and the kicker increases idle speed when A/C is activated. The A/C idle speed is not adjustable by the vacuum kicker. Chrysler models are equipped with a solenoid idle stop (SIS). The SIS increases idle speed when either A/C or rear window defogger is in operation.

All carburetors are equipped with an electronic bowl vent solenoid. This allows fuel vapors to vent to the carbon canister when the ignition is off. With the ignition on, the valve is closed and fuel bowl vents internally into air horn. All carburetors are also equipped with tamper-proof mixture adjustment screws.

### TESTING

#### ELECTRONIC BOWL VENT SOLENOID CHECK

**NOTE** — No adjustment or check of bowl vent is provided for Chrysler Corp. models.

- 1) Remove air cleaner assembly and turn ignition switch on. Attach hand vacuum pump to carburetor canister vent hose connector and apply 5-10 in. Hg.
- 2) If no vacuum is held, remove air horn and service or repair bowl vent assembly. If vacuum is held, apply same amount of vacuum to internal vent tube. If vacuum is not held, remove air horn and service or repair bowl vent assembly.
- 3) If vacuum is held at both points, the bowl vent is operating properly. Install air cleaner assembly and turn ignition off.

### ADJUSTMENT

#### HOT (SLOW) IDLE RPM

See appropriate article in TUNE-UP SERVICE PROCEDURES.

#### IDLE MIXTURE

See appropriate article in TUNE-UP SERVICE PROCEDURES.

#### COLD (FAST) IDLE RPM

See appropriate article in TUNE-UP SERVICE PROCEDURES.

#### FLOAT LEVEL

- 1) With air horn removed, invert main body. Catch accelerator pump check ball and weight if not previously removed. Hold float hinge pin retainer in place with finger. See Fig. 1.
- 2) On Chrysler Corp. models, leave air horn gasket in place. On all models place a straight edge across air horn gasket surface across toes of both floats.
- 3) To adjust on all models, bent float tang. Make sure floats are correctly aligned with walls of float bowl and that they move freely through full travel.

**NOTE** — Make sure accelerator pump check ball and weight are reinstalled if removed.

### HOLLEY MODEL 1945 & 1946-1V SINGLE BARREL (Cont.)

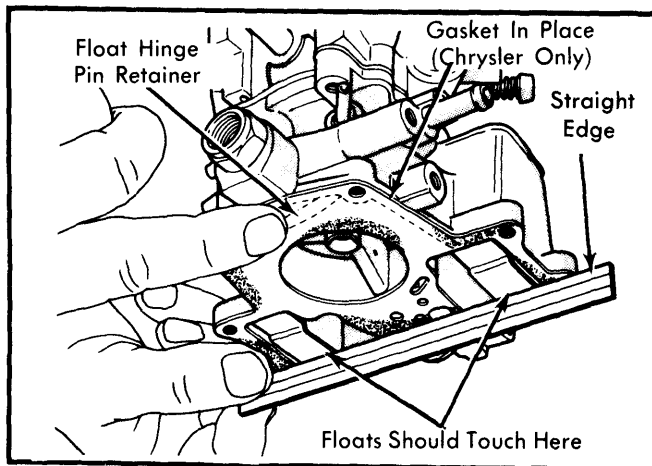
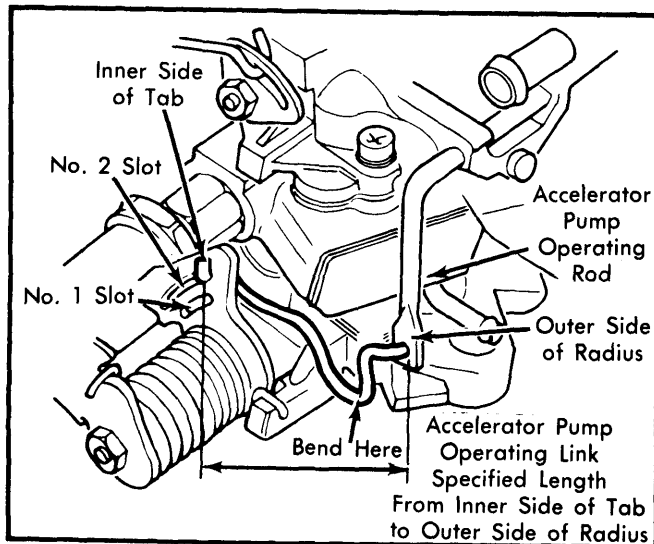

**Fig. 1 Adjusting Float Level**

#### ACCELERATOR PUMP

1) Make sure accelerator pump rod is in correct hole on Chrysler Corp. models or in the correct slot on Ford Motor Co. models. See Fig. 2.

**NOTE** — Inner hole or slot is designated number 1 and outer hole or slot is designated number 2.



**Fig. 2 Adjusting Accelerator Pump**

2) Place throttle lever in curb idle position. Measure accelerator pump distance between inner side of tab to outer side of radius. See Fig. 2. To adjust, bend existing loop in accelerator pump operating link.

#### FAST IDLE CAM POSITION

1) Position fast idle speed screw on second step of fast idle cam against shoulder of highest step. Hold choke valve toward closed position with light finger pressure. See Fig. 3.

2) Measure fast idle cam specified clearance between upper edge of choke valve and air horn wall. Measurement can be checked using a specified drill or pin gauge.

3) To adjust, bend fast idle cam rod. On Ford Motor Co. models, rod is located between automatic choke housing. To adjust, bend rod at "U" shaped bend.

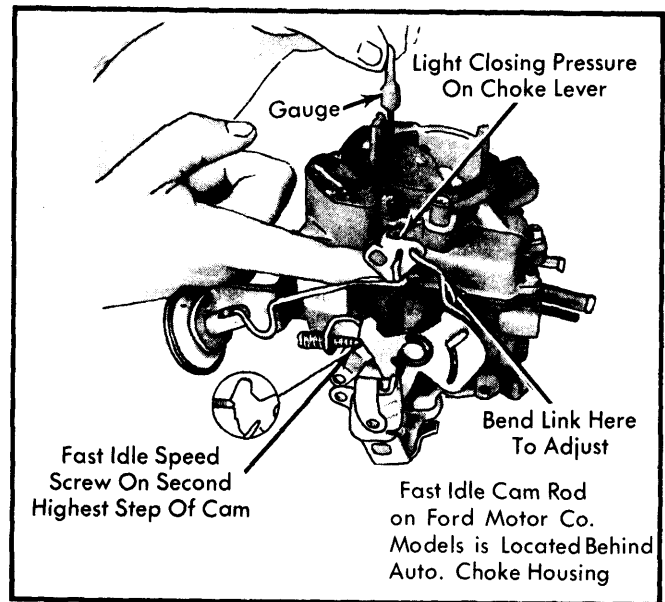
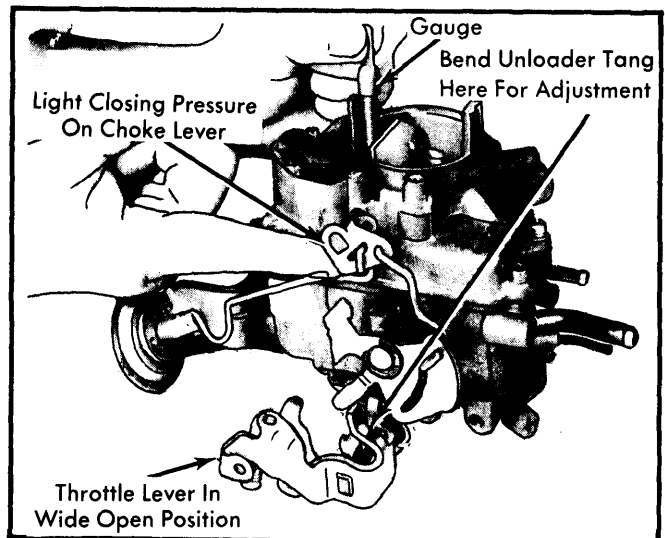

**Fig. 3 Adjusting Fast Idle Cam Position (Chrysler Corp. Model Carburetor Shown)**

#### CHOKE UNLOADER

1) Hold throttle valves in wide open position. Hold choke valve toward closed choke position by applying light closing pressure to choke lever. See Fig. 4.

2) Measure choke unloader specified clearance between upper edge of choke valve and air horn wall. Measurement can be checked using a specified drill or pin gauge. To adjust, bend choke unloader tang.



**Fig. 4 Adjusting Choke Unloader**

#### CHOKE VACUUM KICK (CHOKE PULLDOWN)

1) On Chrysler Corp. models, open throttle then close choke. Now close throttle to trap fast idle cam at closed choke position. See Fig. 5.

2) On Ford Motor Co. models, remove choke cover retaining rivets. Rotate choke cover in rich direction to close choke valve, then turn cover an additional 90°. Tighten 1 retaining screw.

## HOLLEY MODEL 1945 & 1946-1V SINGLE BARREL (Cont.)

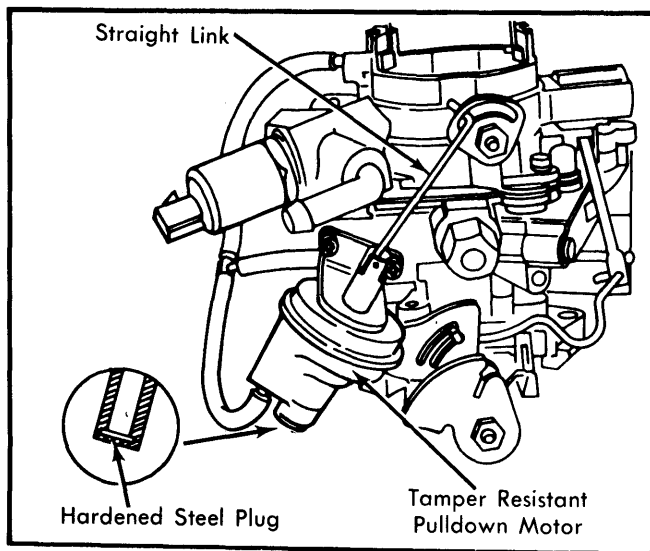

**Fig. 5 Adjusting Choke Vacuum Kick (Ford Motor Co. Model Shown)**

**3)** On Chrysler Corp. models, connect an outside vacuum source of at least 15 in. Hg to choke vacuum diaphragm. Apply enough closing pressure on choke valve to compress spring in choke diaphragm without distorting linkage.

**4)** On Ford Motor Co. models, remove tamper-proof steel plug. Apply outside vacuum source to activate pull down motor and measure choke vacuum kick specified clearance between upper edge of choke valve and air horn wall. To adjust, turn adjusting screw in or out as required.

**5)** On Chrysler Corp. models, insert a 5/64" Allen wrench into diaphragm and turn to adjust choke vacuum kick. Check for free movement between open and adjusted positions. Correct binding by rebending link and readjusting.

### OVERHAUL

**NOTE** — Ford Motor Co. models are equipped with tamper-proof choke cap assembly. To remove choke cap assembly, ensure rivet mandrels of bi-metal assembly are well below rivet head and drive mandrel down or out with a 1/16" diameter punch. Using a 1/8" (No. 30) drill, drill out rivet head and drive out rivet with a 1/8" punch. Remove standard screws and choke cap.

### DISASSEMBLY

**Air Horn** — **1)** Place carburetor on suitable repair stand. On Ford Motor Co. models, remove 2 pull-down diaphragm bracket screws, disconnect vacuum hose from main body and remove pull-down diaphragm and linkage assembly. On all models, remove bowl vent assembly.

**NOTE** — Do not clean pull-down diaphragm or bowl vent assemblies in carburetor solvent.

**2)** On Chrysler Corp. models, remove solenoid idle stop. On all models, remove fast idle cam retaining clip, fast idle cam and link.

**3)** On Ford Motor Co. models, remove choke control lever retaining screw. Remove throttle return spring bracket attaching nut and lock washer. Disengage return spring and carefully remove spring and bracket, noting specific accelerator pump link slot for reassembly reference.

**4)** On Chrysler Corp. models, remove choke vacuum diaphragm, link and bracket assembly. Disengage link from slot in choke lever and place diaphragm aside. Remove throttle shaft nut and washer. Note position of throttle lever for reassembly reference and remove throttle lever and link.

**NOTE** — Do not clean diaphragm assembly in carburetor solvent.

**5)** On all models, remove bowl cover screws and remove air horn from main body by tapping loose with plastic hammer. Lift cover straight up until vacuum piston stem, accelerator pump and main well tube are clear of main body.

**6)** Place air horn upside down on bench and remove gasket. Do not scrape with metal scraper. Use suitable cleaner or nylon scraper to prevent damage to casting gasket surface.

**7)** Remove accelerating pump operating rod screw and retainer, and accelerator pump assembly retaining screw and pump assembly. Rotate pump operating rod and remove pump drive spring and accelerator pump assembly.

**NOTE** — Manufacturer does not recommend removal of choke valve and shaft unless replacement is required.

**8)** Remove pump operating rod and grommet. Remove 3 screws retaining power enrichment valve and remove power valve diaphragm assembly. On Ford Motor Co. models, remove bowl vent valve seat by holding seat against internal vent tube with thin screwdriver and pulling actuating pintle loose from seat.

**NOTE** — Main well tube cannot be removed and must be carefully blown out from both sides of cover with compressed air.

**Main Body** — **1)** Remove fuel inlet fitting valve assembly. Remove and discard old gaskets. Remove float shaft retainer, shaft and float assembly. Turn main body upside down and catch pump discharge weight and ball as they fall out.

**2)** Remove main metering jet with jet wrench or 3/8" wide flat screwdriver. Remove power enrichment valve needle with 3/8" wide screwdriver.

**NOTE** — Screwdriver should be modified by cutting a 1/16" wide and 3/8" deep slot in center of blade. This provides clearance for valve stem.

**3)** Remove 3 main body-to-throttle body screws and separate assemblies. Remove and discard gasket. On Ford Motor Co. models, remove low idle speed (TSP Off) adjusting screw and spring, and remove solenoid.

**Throttle Body** — **1)** Remove curb idle adjusting screw. On Ford Motor Co. models, remove fast idle speed adjusting screw and spring.

**2)** On Chrysler Corp. models, clamp throttle body in padded vise with mixture plug facing up. Drill a 5/64" hole in casting at idle mixture screw at a 45° angle toward plug. Redrill hole to 1/8". Insert blunt punch and drive out plug. Remove idle mixture screw and spring. See Fig. 7.

**NOTE** — Manufacturers do not recommend removal of throttle plate or shaft. If damage or wear is evident, replace throttle body assembly.

**3)** On Ford Motor Co. models, drill a 3/32" hole in plug. Install screw extractor and remove plug. Turn mixture screw clockwise until it lightly seats, recording number of turns for reassembly reference. Remove mixture screw and spring.

# 1982 Holley Carburetors

## HOLLEY MODEL 1945 & 1946-1V SINGLE BARREL (Cont.)

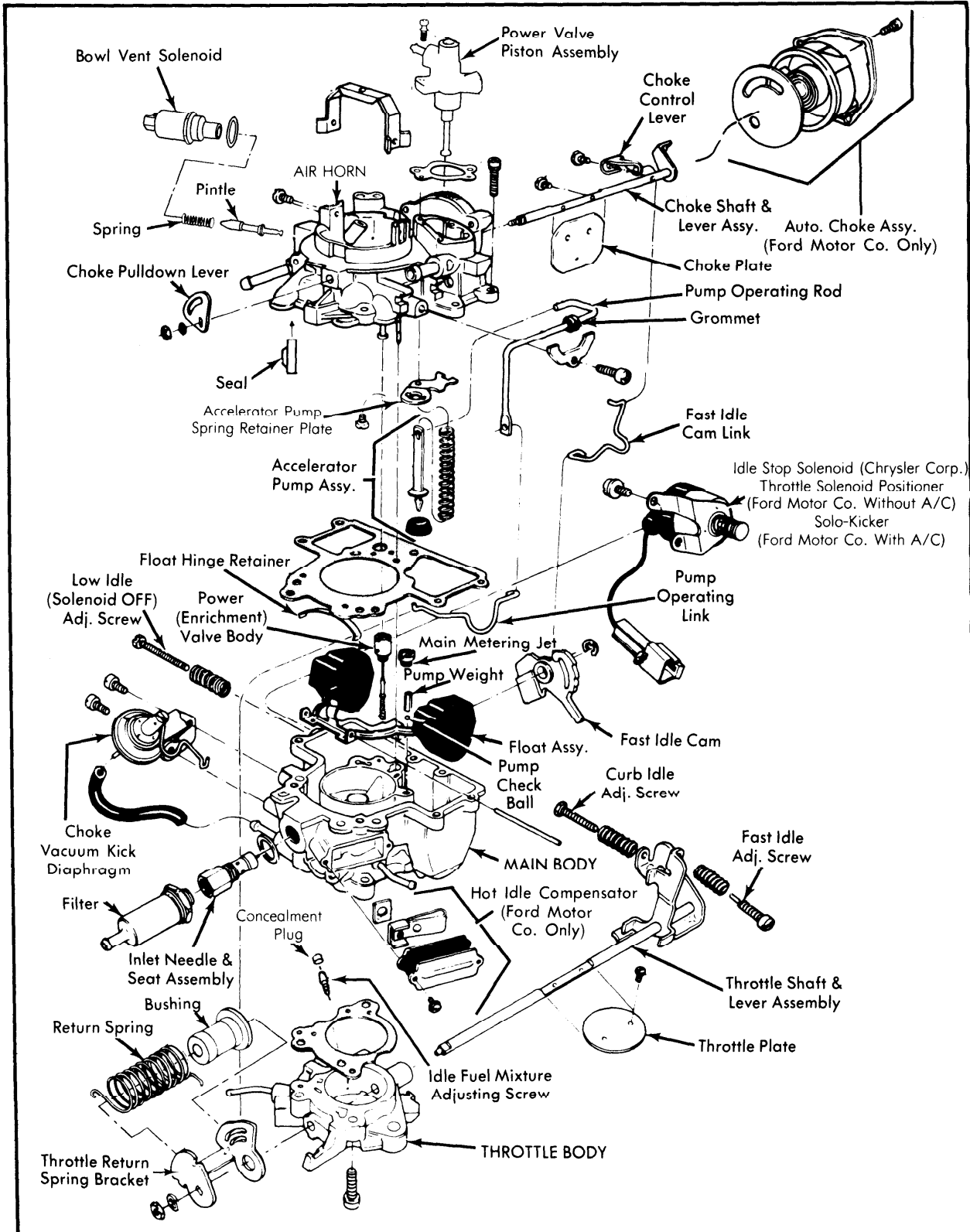
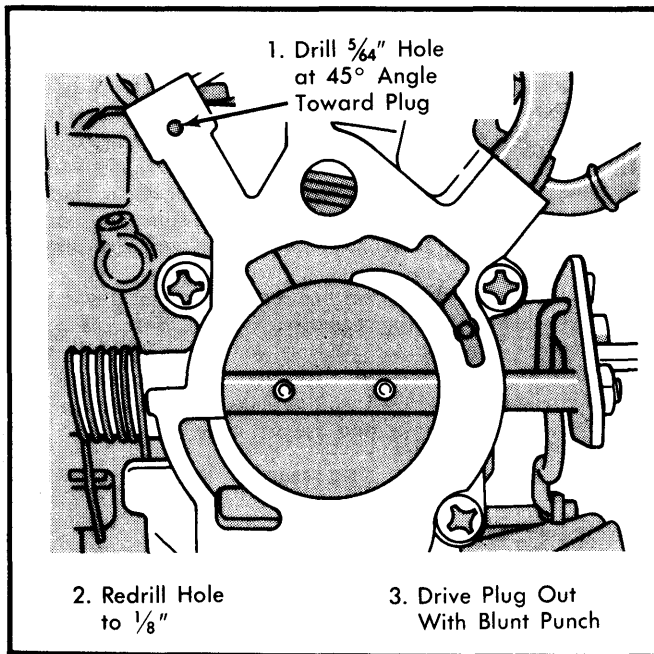

Fig. 6 Exploded View of Holley Model 1946-1V Carburetor

## HOLLEY MODEL 1945 & 1946-1V SINGLE BARREL (Cont.)



**Fig. 7** Removing Idle Mixture Screw Concealment Plug (Chrysler Corp. Model Shown)

### CLEANING & INSPECTION

- Do not place choke cover, pulldown diaphragm assembly, bowl vent assembly or pump plunger in cleaning solvent.
- Inspect all gasket mating surfaces for nicks, burrs or any damage that would prevent gasket sealing.
- Inspect idle mixture screw tip. If grooved or worn, replace with new needle.
- Ensure all new gaskets match gaskets removed in placement of holes and slots. Use new gaskets only.
- Ensure all parts are clean and free of solvent before assembly. Wash parts in hot water and blow dry with compressed air.

### REASSEMBLY

Reassemble carburetor in reverse order of disassembly. Use new gaskets and seals. Make sure gaskets fit correctly and all holes are punched through and correctly located. Install mixture screw concealment plug after final adjustments are made on vehicle.

**NOTE** — Choke cap must be installed with rivets on Ford Motor Co. models to maintain tamper-proof requirement.

### CARBURETOR ADJUSTMENT SPECIFICATIONS

Application	Float Level Setting	Accelerator Pump		Fast Idle Cam Setting	Choke Unloader Setting	Choke Vacuum Kick Setting	Auto. Choke Setting	Bowl Vent Setting
		Hole Setting	Rod Setting					
<b>Chrysler Corp. (1945)</b> R-9627A R-9628A	Flush <sup>①</sup>	#2	1.615"	.090"	.250"	.150"	.....	.....
	Flush <sup>①</sup>	#2	1.615"	.090"	.250"	.150"	.....	.....
<b>Ford Motor Co. (1946-1V)</b> E2BE-9510-BA E2BE-9510-CA E2BE-9510-SA E2BE-9510-TA	.69" <sup>②</sup>	#2	2.395"	.078"	.150"	.110"	2NR	.....
	.69" <sup>②</sup>	#2	2.395"	.078"	.150"	.110"	2NR	.....
	.69" <sup>②</sup>	#2	2.395"	.078"	.150"	.110"	2NR	.....
	.69" <sup>②</sup>	#2	2.395"	.078"	.150"	.110"	2NR	.....

- ① — See adjustment procedure.  
② — Wet setting.