

DELCO-REMY HIGH ENERGY IGNITION

Chevrolet
GMC
Jeep
4 Cylinder

DESCRIPTION

NOTE — Some Chevrolet and GMC light truck models with 5.0L VIN H engines are equipped with Electronic Spark Control to combat detonation.

The Delco-Remy High Energy Ignition system consists of a battery, ignition switch, spark plugs, primary and secondary wiring and a special distributor assembly.

The distributor housing and cap contain vacuum and centrifugal advance mechanisms, an electronic control module, pick-up coil, pole piece (with internal teeth), timer core (with external teeth), rotor, distributor shaft and a capacitor for radio noise suppression.

Full battery voltage is present at the battery terminal of the distributor in either the "START" or "RUN" position, as no ballast resistance wire is used.

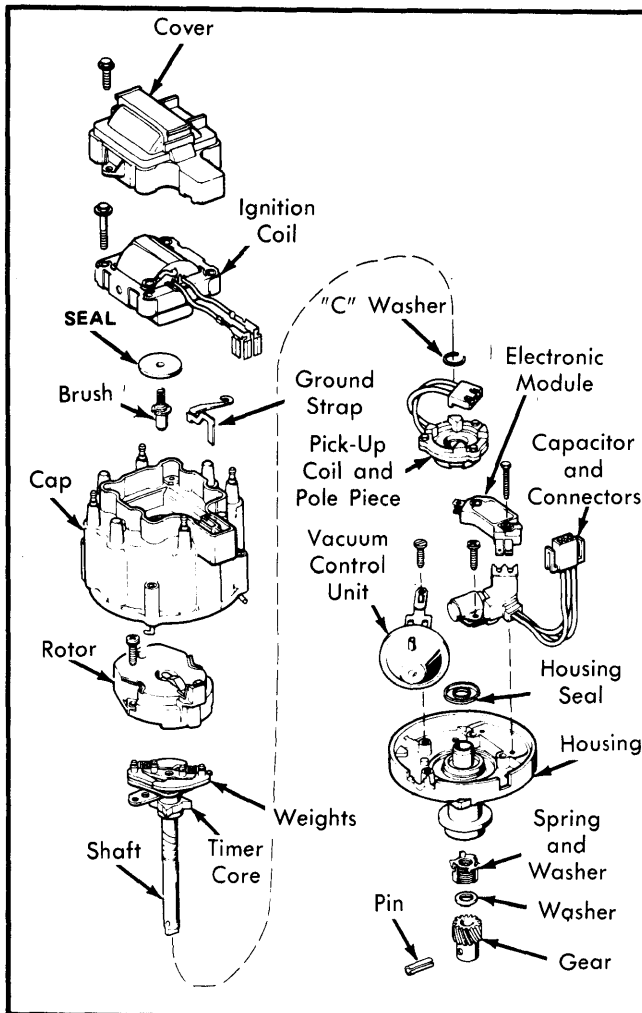

Fig. 1 Exploded View of Integral Coil Type HEI Distributor (Jeep 4-Cylinder Shown)

OPERATION

The pick-up coil assembly consists of a permanent magnet, a pole piece and a pick-up coil. The pick-up coil assembly is

stationary, unless it is shifted by the vacuum control unit. The timer core position can also be shifted by the centrifugal weights.

The timer core, mounted on the distributor shaft, rotates with the shaft inside the pole piece portion of the pick-up coil assembly. When the external teeth of the timer core line up with the internal teeth of the pole piece, a voltage is induced in the pick-up coil. This signals the electronic module inside the distributor, which opens the ignition coil primary circuit. See Fig. 2.

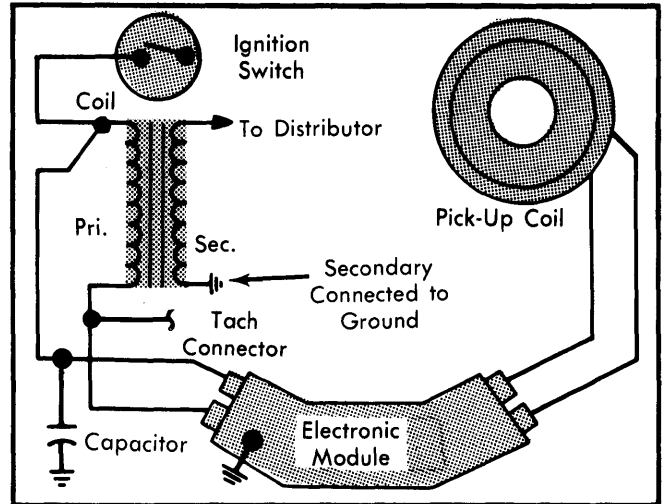

Fig. 2 Delco-Remy High Energy Ignition System Basic Wiring Diagram

The magnetic field in the ignition coil primary circuit collapses, inducing high voltage in the coil's secondary circuit. This travels through the distributor cap contact, rotor and secondary wires to fire the spark plugs.

The electronic module automatically controls dwell period, stretching it with increasing engine speed. Dwell is not adjustable and periodic checks of dwell are unnecessary. The HEI system features a longer spark duration, which is desirable for firing lean and EGR diluted mixtures.

TESTING

NOTE — During testing procedures, the following precautions must be observed. Do not ground tachometer terminal of distributor connector. Disconnect ignition switch connector at distributor before making compression checks. To remove spark plug wires, twist boot 1/2 turn and pull on boot (not on wire). When using a timing light connect at plug end of number 1 spark plug wire (do not pierce plug boot).

Check that wiring connector is properly attached to connector at side of distributor cap and that spark plug leads are properly connected at both ends before continuing with test procedures.

ENGINE WILL NOT START

NOTE — If engine is difficult to start or misses, check position of battery terminal connector at distributor cap. Terminal must be inserted on side of connector opposite hold-down clip.

Connect voltmeter between "BAT" terminal lead on distributor connector and ground. Turn ignition switch on. If voltage is zero, check system for open circuit. If reading is battery

DELCO-REMY HIGH ENERGY IGNITION (Cont.)

voltage, connect a modified spark plug (plug that has ground electrode cut off) to center brush contact in distributor cap. Crank engine, if spark occurs trouble is not in ignition system. Check fuel system, spark plugs and wires for trouble. If sparking does not occur, follow procedures under **SYSTEM TESTING** or **COMPONENT TESTING**. See Fig. 3.

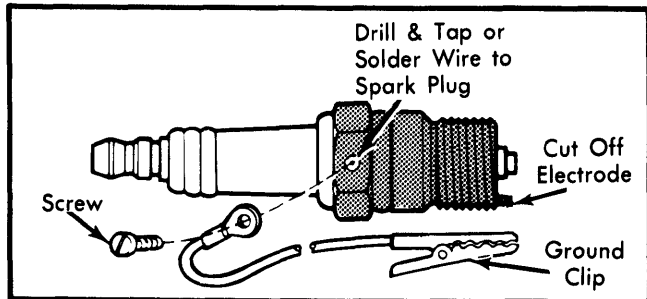

Fig. 3 Modifying Spark Plug for Testing

ENGINE STARTS BUT RUNS ROUGH

Check for proper fuel delivery to carburetor, vacuum hoses for leakage, ignition timing, centrifugal advance for proper operation, spark plugs for defects, and visually inspect and listen for sparks jumping to ground or to other wires. If no defects are found or condition continues after correction, follow procedures under **SYSTEM TESTING** or **COMPONENT TESTING**.

SYSTEM TESTING

- 1) Connect voltmeter positive lead to distributor battery terminal and negative lead to ground. Crank engine. If voltage is under 7 volts, repair or replace wiring or components back to battery, including ignition switch and all connections.
- 2) If voltmeter reading in step 1) was 7 volts or more, connect positive lead of voltmeter to "TACH" terminal of distributor, while leaving negative lead attached to ground. If reading is 10 volts or more, proceed to step 4).
- 3) If reading in step 2) was under 1 volt, replace ignition coil. If reading was 1-10 volts, replace electronic HEI module in distributor and check for spark as instructed in step 7). If spark results, system is OK. If no spark results, replace ignition coil in addition to the module.
- 4) If reading in step 2) was 10 volts or more, remove distributor cap, but leave wiring harness attached to cap connector. Connect spark tester (ST-125) or modified spark plug so terminal touches center contact of cap. Ground tester ground wire, and crank engine. See Fig. 4.
- 5) If spark occurs, inspect cap for water, cracks, or other defects. If cap is OK, replace rotor. If no spark occurred in step 4), remove pick-up coil leads (Green and White wires) from module. Again, check voltage at "TACH" terminal of distributor cap. Attach voltmeter positive lead to terminal and negative lead to ground. See Fig. 5. Turn ignition switch on. Observe voltmeter reading as you attach test light to battery positive terminal and momentarily (no more than 5 seconds) touch other test light lead to module terminal "G" (small terminal).

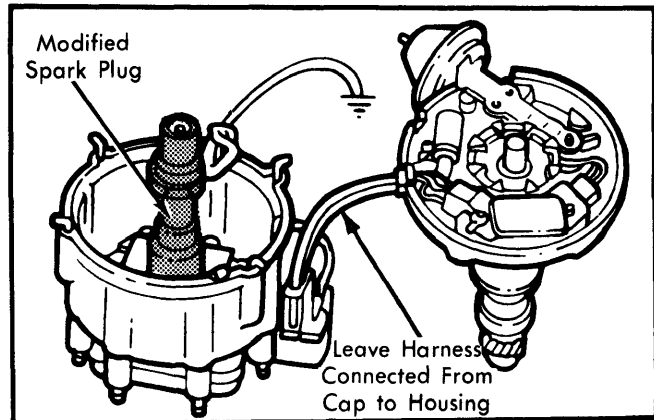

Fig. 4 Checking for Spark at Ignition Coil Output Terminal

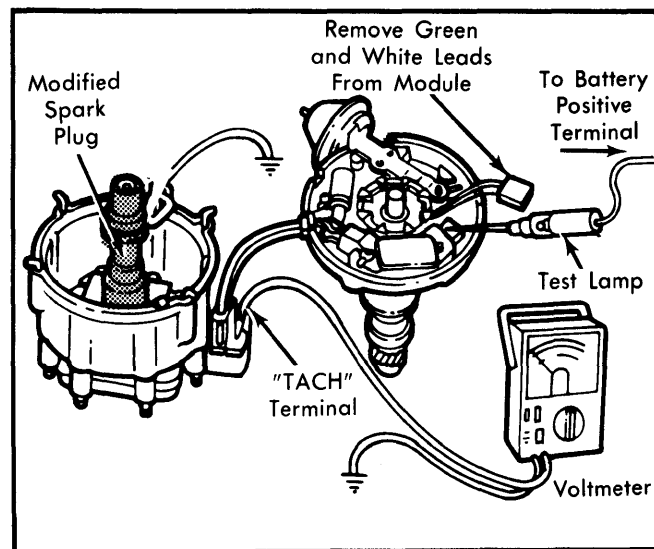

Fig. 5 Checking Distributor Components with Voltmeter and Test Light

- 6) If voltage did not drop, check module ground. Also check for open in wires from distributor to cap. If OK, replace HEI module.
- 7) If voltage dropped in step 5) when test light was connected, or if 1-10 volts was recorded in step 2), check for spark at coil center contact (using spark tester as before) as test light is removed from module's "G" terminal.
- 8) If spark results, replace pick-up coil assembly. If no spark, appears use module tester to test HEI module. If OK, check ignition coil ground. If ground is OK, replace ignition coil. If module is defective, replace it.
- 9) If no module tester is available, check ignition coil ground circuit. If OK, replace ignition coil and repeat step 7). If spark results, system is OK. If no spark results, original coil is OK. Replace module.

INTERMITTENT SYSTEM PROBLEMS

- 1) Using a spark tester or modified spark plug, check for spark at 2 spark plug wires. If no spark results, see **SYSTEM TES-**

DELCO-REMY HIGH ENERGY IGNITION (Cont.)

TING. If spark is noted on one or both wires, check for dwell increase from low to high RPM.

2) Check pick-up coil with ohmmeter leads attached to Green and White wires, removed from HEI module. If reading does not fall between 500-1500 ohms, replace pick-up coil. If pick-up coil reading was satisfactory, and dwell did not increase, replace electronic module.

3) If pick-up coil was satisfactory, but dwell increased, check fuel, spark plug wires, distributor cap, rotor or spark plugs.

COMPONENT TESTING

Distributor Cap & Coil Testing – 1) Remove distributor cap and coil assembly by removing wiring harness connector, battery lead, and cap-to-housing latches. Inspect rotor, cap and coil assembly for arc-over. Replace parts as necessary.

2) To test coil primary resistance, connect one ohmmeter lead to battery terminal on distributor cap. See Fig. 6. Connect other lead to tach terminal of distributor cap. Ohmmeter reading should be 0.4-1.0 ohm. Connect ohmmeter leads to tach terminal and ground. Reading should be infinity. If either reading is not to specifications, replace ignition coil.

3) To test coil secondary resistance, connect one ohmmeter lead to coil secondary contact (cap button). See Fig. 6. Connect other lead to tach terminal. Ohmmeter reading should be infinity.

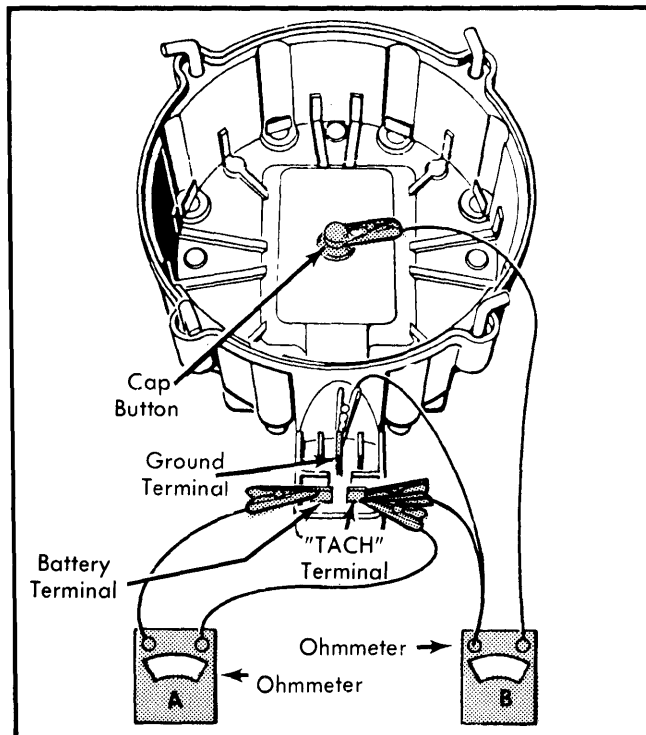

Fig. 6 Distributor Cap and Coil Testing Connections for Delco-Remy HEI Distributor

4) Move ohmmeter lead from tach terminal and attach it to ground terminal. Secondary-to-ground ohmmeter reading should be 6,000-30,000 ohms. If these tests are not to specifications, replace ignition coil.

NOTE – Replace ignition coil only if readings in both steps 3) and 4) are infinity.

Pick-Up Coil – 1) Connect test stand vacuum source to vacuum advance unit. If vacuum advance unit is inoperative, replace unit. To check pick-up coil for shorts, connect ohmmeter leads as shown by meter "A" in Fig. 7. Set on middle scale of meter. Operate vacuum advance through range. Reading should be infinite at all times. If not, replace pick-up coil.

2) To check pick-up coil resistance, connect ohmmeter leads as shown by meter "B" in Fig. 7. Again use the middle scale. Operate vacuum advance through its range. Ohmmeter reading should be 500-1500 ohms in all advance positions. If readings are not as specified, replace pick-up coil.

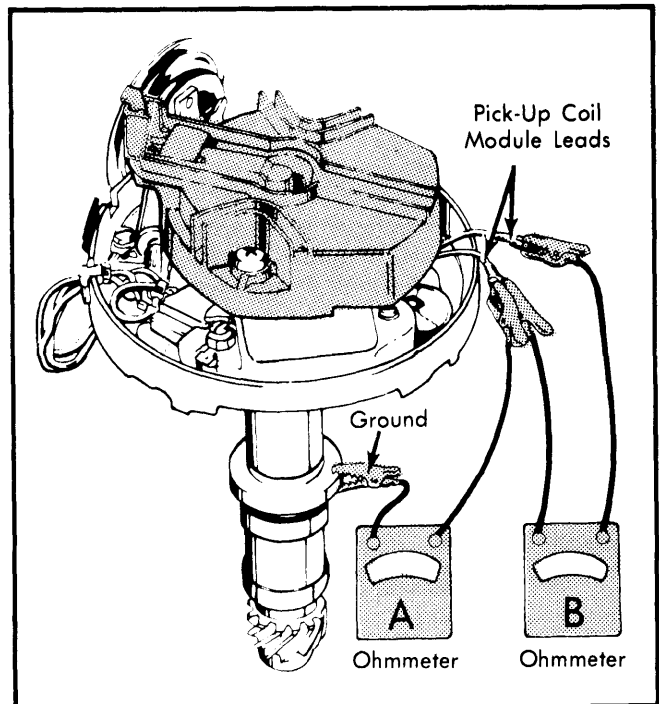

Fig. 7 Distributor Pick-Up Coil Testing Connections

Capacitor – Set ohmmeter in x1000 scale. Disconnect capacitor. Touch ohmmeter leads to capacitor terminal and to ground. The needle should move slightly, but very quickly, and return to infinity. Any continuous reading other than infinity indicates defective capacitor.

Electronic Module – If engine operation remains rough after preceding test procedures are completed, replace the electronic module.

NOTE – When installing a new HEI module, use silicone lubricant on back of module and on housing under module.

ELECTRONIC SPARK CONTROL TESTING

NOTE – Electronic Spark Control is used on some Chevrolet and GMC models using the 5.0L VIN H engine.

DELCO-REMY HIGH ENERGY IGNITION (Cont.)

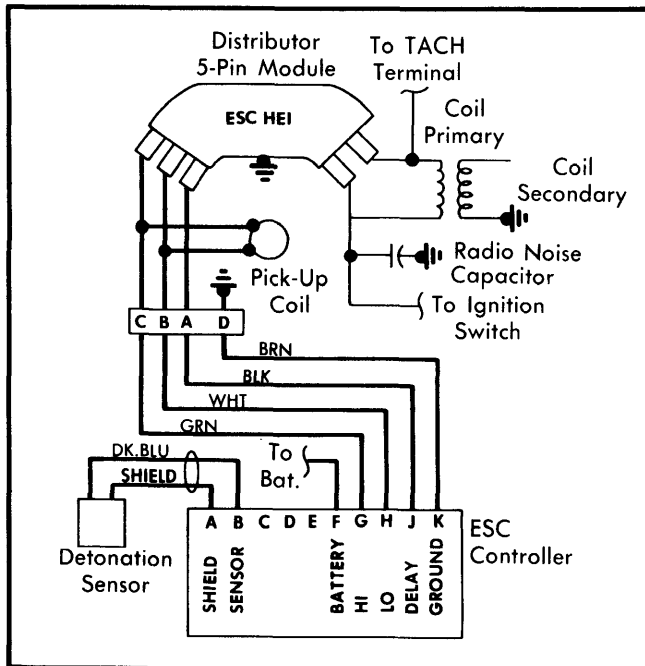

Fig. 8 Wiring Diagram for HEI System with Electronic Spark Control

Detonation Problems – 1) With engine running at fast idle speed and transmission in Neutral or Park, tap exhaust manifold lightly and repeatedly. Check for spark timing retard with a timing light. If retard is noted, check other engine detonation causes.

2) If no retard occurs, disconnect 10-pin connector from ESC controller in passenger compartment. Connect ohmmeter leads between pins "B" and "K" of connector. Resistance should be 175-375 ohms. If so, proceed to step 4).

3) If resistance reading was either high or low, disconnect detonation sensor wire. Measure resistance by connecting ohmmeter leads to sensor terminal and ground. Reading should be 175-375 ohms. If high or low, replace sensor. If OK, check wires from pins "A", "B", and "K" of 10-pin connector for opens or shorts. If OK, repair sensor connector. If not OK, replace or repair wiring harness.

4) If resistance reading in step 2) was OK, try to start engine with 10-pin connector disconnected. If it starts, replace distributor's HEI module.

5) If engine will not start, reconnect 10-pin connector to controller. Disconnect sensor wire from sensor, and insert a jumper wire into sensor wire connector. With engine running at fast idle speed, lay wire on top of distributor over ignition coil. If spark timing retard occurs, replace sensor.

6) If no spark retard occurs, connect voltmeter positive lead to pin "H" of 10-pin connector and negative lead to pin "K". With ignition switch on, voltage should read more than 0.2 volt. If voltage is more than 0.2 volt, replace ESC controller. If less than 0.2 volt, repair open wire from pin "H" in ESC harness.

Poor Engine Performance Problems – 1) Disconnect 4-pin connector at distributor and install a jumper wire between pins "A" and "C" of distributor connector. If problem remains, check other causes of poor engine performance.

2) If problem disappeared, remove jumper wire and reconnect 4-pin connector. Without disconnecting 10-pin ESC connector, attach jumper wire from pin "A" to pin "B". If problem remains, proceed to step 5).

3) If problem disappeared in step 2), remove jumper wire and disconnect 10-pin connector at controller. Connect ohmmeter leads to pins "B" and "K". Resistance should read 175-375 ohms. If OK, check for engine noises other than detonation that might cause input to sensor.

4) If resistance reading was either high or low in step 3), disconnect wire from sensor. Measure resistance from terminal to ground, checking again for 175-375 ohms. If high or low, replace sensor. If OK, check sensor wire and shield for open circuit. If OK, repair sensor connector. If not OK, repair harness.

5) If in step 2), the problem still existed, remove jumper wire from pins "A" and "B". With engine running, connect positive voltmeter lead to pin "F" and negative lead to pin "K" of 10-pin connector. If reading is under 11.6 volts, repair alternator charging circuit.

6) If over 11.6 volts, check wires in ESC harness from pins "H" and "K" for open circuits or poor connections. If OK, replace ESC controller; if not, replace or repair harness.

Engine Starting Problems – 1) Check all ESC harness connections, including 10-pin connector, 4-pin connector at distributor, 2-blade male connector to distributor, and 2-blade female connector to ignition switch lead (Pink wire). Repair as necessary.

2) If all connections are OK, disconnect 4-pin connector at distributor. Install jumper wire between pins "A" and "C" of distributor connector. If engine will not start, check other causes of engine failing to start.

3) If engine starts with jumper wire attached, remove jumper wire and reconnect 4-pin connector to distributor. With ignition switch on, connect voltmeter positive lead to pin "F" and negative lead to Pin "K" on 10-pin connector. If under 7.0 volts, repair circuit between ignition switch and pin "F".

4) If over 7.0 volts are read, check wires in ESC harness from pins "G", "H", "J" and "K" of 10-pin connector for opens or shorts. If harness is OK, replace ESC controller.

OVERHAUL

DISASSEMBLY

1) Disconnect wiring harness from cap. Disconnect coil wire. Remove distributor cap and disconnect vacuum hose from vacuum advance unit. Mark rotor position to distributor housing and distributor housing to engine for reassembly reference. Remove hold-down bolt and remove distributor housing from engine.

2) Remove rotor, two advance springs, weight retainer and advance weights. Mark distributor shaft and gear so they may be assembled in same position. Drive out roll pin from drive gear while supporting gear so no damage will occur to distributor shaft. Remove gear, shim and tanged washer from distributor shaft and clean any burrs from shaft. Remove distributor shaft from housing.

DELCO-REMY HIGH ENERGY IGNITION (Cont.)

NOTE — Do not attempt to service shaft bushings in housing.

3) Remove 2 attaching screws holding module-to-housing and position module to disconnect pick-up coil and wiring harness connectors. Remove "C" washer from housing and lift pick-up coil assembly from advance unit and distributor shaft.

4) Remove 2 attaching screws and remove vacuum advance mechanism. Disconnect capacitor lead, remove attaching screw and capacitor. Remove wiring harness from position in distributor housing.

5) Remove 3 coil cover attaching screws and lift off cover. Remove 4 ignition coil attaching screws, disconnect coil leads and remove coil from cap. Remove ignition coil arc seal.

REASSEMBLY

Reverse disassembly procedures while noting following: Ensure there is special silicone lubricant between module and distributor base to provide heat transfer for module cooling. Lubricate felt washer with a few drops of engine oil. After installation of distributor shaft, rotate to check for even clearance between external timer core teeth and internal pole piece teeth. Notch on side of rotor must engage tab on cam weight base.

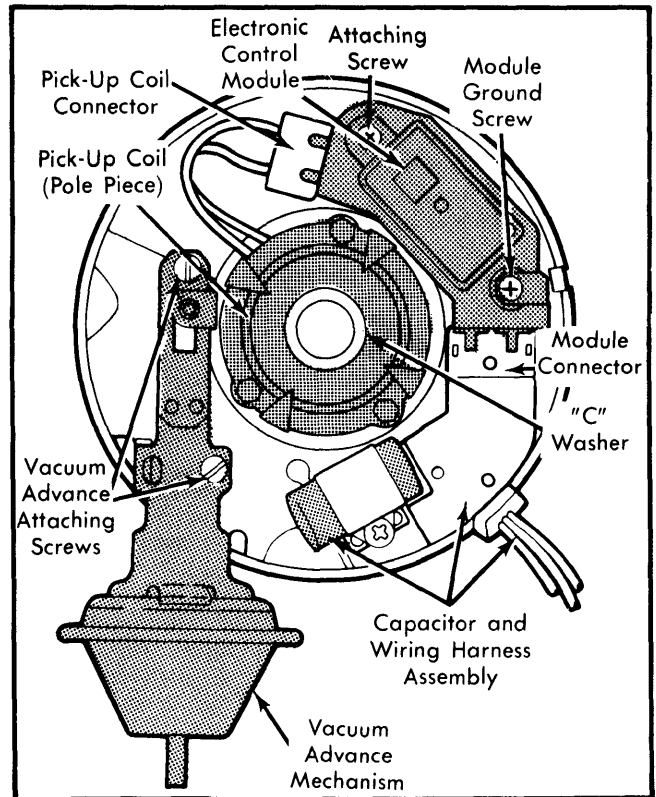

Fig. 9 Internal Components of HEI Distributor

TYPICAL DELCO-REMY HIGH ENERGY IGNITION OSCILLOSCOPE PATTERNS

PRIMARY PATTERNS (TYPICAL)

Scope Instructions for Primary Parade Only:

NOTE — Also refer to scope manufacturers' instructions.

- 1) Scope secondary pick-up cannot be connected because coil center terminal is inside distributor.
- 2) Connect pick-up to No. 1 spark plug wire as usual.
- 3) Connect primary pick-up to "Tach" terminal at distributor connector plug.

Reading Scope Primary Pattern

- A) Spark Zone — spark plug arcing.
- B) Coil and Condenser Zone
- B1) Firing Zone — no plug arc.
- C) Dwell Zone — displays current through coil primary with module turned on.

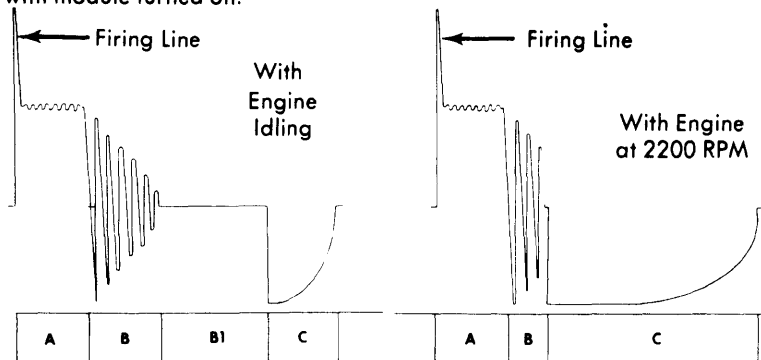

Primary Parade Pattern for One Cylinder Only

SECONDARY PATTERNS (TYPICAL)

NOTE — A special adapter placed on top of the coil-cap assembly may be used with some scopes to view the secondary pattern. The output voltage will read low with the adapter; this is normal. Refer to the scope manufacturers' instructions.

Secondary Voltage Patterns:

It is normal if dwell time varies from cylinder to cylinder. A 40 to 60 percent variation is shown below. It could be more, or it could be less. The voltage ripple shown may or may not appear; either is normal. Variation in dwell time or voltage ripple, as shown, does not necessarily indicate a bad module.

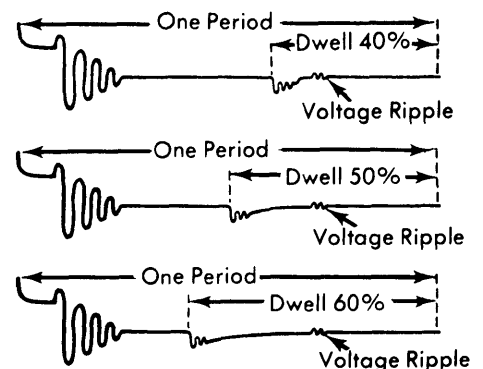

Typical Secondary Scope Patterns. See Scope Instructions for Actual Patterns