

Distributors & Ignition Systems

CHRYSLER CORP. ELECTRONIC IGNITION

Dodge & Plymouth
All V8 Models

DESCRIPTION

All Dodge and Plymouth vehicles with V8 engines use Chrysler Corp. Electronic Ignition. This system consists of an electronic control unit, an ignition coil, a 1.25 ohm ballast resistor and a distributor with both vacuum and centrifugal advance mechanisms. See Fig. 1 and 2.

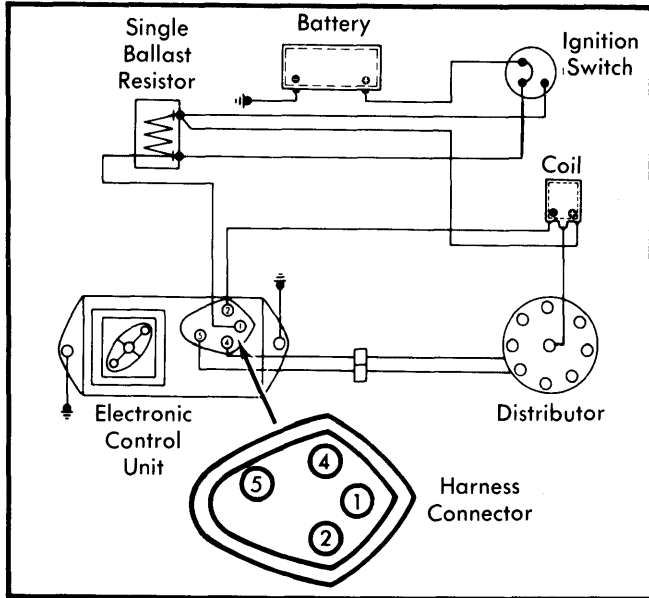

Fig. 1 Electronic Ignition Wiring Diagram for V8 Engines with Single Pick-Up Coil
(NOTE: No Terminal No. 3)

Distributors may vary between models, as some have a reluctor and single pick-up coil assembly, while other models have a reluctor and 2 pick-up coil assemblies. Models with dual pick-up coil assemblies also have a dual pick-up start-run relay, located between the electronic control unit and the distributor.

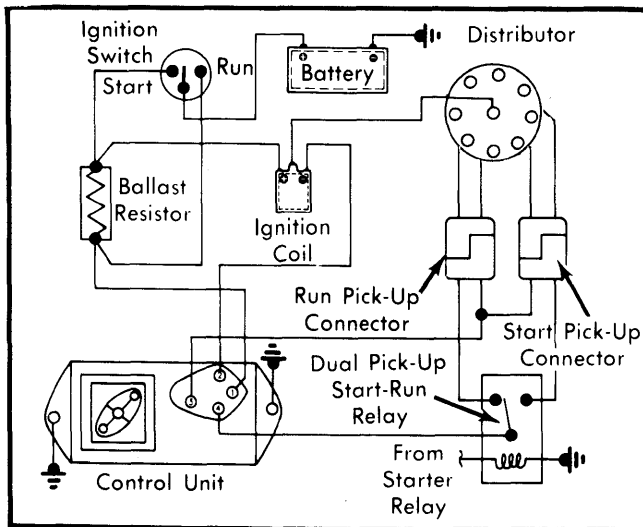

Fig. 2 Electronic Ignition Wiring Diagram for V8 Engines with Dual Pick-Up Coil
(NOTE: No Terminal No. 3)

The dual pick-up start-run relay permits use of a dual pick-up distributor without electronic spark advance. This results in improved timing and increased fuel economy.

The control unit is connected to the rest of the system through a 4-wire connector. The distributor is connected to the control unit by a 2-wire or by two 2-wire connectors (dual pick-up models).

NOTE — There is no terminal 3 on the control unit.

OPERATION

DISTRIBUTOR

Single Pick-Up Models — The distributor has a toothed wheel, called a reluctor, having one tooth for each of the engine's 8 cylinders. See Fig. 3. As the reluctor rotates with the distributor shaft, its teeth approach, become aligned with, and pass the center pole piece of the pick-up coil. This interruption of the magnetic field around the pick-up coil creates an electronic signal.

This signal is transmitted to the control unit, which shuts off current flow to the primary circuit of the ignition coil as each signal is received.

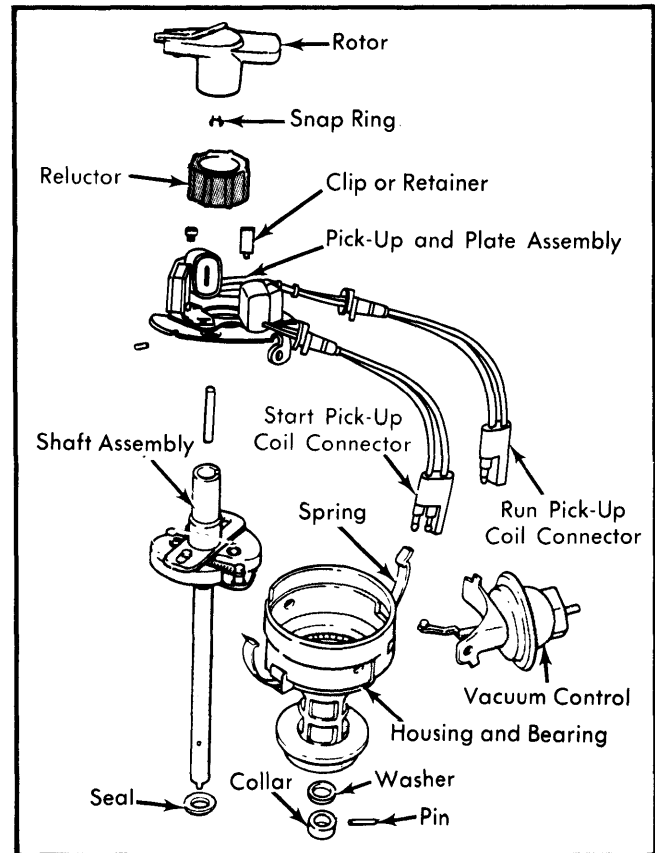

Fig. 3 Exploded View of Distributor Used on Dual Pick-Up System for V8 Engines

Dual Pick-Up Models — This system operates identically to single pick-up models with one exception. Signals are sent by different pick-up coils during cranking and normal running conditions.

CHRYSLER CORP. ELECTRONIC IGNITION (Cont.)

When cranking, the system operates through the start pick-up circuit of the dual pick-up start-run relay. Once the engine begins to run, the relay switches back to the run pick-up circuit. Only one pick-up coil operates at a time. Distributor pick-up coil connectors can be identified by their terminals. Run pick-up connectors have one male and one female terminal; start pick-up connectors have 2 male terminals.

ELECTRONIC CONTROL UNIT

The electronic control unit is located in a metal housing on the firewall. A switching transistor is exposed on top for more efficient cooling. The control unit is connected to the rest of the system by a wiring harness and a 4-wire connector. The control unit functions whenever the ignition switch is turned to the "START" or "RUN" positions.

The control unit furnishes current to the distributor pick-up coil directly on single pick-up models. On dual pick-up models, current flows through the dual pick-up start-run relay to either the start or run pick-up assembly, depending on whether ignition switch is in the "START" or "RUN" position.

The signal created, as the reluctor teeth pass the "live" pick-up coil, is transmitted by the control unit to the primary circuit of the ignition coil. As current to the primary is cut off, the magnetic field there collapses, causing a voltage surge in the secondary windings. This fires the spark plugs.

The length of time current is permitted to flow through the coil's primary circuit (dwell time) is determined by the control unit and is not adjustable.

BALLAST RESISTOR

A single 2-pin ballast resistor is used. During cranking, the resistor is by-passed, allowing full battery voltage to flow to the coil. In low speed operation, the ballast resistor limits voltage to the coil, protecting it from overheating. As engine speed increases, the ballast resistor allows the coil to charge faster to prevent voltage loss.

ADJUSTMENT

PICK-UP COIL AIR GAP

NOTE — On models with a single pick-up coil assembly, adjust air gap in same manner outlined for start pick-up coils. See Fig. 5.

1) To set **start** pick-up coil air gap, loosen hold-down screw and align one reluctor tooth with pick-up coil pole. Install .006" non-magnetic feeler gauge between reluctor tooth and pick-up coil pole. See Fig. 4. Move pick-up coil assembly until contact is made between pick-up coil pole, feeler gauge and reluctor tooth. Tighten hold-down screw and remove feeler gauge. Gauge should not require force during removal.

2) Check air gap of **start** pick-up coil using an .008" non-magnetic feeler gauge. It should not fit in gap. Do not force it to fit. Apply vacuum to vacuum unit and rotate distributor shaft. Pick-up coil pole should not strike reluctor teeth. If so, gap is incorrectly set. If pick-up coil pole strikes teeth only on one side, distributor shaft is probably bent, requiring replacement.

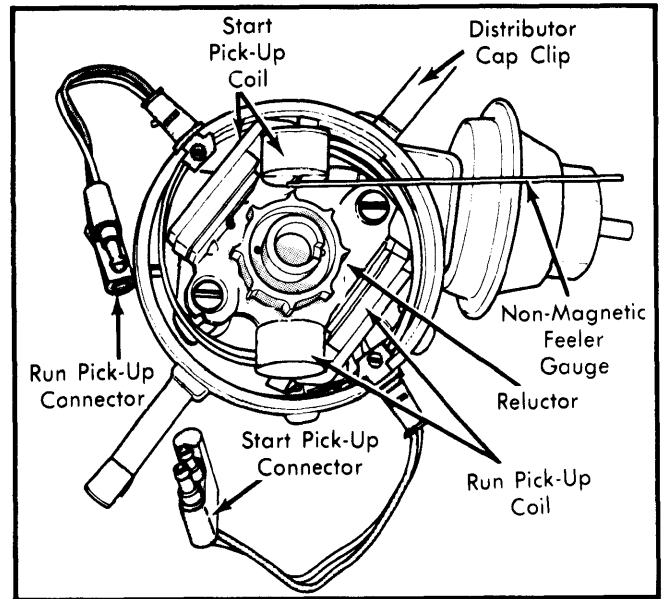

Fig. 4 Checking Air Gap of Dual Pick-Up Distributor Start Pick-Up Coil

NOTE — To adjust run pick-up coil air gap, use same procedure as for start pick-up coil, except set gap with a .012" feeler gauge and check it with a .014" gauge.

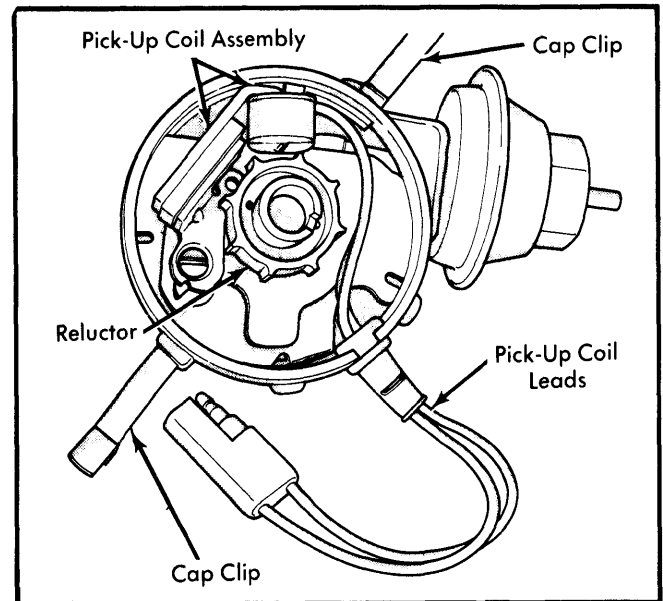

Fig. 5 Checking Air Gap of Single Pick-Up Distributor Pick-Up Coil

TESTING

NOTE — If a suitable tester (C-4166 with adapter C-4166-1 or C-4166-A, or tester C-4503 with adapter C-4503-3) is available, use tester and follow manufacturer's instructions. If tester is not available, proceed as follows:

Check that all secondary cables, primary wire at coil and ballast resistor are not loose and not cracked excessively. Use a voltmeter with a 20,000 ohm/volt rating and an ohmmeter which uses a 1 1/2 volt battery for its operation. Check calibration of both meters. Check and record battery voltage reading using voltmeter. Proceed with following tests.

CHRYSLER CORP. ELECTRONIC IGNITION (Cont.)

CAUTION — When removing or installing wiring connector, ignition switch must be in "OFF" position.

DUAL PICK-UP START-RUN RELAY (IF EQUIPPED)

1) Turn ignition switch "OFF". Remove 2-wire connector from dual pick-up start-run relay terminals 4 and 5. Using an ohmmeter, connect leads to terminals 4 and 5 of start-run relay. See Fig. 6.

2) Resistance reading should be 20-30 ohms. If not to specifications, replace dual pick-up start-run relay.

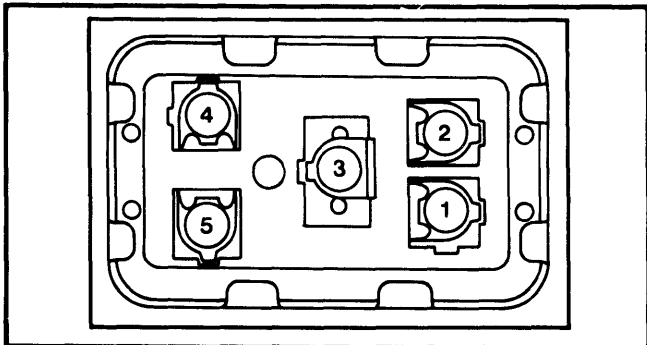

Fig. 6 Dual Pick-Up Start-Run Relay Terminal Locations

SYSTEM VOLTAGE CHECK

1) Remove coil secondary wire from distributor cap. Turn ignition switch "ON". Connect a special jumper wire momentarily from ignition coil negative terminal to ground, while holding secondary wire $\frac{1}{4}$ " from engine ground. See Fig. 7. A spark should jump to ground.

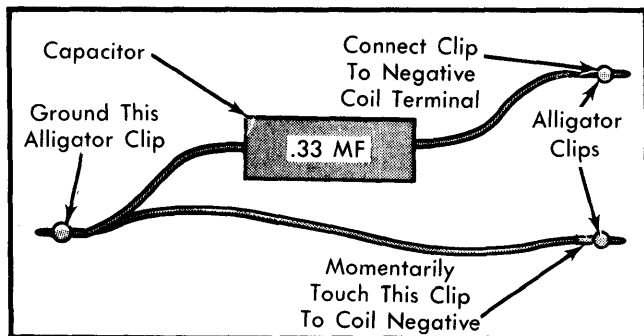

Fig. 7 Special Jumper Wire for Checking System Voltage

2) If spark was present, proceed to "Wiring Harness and Connector." If no spark was obtained, turn ignition switch "OFF". Disconnect 4-wire harness connector from electronic control unit.

3) Turn ignition switch "ON". Repeat step 1). If spark now results with connector removed, replace electronic control unit.

4) If no spark was obtained in step 3), measure voltage at coil positive terminal. It should be within 1 volt of battery voltage. If so, check for battery voltage at coil negative terminal. If you get battery voltage but no spark in step 3), replace ignition coil.

5) If no battery voltage was present at ignition coil positive terminal in step 4), replace starter relay and check wiring bet-

ween battery positive terminal and coil positive terminal. If continuity does not exist, replace ballast resistor and repeat Step 4).

WIRING HARNESS & CONNECTOR

Measure voltage across battery terminals, record this measurement. Turn ignition switch "OFF", then disconnect harness connector from control unit. Connect voltmeter negative lead to a good ground and then turn ignition "ON". Make checks as follows.

1) Connect voltmeter positive lead to control unit harness connector cavity 1. Reading should be battery voltage. If not, check and repair wires and components from harness connector cavity 1 back to battery. See Figs. 8 and 9.

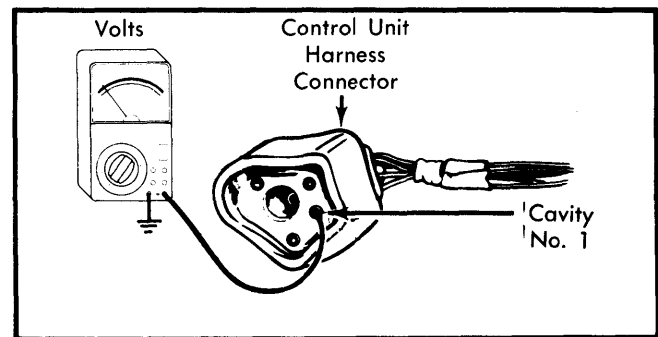

Fig. 8 Checking Voltage at Cavity No. 1

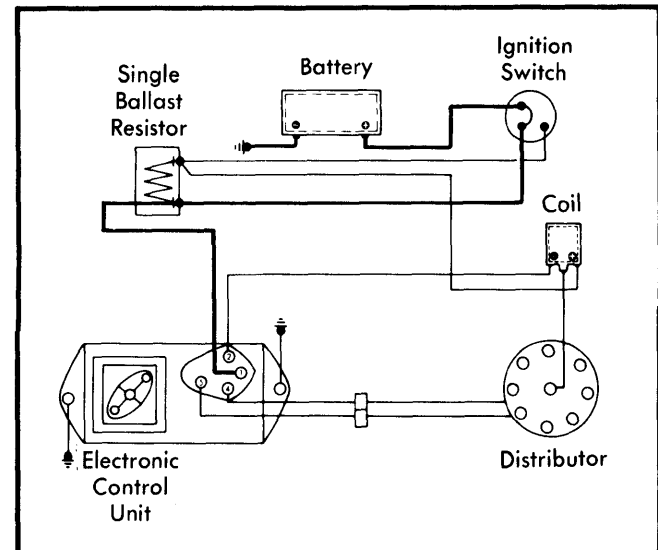

Fig. 9 Circuitry Checked if Cavity No. 1 Reading is Not to Specifications

2) With voltmeter negative lead still connected to ground, connect positive lead to harness connector cavity 2. Voltmeter should again read battery voltage. If reading is not to specification, check voltage at each connection (coil negative terminal, coil positive terminal, ballast resistor, ignition switch, etc.) back to battery. Repair wiring or replace components as necessary. See Figs. 10 and 11.

CHRYSLER CORP. ELECTRONIC IGNITION (Cont.)

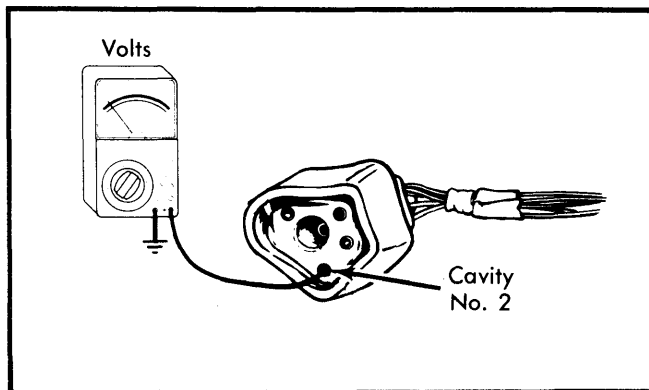

Fig. 10 Checking Voltage at Cavity No. 2

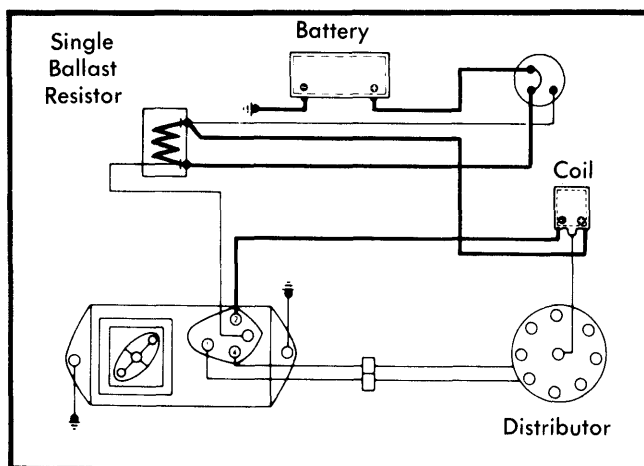

Fig. 11 Circuitry Checked if Cavity No. 2 Reading Is Not to Specifications

3) If reading jumped to battery voltage on positive side of ignition coil, check coil primary and secondary resistance. If coil is bad, replace it. Also check ballast resistor by disconnecting wires from resistor and then taking an ohmmeter reading across its 2 terminals. Resistance should be 1.12-1.38 ohms. If reading is not to specifications, replace ballast resistor. See Fig. 12.

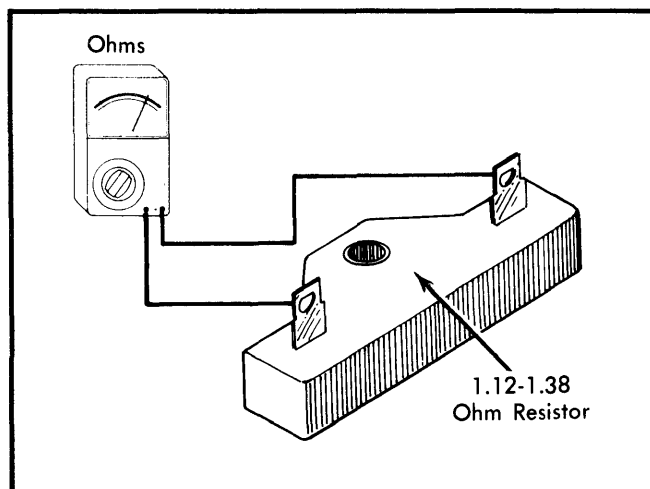

Fig. 12 Checking Ballast Resistor Resistance

DISTRIBUTOR PICK-UP COILS

1) Turn ignition switch "OFF". Disconnect control unit harness connector. Connect ohmmeter leads to cavities 4 and 5 of harness connector. See Fig. 13. Ohmmeter reading should be 150-900 ohms. If reading is not to specifications, make same check at 2-wire connector(s) leading to distributor. If readings at pick-up coils are now correct, start-run relay or harness from control unit to distributor is defective. If readings are still not correct, replace faulty pick-up coil assembly.

NOTE - On distributors with single pick-up coil assemblies, there will be only one 2-wire connector to check.

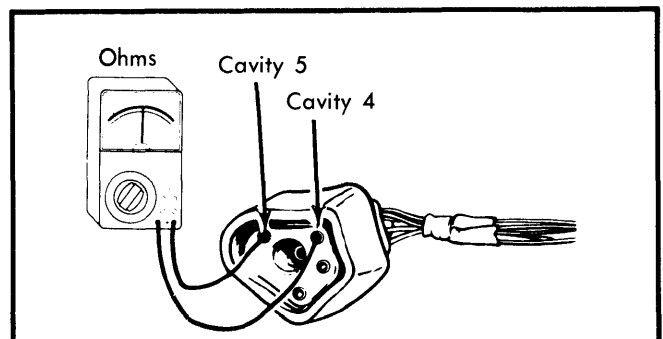

Fig. 13 Checking Resistance at Cavities No. 4 and 5 (Pick-Up Coil Resistance)

2) Connect one ohmmeter lead to a good ground (distributor housing). Connect other lead to either terminal of start pick-up coil distributor connector, then to either terminal of run pick-up coil connector. If ohmmeter shows a reading for either test, replace faulty pick-up coil and adjust air gap.

ELECTRONIC CONTROL UNIT GROUND CIRCUIT

1) Connect one ohmmeter lead to a good ground and other lead to control unit connector pin 5 (not cavity 5 of harness connector). Ohmmeter should show full continuity.

2) If not, make sure control unit is making good contact with ground at hold-down bolts. If it is, replace control unit.

CENTRIFUGAL ADVANCE CURVE

Install distributor in test stand. It is important that appropriate adapter for checking electronic type distributors be used. Adjust tester speed control to operate distributor at speeds called for in distributor tables. If advance is not according to specifications, replace distributor shaft assembly (shaft, reluctor sleeve, governor weights).

IGNITION COIL RESISTANCE

1) Coil is designed to operate with an external ballast resistor. When testing ignition coil for output and resistance, also make ballast resistor tests. See Fig. 12. Inspect coil for external cracks and arcing at same time.

2) To check coil primary resistance, isolate coil from rest of system. Connect ohmmeter leads to positive and negative primary terminals. To check secondary resistance, connect ohmmeter leads to coil negative terminal and coil tower.

3) If resistance readings are not to specifications, replace ignition coil.

CHRYSLER CORP. ELECTRONIC IGNITION (Cont.)

Resistance Specifications

Application	Ohms@70-80°F
Primary Resistance	
Prestolite	1.60-1.79
Essex	1.34-1.55
Secondary Resistance	
Prestolite	9400-11,700
Essex	9000-12,200
Single Ballast Resistor	
Resistor Resistance	1.12-1.38

OVERHAUL

DISASSEMBLY

- 1) Remove distributor cap, rotor and vacuum control unit. Remove reluctor. Some reluctors may be pulled off with fingers. If this is impossible, pry up from bottom with 2 screwdrivers. Be careful not to distort reluctor teeth.
- 2) Remove screws attaching lower plate to housing and lift out lower plate, upper plate and pick-up coils as an assembly. Do not attempt to remove distributor cap clamp springs.

3) Remove distributor drive collar retaining pin and slide collar off end of shaft. Use a file to clean burrs from around pin hole in shaft, and remove lower thrust washer. Push shaft up and remove it through top of distributor housing.

REASSEMBLY

- 1) Test operation of governor weights and inspect the weight springs for distortion. Lubricate governor weights. Inspect all bearing surfaces and pivot pins for roughness, binding, or looseness. Lubricate and install upper thrust washer on shaft and slide shaft into distributor housing.
- 2) Install lower thrust washer and original collar on lower end of shaft, and install retaining pin. If collar is not in good condition, replace it.
- 3) Install lower plate, upper plate, and dual pick-up coil assembly. Attach vacuum advance unit arm to pick-up plate and install attaching screws.
- 4) Position reluctor keeper pin into place on reluctor sleeve. Slide reluctor down reluctor sleeve and press firmly into place. Make sure keeper pin is in place. Lubricate felt pad in top of reluctor sleeve and install rotor.