

FORD ELECTRONIC ENGINE CONTROL III (EEC III)

Ford
Calif. Models with
5.0L (302") & 5.8L (351") W Engines

OPERATION

DESCRIPTION

Ford Electronic Engine Control III (EEC III) with 7200VV Feedback Carburetor is used on California light duty Ford models with 5.0L and 5.8L W engines.

The EEC system consists of an Electronic Control Assembly (ECA), several sensors located on the engine or in the various engine systems, special actuators governed by the ECA, and various connecting electrical and vacuum lines. This system adjusts the engine to the best settings for various conditions of load, speed, temperature and altitude by controlling the following functions:

- Ignition Timing
- Carburetor Air/Fuel Ratio
- Engine Speed At Idle
- Exhaust Gas Recirculation (EGR) Flow Rate
- Secondary (Thermactor) Air Flow Rate
- Fuel Evaporation Canister Purging

ELECTRONIC CONTROL ASSEMBLY (ECA)

The ECA is a solid-state, micro-computer consisting of a processor assembly and a calibration assembly. This unit is located in the passenger compartment under the instrument panel, to the left of the steering column. The ECA is the "brain" of the EEC system.

Processor Assembly – The processor assembly is housed in an aluminum case and contains circuits designed to:

- Continuously sample input signals from the sensors.
- Calculate the proper spark advance, air/fuel ratio, EGR flow and thermactor air flow.
- Send out control signals to adjust spark timing, air/fuel ratio, EGR flow, thermactor air mode, evaporation canister purge and idle speed.

The processor assembly also provides a continuous reference voltage of 9.0 volts to the sensors.

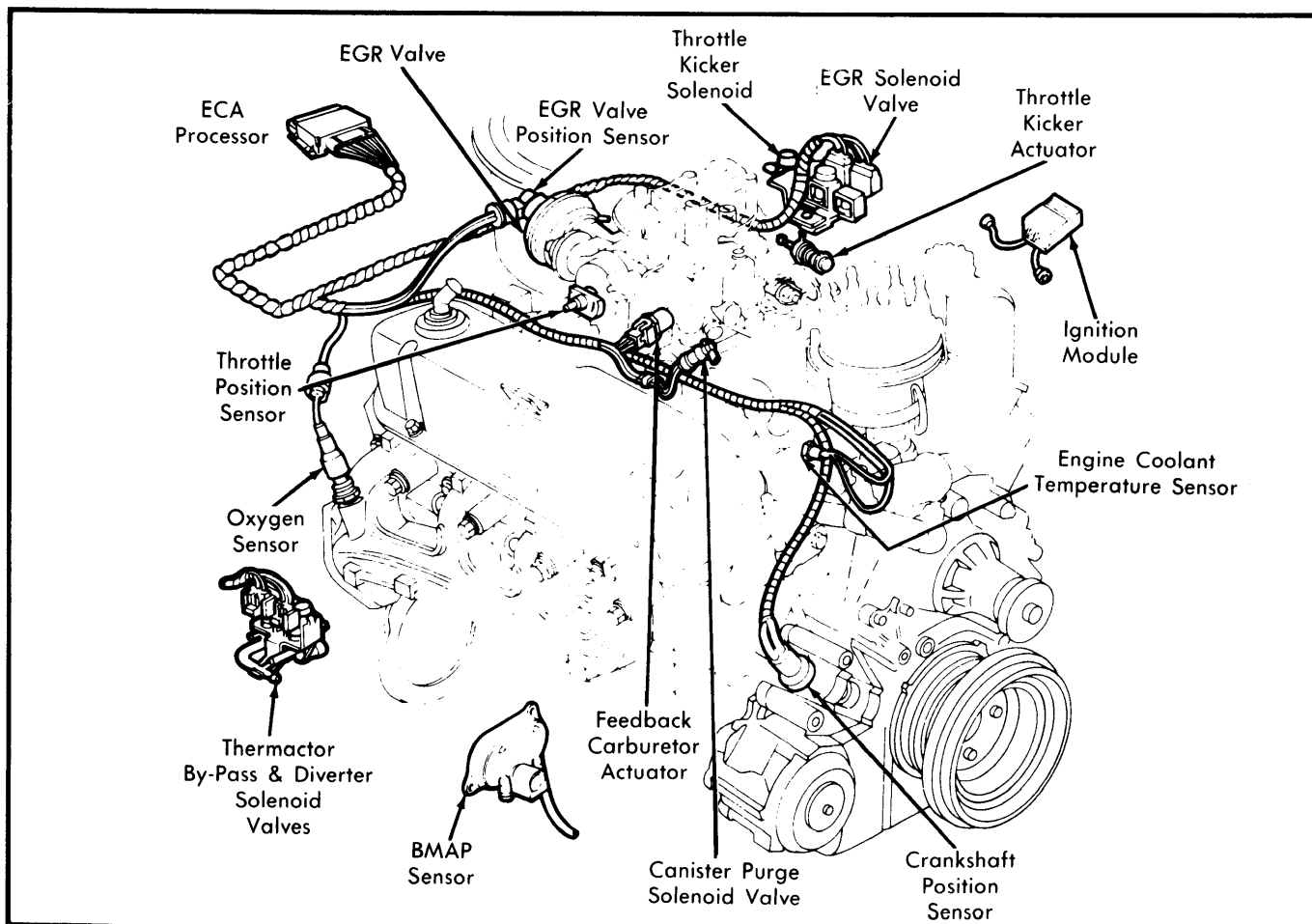

Fig. 1 Electronic Engine Control Component Locations

FORD ELECTRONIC ENGINE CONTROL III (EEC III) (Cont.)

Calibration Assembly — The calibration assembly is contained in a black plastic housing which is attached to the top of the processor assembly. It contains the "memory" and programming used by the processor assembly and is capable of:

- Providing operating information for that particular vehicle, for use by the processor assembly.
- Recalling information from its memory when required.

Power Relay — Activated by the ignition switch to supply battery voltage to the EEC. Attached to the lower right side of the ECA mounting bracket. Also protects ECA from possible damage due to reversed voltage polarity.

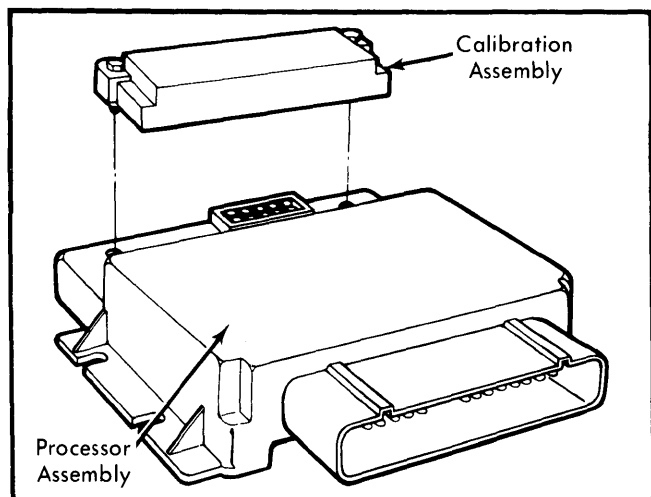

Fig. 2 EEC Electronic Control Assembly (ECA)

LIMITED OPERATION STRATEGY (LOS) MODE

The LOS mode functions during engine start, or upon failure of the ECA detected by a "safeguard" circuit in the ECA. This mode allows continued vehicle operation (with reduced performance) until repairs can be made. In this mode the actuator functions are set as follows:

- Ignition Module Timing: Minimum spark advance (10° BTDC).
- Feedback Carburetor Actuator (FBCA): Locked at last controlled position. On startup, the FBCA is driven full rich and then slightly lean.
- Exhaust Gas Recirculation (EGR): No EGR.
- Thermactor Air (TAB): Bypass (dump) position.
- Canister Purge (CANP): Canister sealed, no purge.
- Throttle Kicker (TK): Low RPM idle.

SENSORS

Engine Coolant Temperature (ECT) Sensor — Installed in heater outlet fitting at front of intake manifold near right valve cover, the ECT sensor converts coolant temperature to an electrical signal for the ECA. The brass sensor housing contains a thermistor (a resistor that changes value according to temperature). The ECA is able to determine engine coolant temperature by the resistance value of the sensor.

Throttle Position (TP) Sensor — The TP sensor is a potentiometer. The resistance of the sensor varies with throttle opening. The ECA applies a reference voltage to the sensor and the

resultant sensor output voltage allows the ECA to determine throttle position (closed throttle, part throttle or wide open throttle). This information is used by the ECA in determining the proper amount of spark advance, EGR flow, air/fuel ratio and the proper thermactor air mode.

NOTE — The throttle position (TP) sensor mounting holes are slotted to permit rotational adjustment. If sensor is replaced, it must be correctly positioned or erroneous throttle information will be sent to the ECA.

Crankshaft Position (CP) Sensor — To provide the EEC system with an accurate timing reference (when pistons reach 10° BTDC), the crankshaft vibration damper is fitted with a 4-lobe "pulse ring".

As the crankshaft rotates, the pulse ring interrupts a magnetic field at the tip of the CP sensor (mounted on right front of engine). When the field is interrupted, an output signal is generated and sent to the ECA. The ECA uses these signals to determine the exact position of the crankshaft. From the frequency of the pulses, the ECA can determine engine RPM. By knowing these two factors, the ECA can determine the appropriate ignition timing advance required for best engine operation.

NOTE — Once the CP sensor is installed, no field adjustment is necessary.

Exhaust Gas Oxygen (EGO) Sensor — Installed in the exhaust manifold, the EGO sensor provides the ECA with the oxygen concentration of the exhaust gas.

The EGO sensor monitors the oxygen concentration of the exhaust gas and generates an output of .6 to 1.1 volts when detecting a rich exhaust gas mixture, and less than .2 volts when detecting a lean mixture. The constantly changing voltage signal is sent to the ECA for analysis.

CAUTION — The EGO sensor resistance CANNOT be measured by connecting an ohmmeter directly to its output lead. Sensor damage will result if this is attempted.

Barometric and Manifold Absolute Pressure (BMAP) Sensor — The BMAP sensor is actually two sensors combined into one assembly. This sensor monitors the absolute value of the intake manifold pressure and atmospheric pressure.

NOTE — Manifold absolute pressure is the difference between barometric pressure and manifold pressure.

Changes in atmospheric pressure and intake manifold pressure are converted into electrical signals and sent to the ECA. The signals are used to adjust spark advance and EGR rate to fit engine conditions.

EGR Valve Position (EVP) Sensor — The EVP sensor is attached to the EGR valve and provides an electrical signal to the ECA that indicates EGR valve position. Using the input from this and other sensors, the ECA can regulate EGR flow by activating or deactivating a pair of solenoid valves.

FORD ELECTRONIC ENGINE CONTROL III (EEC III) (Cont.)

THROTTLE KICKER SYSTEM

The throttle kicker system consists of a Throttle Kicker Solenoid (TKS) and a Throttle Kicker Actuator (TKA). The system is designed to increase engine RPM when the A/C is on, at high altitude, and when coolant temperature is above or below a specific range.

With A/C "ON", the ECA energizes the TKS allowing intake manifold vacuum to reach the TKA. The TKA is positioned on the carburetor against the throttle lever. With vacuum applied, the TKA will increase engine RPM for increased cooling and smoother idle. The TKA is also energized during engine warm-up or if an engine overheat condition exists.

EXHAUST GAS RECIRCULATION (EGR) SYSTEM

The EGR system used with EEC-III has 3 major components: an EGR valve and sensor assembly, an EGR cooler, and a 2-solenoid EGR control assembly.

Utilizing engine manifold vacuum to operate the EGR valve, the ECA controls EGR gas flow. When EGR valve is open, exhaust gas from exhaust manifold is directed into the intake

manifold and becomes part of the combustion cycle, helping to reduce NOx emissions levels.

EGR Valve and Sensor Assembly – The EGR valve is mounted to the intake manifold under the carburetor. The valve controls EGR flow through a pintle valve and seat. An EGR valve position sensor (EVP) is attached to the valve and provides an electrical signal to the ECA indicating EGR valve position. The EGR valve, unlike standard EGR valves, has no opening to observe pintle valve movement. The EGR valve and position sensor are serviced as individual units.

Dual EGR Control Solenoids – EGR valve flow rate is controlled by two solenoid valves mounted on the left valve cover. Proper control of vacuum needed to operate the EGR valve requires two types of solenoid valves:

- A vent valve, which is normally open; that is, the outlet port is normally connected to the inlet port when the solenoid is not energized.
- A vacuum valve, which is normally open; that is, the outlet port is normally blocked when solenoid is not energized.

Utilizing input from the various sensors, the ECA directs the vacuum and vent solenoids to: (1) Increase EGR flow by applying vacuum to the EGR valve, (2) Maintain the EGR flow by

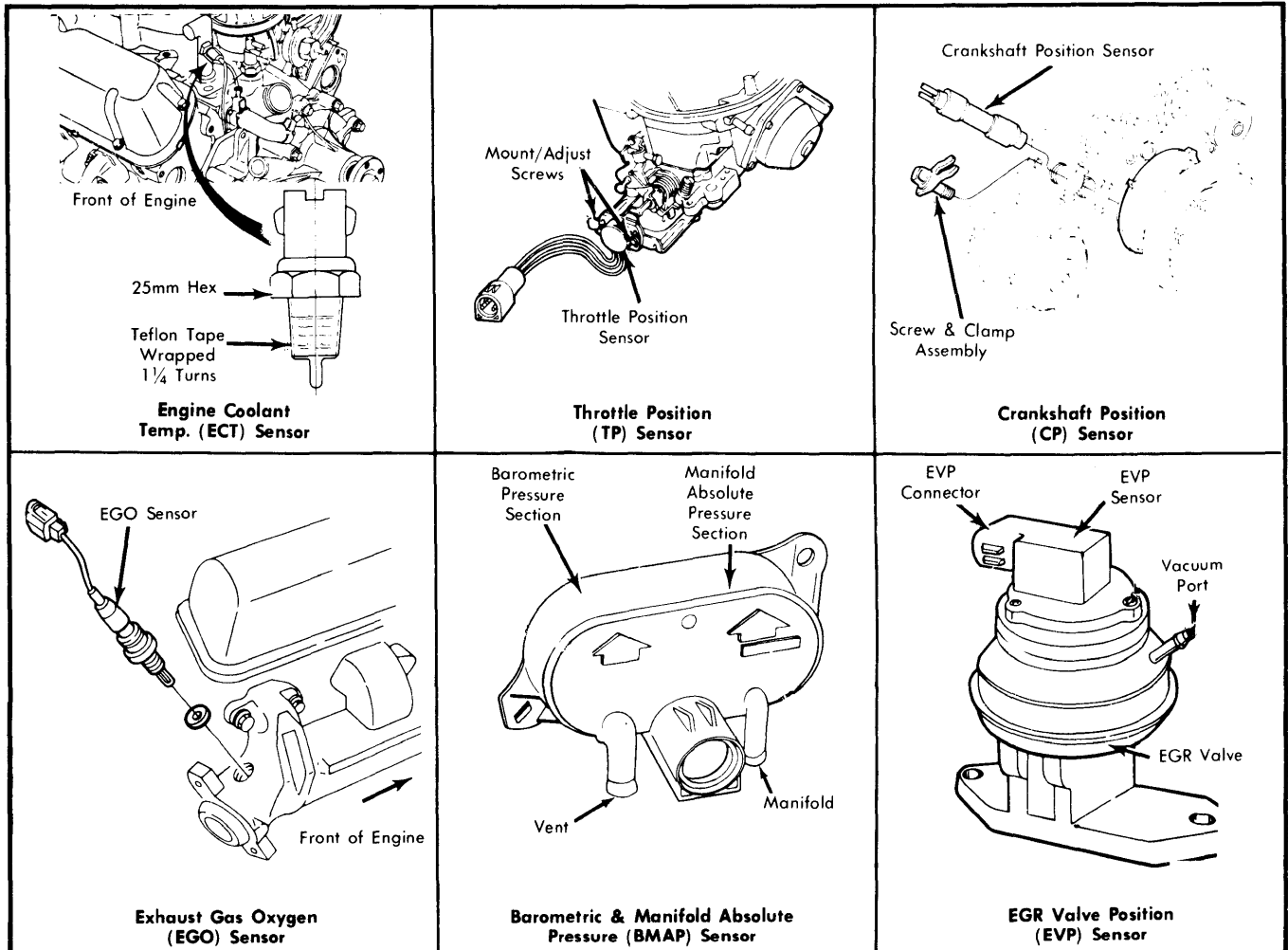

Fig. 3 Electronic Engine Control Sensors

FORD ELECTRONIC ENGINE CONTROL III (EEC III) (Cont.)

trapping vacuum in the system, and (3) Decrease EGR flow by venting the system to the atmosphere.

EGR Cooler Assembly — An EGR gas cooler is used to reduce EGR gas temperature, thus providing improved flow characteristics, better engine operation and EGR valve durability.

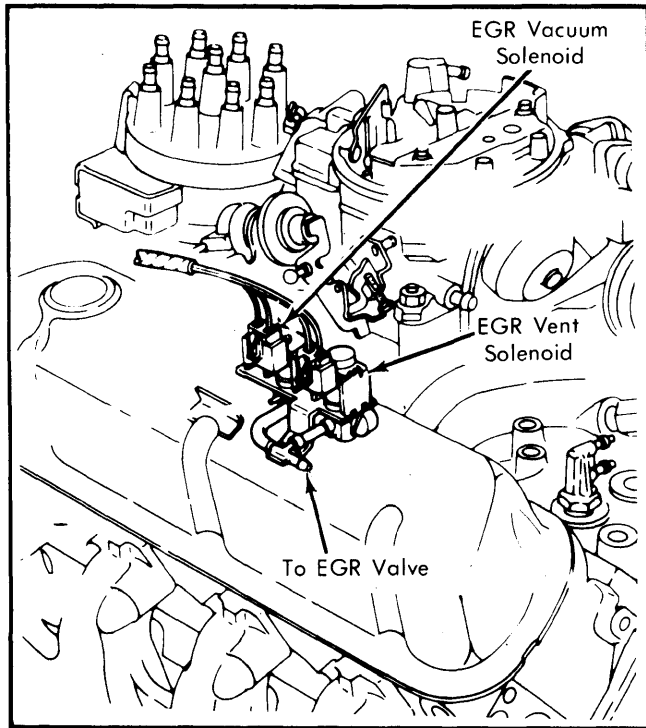

Fig. 4 Dual EGR Control Solenoids

THERMACTOR AIR SYSTEM

The Thermactor Air System used with EEC-III consists of the following components: an air supply pump, Thermactor Bypass/Diverter valve, dual Thermactor solenoids, 2 check valves, and a 3-way converter (referred to as COC/TWC).

The efficiency of the catalytic converter is dependent upon temperature and the chemical makeup of the exhaust gases. Air must be provided to the COC catalyst for the oxidation of HC and CO byproducts of the TWC catalyst.

Air Supply Pump — This belt driven pump provides the source of air to be controlled by the bypass/diverter valve as directed by the ECA. The air pump does not have a pressure relief valve, this function being controlled by the bypass/diverter valve.

Bypass/Diverter Valve — Air from the air pump has three possible routes through the bypass/diverter valve:

- Downstream air (air injected into three-way catalyst).
- Upstream air (air injected into exhaust manifold).
- Bypass (air bypassed to atmosphere).

The proper routing for thermactor air is determined by the ECA based on engine coolant temperature versus time curve and other sensor data. During normal coolant temperature operation the air is normally directed downstream. The air is bypassed when the closed throttle time exceeds a set time value, or if the time between the Exhaust Gas Oxygen

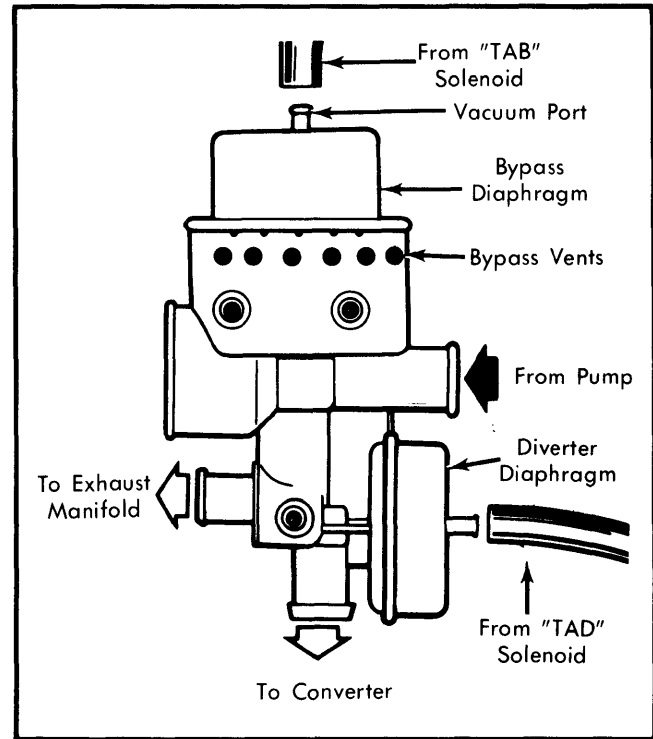

Fig. 5 Thermactor Air System By-Pass/Diverter Valve

lean/rich sensor exceeds a set time value. The air will also be bypassed during wide open throttle mode or during extended closed throttle operation.

During engine warm-up the thermactor air will be routed upstream. This is to help remove excessive amounts of HC and CO produced during the warm-up period.

Dual Air Control Solenoids — The bypass/diverter valve operation is controlled by two solenoid valves: Thermactor Air Bypass (TAB) valve, and Thermactor Air Diverter (TAD) valve. The valves are mounted on top of the right hand fender apron.

The TAB solenoid valve controls manifold vacuum to the bypass portion of the bypass/diverter valve, which in turn controls whether air from thermactor pump is bypassed to the atmosphere (solenoid de-energized) or routed to control the diverter valve (solenoid energized).

The TAD solenoid valve controls manifold vacuum to the diverter portion of the bypass/diverter valve, which in turn controls which direction (upstream or downstream) thermactor air is routed. In the de-energized position, air is routed downstream. In the energized position, air is routed upstream.

Exhaust Check Valve — Two exhaust check valves are used in the EEC II Thermactor system to prevent reverse flow of exhaust gases in the event of system malfunction. One check valve is located between the bypass/diverter valve and the exhaust port drillings, and the other valve between the catalytic converter and the bypass/diverter valve.

Three-Way Catalytic Converter (COC/TWC) — This is a dual catalytic converter consisting of two converters in one shell, with a mixing chamber between the two. Each converter

FORD ELECTRONIC ENGINE CONTROL III (EEC III) (Cont.)

is composed of a ceramic "honeycomb" coated with catalyst material.

The front, or "three-way catalyst" (TWC) converter acts on exhaust gases as they arrive from the engine. As gases flow from the TWC converter to the rear, or "conventional oxidation catalyst" (COC) converter, they mix with air from the thermactor pump injected into the mixing chamber. This air is required for proper oxidation of HC and CO in the COC converter.

FEEDBACK CARBURETOR ACTUATOR (FBCA)

The FBCA controls air/fuel ratio on signal from the ECA by adjusting the position of a vacuum bleed metering rod in the carburetor. This actuator is not a solenoid but a combination motor and leadscrew. The leadscrew changes the rotary motion of the motor to a linear (in and out) motion of the actuator shaft.

The FBCA actuator shaft can be set by ECA signal to any position between fully retracted and fully extended. When the actuator shaft is fully extended, the vacuum bleed metering rod is seated, permitting the slightly rich mixture to enter the engine unchanged.

When the actuator shaft is retracted, the metering rod bleeds vacuum from the control vacuum chamber into the fuel bowl. This lowers the air pressure in the fuel bowl, which leans out the air/fuel mixture.

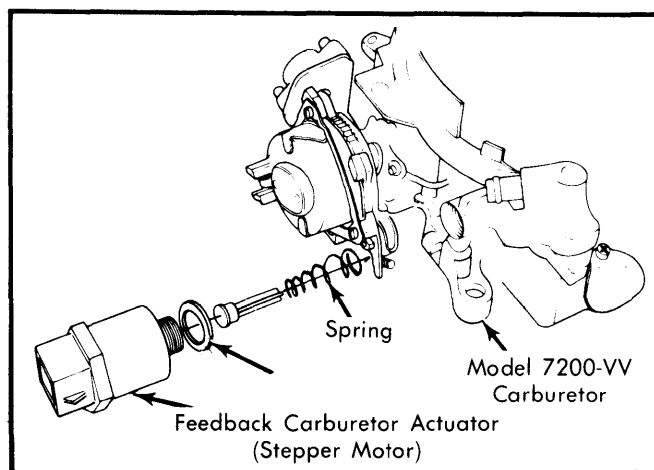

Fig. 6 EEC III Feedback Carburetor Actuator

CANISTER PURGE SYSTEM

Canister Purge (CANP) Solenoid — This solenoid is a combination solenoid and valve. Located in the line between the intake manifold purge fitting and the carbon canister, the CANP solenoid controls the flow of vapors from the canister to the intake manifold during various engine operating modes. The valve is opened and closed by a signal from the ECA.

DURA-SPARK III IGNITION SYSTEM

The EEC-III system uses a Dura-Spark III module (Brown grommet where wires emerge) and a Dura-Spark II ignition coil. A resistance wire is also used in the primary circuit.

Distributor — The EEC distributor eliminates conventional mechanical and vacuum advance mechanisms. All timing is controlled by the ECA, which is capable of firing the spark plug at any point within a 50° range depending on calibration. This increased spark capability requires greater separation of adjacent distributor cap electrodes to prevent cross-fire.

Bi-Level Rotor and Distributor Cap — Both the rotor and cap have upper and lower electrode levels. As the rotor turns, one of the high voltage electrode pickup arms aligns with one spoke of the distributor cap center electrode plate, allowing high voltage to pass from the plate, through the rotor to the terminal on the cap and on to the spark plug.

The numbers molded into the top of the distributor cap are wire identification numbers. Due to the unique design of the cap and rotor, the wires ARE NOT arranged in the cap in firing order. The outer ring of numbers is for 5.8L engine and the inner ring is for the 5.0L engine. Actual firing order for 5.0L is 1-5-4-2-6-3-7-8 and for 5.8L is 1-3-7-2-6-5-4-8.

NOTE — Do not attempt to remove any silicone coating from the rotor lower electrode blades or from the distributor cap electrodes (including the center plate electrodes). With age, this silicone compound has the appearance of being a contaminant of the cap and electrodes. This condition is normal and will not affect the performance.

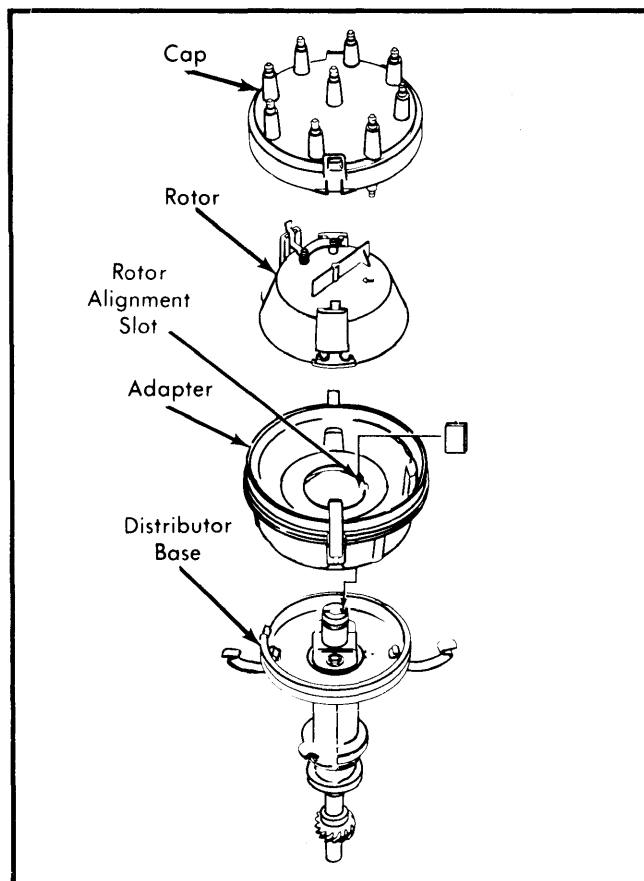

Fig. 7 EEC III Ignition Distributor Assembly

1981 Exhaust Emission Systems

FORD ELECTRONIC ENGINE CONTROL III (EEC III) (Cont.)

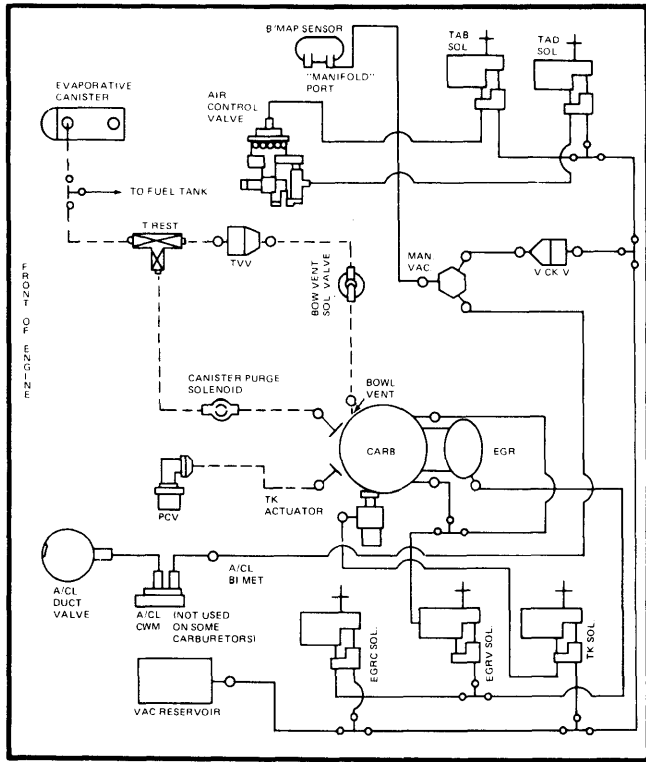

Fig. 8 Typical EEC III Vacuum Schematic

DIAGNOSIS & TESTING

NOTE - Due to the complexity of the EEC III system, full testing cannot be done unless a special tester is used. Instructions for testing come with the tester, which is available from Owatonna Tool Co. However, some checks can be made using regular shop equipment. These checks are outlined in the following procedures.

TESTING NOTES & CAUTIONS

NOTE - No repairs or adjustments can be made to the ECA components. If diagnosis shows Processor or Calibration units are not functioning properly, they must be replaced.

CAUTION - Shorting the wiring harness across a solenoid valve can burn out circuitry in the ECA that controls the solenoid valve actuator.

CAUTION - The EEC system contains transistors which CANNOT tolerate excessive voltage surges or transient voltage. Never try to jump-start the vehicle with 24 volts.

CAUTION - The Exhaust Gas Oxygen (EGO) sensor resistance CANNOT be measured by connecting an ohmmeter directly to its output lead. Sensor damage will result if this is attempted.

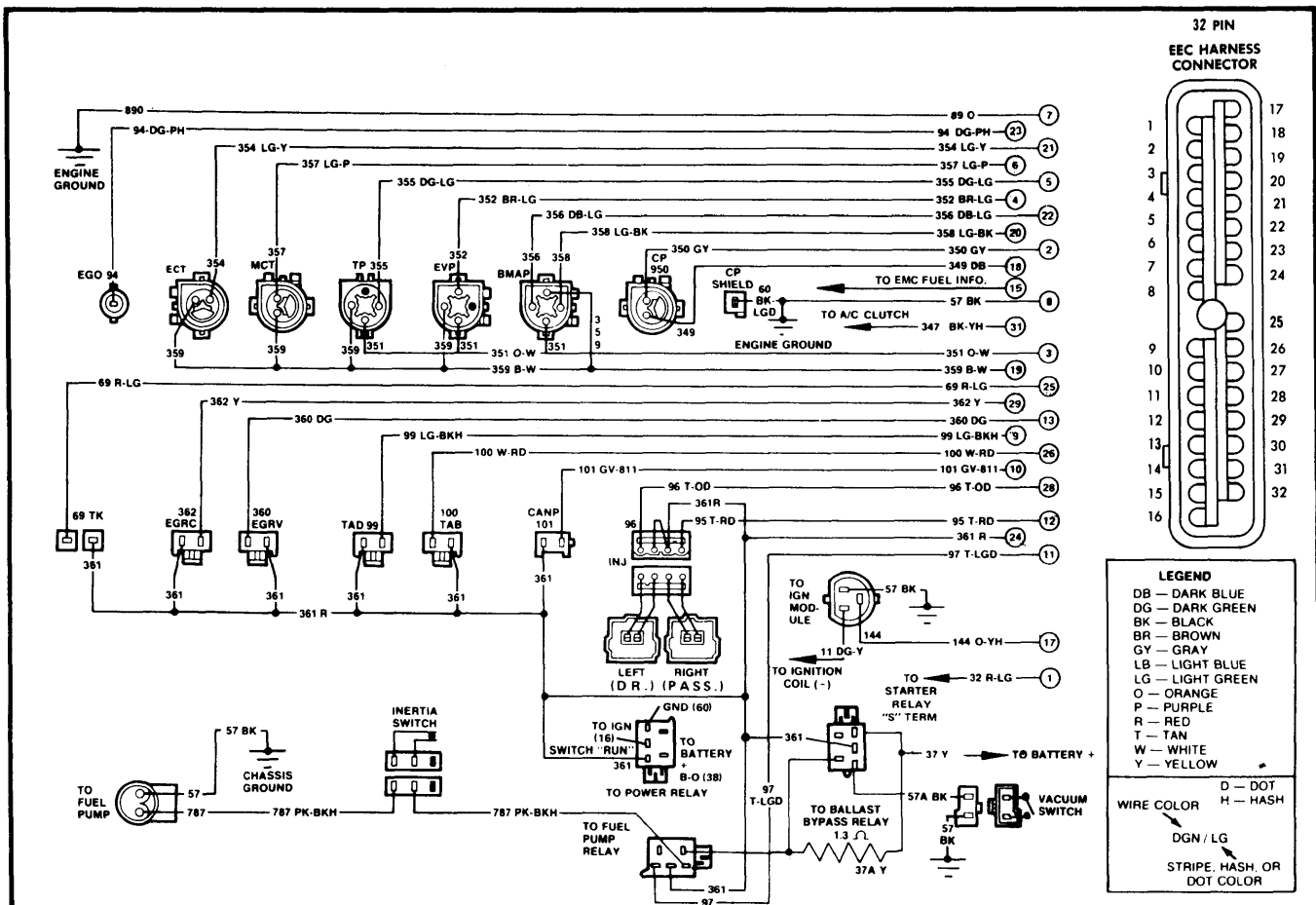

Fig. 9 Electronic Engine Control System Wiring Diagram

FORD ELECTRONIC ENGINE CONTROL III (EEC III) (Cont.)

BASIC EEC TROUBLE SHOOTING

- 1) Perform basic fuel system and ignition system checks, to ensure there is gas and spark.
- 2) Remove air cleaner assembly and inspect all vacuum and pressure hoses for proper connection to fittings, or any broken, cracked or pinched conditions.
- 3) Inspect EEC sub-system harness for proper connections to EGR solenoid valves. Red wire to both, yellow wire to vacuum solenoid and green wire to vent solenoid.
- 4) Check for any loose or detached connectors or broken or detached wires. Ensure all terminals are completely seated.
- 5) Check for partially broken or frayed wires at connectors or any shorting between wires. Also clean up any corrosion detected.
- 6) Inspect sensors for evidence of physical damage.
- 7) Repair items as required. Replace air cleaner.
- 8) Check vehicle electrical system. Check for full battery charge and check battery cable connections for tightness.
- 9) Inside passenger compartment, check to make sure the power relay is securely attached and making a good ground connection.
- 10) Use an ohmmeter to check resistance of the system sensors and solenoids. If any component fails to meet specifications, replace it. Be sure to disconnect component from system before measuring resistance.

OXYGEN SENSOR TEST

- 1) With engine at operating temperature but stopped, disconnect oxygen sensor connector. Start engine and run on high step of fast idle cam for 1 minute.

2) Connect voltmeter between ground and sensor, then depress carburetor control vacuum regulator (CVR) rod for 10 seconds. Voltage should be more than 0.5 volts.

3) Run engine at fast idle for 1 minute with PCV valve disconnected. Measure oxygen sensor voltage. Voltage should be less than 0.5 volts.

4) If oxygen sensor does not function as described, retest. If voltage readings are still incorrect, replace sensor. Tighten sensor to 27-33 ft. lbs.

REMOVAL & INSTALLATION

BMAP SENSOR

Removal — Disconnect wiring harness from BMAP sensor. Disconnect vacuum hose, remove retaining nuts, and remove sensor.

Installation — Position sensor and tighten retaining nuts. Connect vacuum hose to "Manifold" port. Do not connect any hose to "Vent" port. Connect wiring harness.

CANISTER PURGE SOLENOID VALVE

Removal — Remove air cleaner. Disconnect 2-wire connector and 2 vacuum hoses from solenoid. Remove valve.

Installation — Connect hose from manifold to nipple at end of valve. Connect hose from "T" to nipple toward middle of valve. Position valve so end with wires faces upward, then connect wiring and install air cleaner.

CRANKSHAFT POSITION (CP) SENSOR

Removal — Disconnect both sensor connectors. Remove sensor retaining clamp and pull sensor carefully out of holder.

Installation — Clean holder, then insert sensor fully (clamping surface about .025" from holder surface). Install retaining

EEC III COMPONENT RESISTANCE VALUES

Component	Wire Colors	Resistance (Ohms)
Crankshaft Position (CP) Sensor	Gray-Dk Blue	100-640
Engine Coolant (ECT) Sensor	Lt Grn/Yel-Blk/Wht	1100-8000
Air Charge Temperature (ACT) Sensor	Lt Grn/Ppl-Blk/Wht	1700-60,000
Throttle Position (TP) Sensor		
Closed Throttle	Org/Wht-Blk/Wht	3000-5000
Closed Throttle	Dk Grn/Lt Grn-Blk/Wht	550-1100
Wide Open Throttle	Dk Grn/Lt Grn-Blk/Wht	More than 2100
EGR Control Solenoid	Red-Yel	More than 30
EGR Vent Solenoid	Red-Dk Grn	More than 30
TK Solenoid	Red-Red/Lt Grn	More than 45
TAB Solenoid	Red-Wht/Red	45-90
TAD Solenoid	Red-Lt Grn/Blk	45-90
Fuel Pump Relay	Red-Tan/Lt Grn	More than 40
By-Pass Ballast Resistor		Less than 3
Feedback Motor (FBCA)	⊙	32-150

⊙ — Measured from center terminal (above blank) to each other terminal.

FORD ELECTRONIC ENGINE CONTROL III (EEC III) (Cont.)

clamp and tighten to 70-100 INCH Lbs. Route wires up water pump and under spark plug wires along manifold to right of carburetor.

ELECTRONIC CONTROL ASSEMBLY

Removal — 1) Remove 10 mm retaining bolt and remove harness connector. Remove 2 bracket nuts, then remove gasket around connector.

2) From inside passenger compartment, remove 2 screws holding ECA to bracket. Slide out ECA and remove 2 screws to lift off calibration assembly.

Installation — 1) Attach calibration assembly with 2 screws. Slide ECA into bracket, engaging clip in ECA flange. Position connector surface through firewall, then install 2 mounting screws.

2) Install gasket carefully and replace bracket mounting nuts. Install connector and tighten retaining bolt to 40 INCH Lbs.

ENGINE COOLANT TEMPERATURE (ECT) SENSOR

Removal — Disconnect wiring and remove sensor with 25 mm socket.

Installation — Install sealing tape on threads of sensor. Install sensor, tightening to 8-18 ft. lbs. Reconnect wiring.

OXYGEN SENSOR

Removal — Allow exhaust manifold to cool. Disconnect wiring and remove sensor with crow's foot socket or special tool (T79P-9472-A).

Installation — Clean mounting surface and install sensor with fingers. Use tool to tighten sensor until compression washer crushes (27-33 ft. lbs.), then connect wiring.

EGR VALVE POSITION SENSOR

Removal — Disconnect wiring connector. Remove 3 fasteners at perimeter of sensor. Lift sensor and "O" ring seal. Cover valve to prevent foreign material from entering.

Installation — Clean top of valve and "O" ring groove. Lubricate "O" ring with silicone grease, then install in groove. Install sensor and secure with 3 self-tapping screws. Connect wiring.

TAB/TAD SOLENOID ASSEMBLY

Removal — Remove wiring connector from solenoids. Remove vacuum source hose at "T" and disconnect both solenoid hoses. Remove bolts from underneath fender and remove valve assembly.

Installation — Install assembly and tighten screws. Connect vacuum source hose to "T". Connect air by-pass hose to TAB solenoid (toward front of engine), then connect air diverter hose to TAD solenoid (toward firewall). Install wiring connectors.