

AIR INJECTION SYSTEMS – AIR PUMP TYPE

All Models

DESCRIPTION

The air injection systems, used on many applications (may vary according to engine and equipment), are designed to reduce carbon monoxide and hydrocarbon emissions. This is done by injecting fresh air at critical points in the exhaust manifold to burn those gases which passed through the combustion cycle. System consists of an air pump with integral filter, diverter/bypass valve, check valve(s), external or internal injection tubing and connecting hoses. Some Ford and all Chrysler models use additional valves, depending on applications. They are explained below.

OPERATION

AIR PUMP

The air pump uses an eccentric (off-center) vane to draw in fresh air, compress it and pass it on through the system. The pump is belt driven. *Fig. 1.*

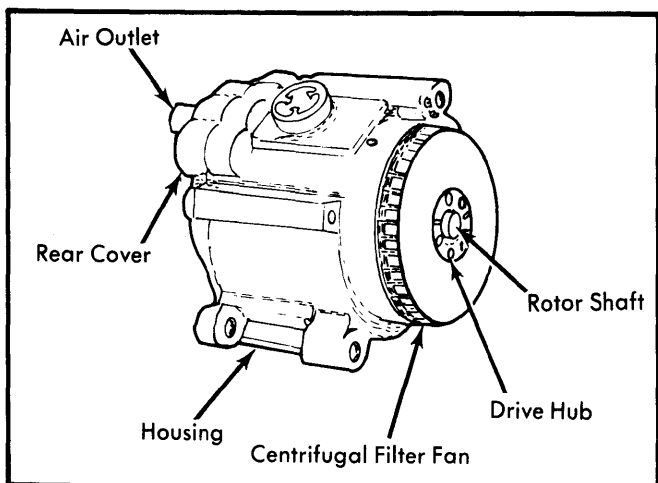

Fig. 1 Typical Air Injection Pump

DIVERTER VALVE

After the air leaves the air pump, it goes immediately into the diverter valve. This valve serves to prevent backfire by stopping air injection flow during periods of high increase in manifold vacuum (such as during deceleration). The diverter valve will dump the air supply to the atmosphere for the first few seconds of deceleration. Most diverter valves also have a pressure relief valve built in which bleeds off excessive air pump pressure to prevent damage to the system.

Diverter valves used on many applications are similar to the one shown in *Fig. 2.*

Ford & Jeep Timed Bypass Valve – This is a normally-open valve. During normal operation, vacuum is equalized on both sides of the diaphragm. Spring pressure holds the valve open, allowing fresh air to the exhaust. On deceleration, manifold

vacuum pulls the diaphragm so that air is directed to the atmosphere. A small orifice in the diaphragm will allow the pressure to quickly equalize again. See *Fig. 3.*

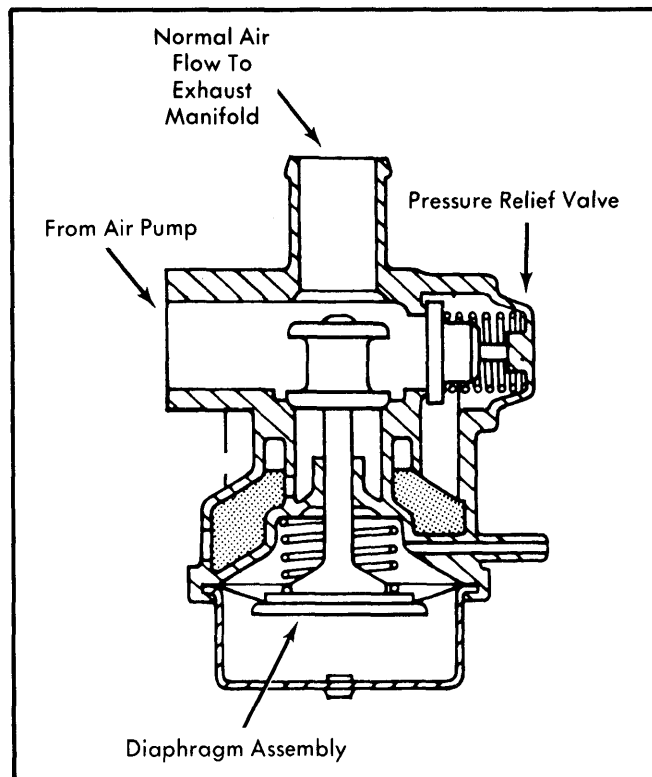

Fig. 2 Typical Diverter Valve Chevrolet, GMC & Chrysler Corp.

Ford Normally-Closed Bypass Valve – When no vacuum is applied, all air pump air is diverted to the atmosphere to protect the converter. When vacuum is received, air then passes to the exhaust ports.

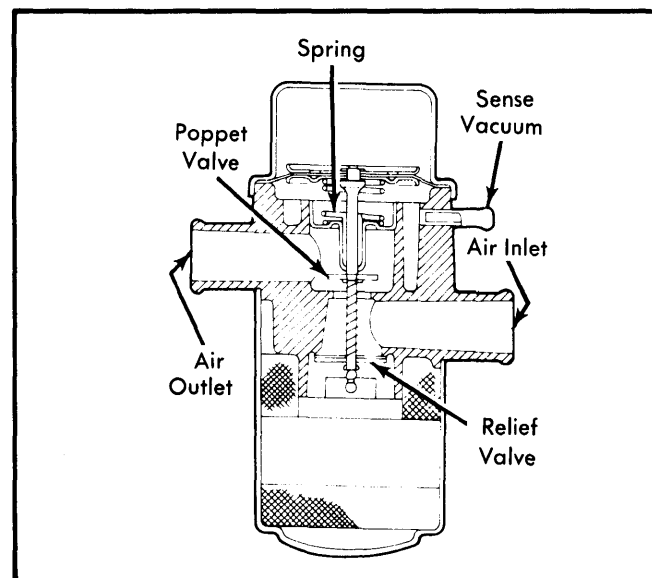

Fig. 3 Typical Diverter Valve Ford & Jeep (Bypass Valve)

AIR INJECTION SYSTEMS – AIR PUMP TYPE (Cont.)

Ford & Jeep Timed & Vented Bypass Valve – Valve operation is similar to that of the timed valve described earlier. When vacuum signal is 8" Hg or more, the valve will continuously vent air pump air to the atmosphere. See Fig. 4.

**AIR SWITCHING VALVE
CHRYSLER CORP. ONLY**

This valve is used to switch the injection air from the exhaust ports to a point downstream after engine warm-up. A bleed hole in the switching valve allows a small portion of the air to be injected at the exhaust ports at all times to assist in reducing emissions.

**POWER HEAT CONTROL VALVE
CHRYSLER CORP. ONLY**

Located between the right exhaust manifold and exhaust pipe, this valve is vacuum operated and directs a majority of the exhaust gas flow through the left side exhaust manifold until engine temperature reaches a pre-determined point. After that temperature is reached, gas flows through both manifolds.

INJECTION MANIFOLD

The injection manifold on many applications is an external tubing system, mounted to the exhaust manifold with air delivery ports for each exhaust port. It is through this manifold that air pump air reaches the exhaust system. Some applications have an internal air injection system which is specially drilled passages in the intake manifold which carry the air pump air to the exhaust ports. This eliminates the external tubing.

CHECK VALVE

The check valve is a one-way flow valve. It prevents air from the exhaust manifold from backing up through the system and reaching the air pump. The check valve will be found either in the tubing leading to the injection manifold or as an integral part of the manifold.

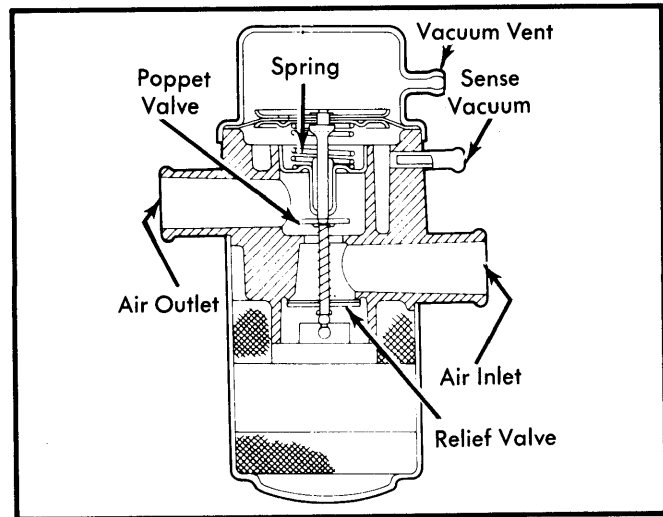

Fig. 4 Ford & Jeep Timed & Vented Bypass Valve

**IDLE VACUUM VALVE
(FORD ONLY W/CAT. CONVERTER)**

This valve is used on Ford models which have a catalytic converter. The air injection system on these models is also tied into the EGR system. See Fig. 6.

Operating in conjunction with a vacuum delay valve, the idle vacuum valve provides backfire control, full-time idle air dump, cold temperature catalyst protection and cold EGR lockout. On long idle, the air dump prevents high underbody temperatures in the exhaust system. During cold engines, the valve prevents air injection and EGR operation until the catalyst and engine are warm.

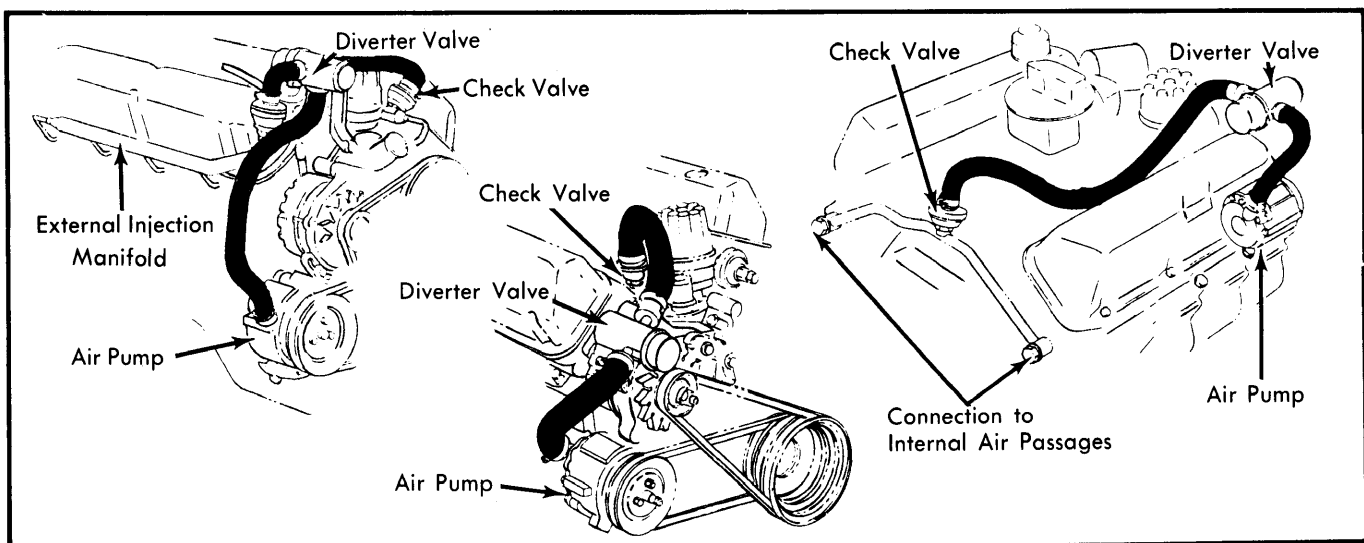

Fig. 5 Typical Air Injection System Installation Configurations

AIR INJECTION SYSTEMS – AIR PUMP TYPE (Cont.)

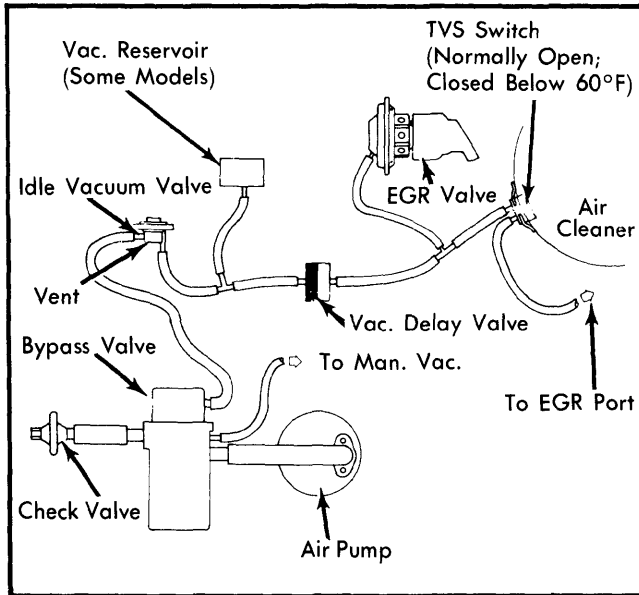

Fig. 6 Schematics of Ford Air Injection System with Idle Vacuum Valve

TROUBLE SHOOTING

Excessive Belt Noise – Loose pump drive belt or seized pump.

Excessive Pump Noise – Leak in hose, loose hose, hose touching other engine parts, diverter valve or by-pass valve failure, check valve failure, pump mounting loose, pump or impeller damaged.

No Air Supply – Loose drive belt, leak in hose or hose fitting, diverter valve or by-pass valve failure, check valve failure, pump failure.

Exhaust Backfire – Incorrect engine tune-up, engine vacuum leaks, faulty diverter valve or check valve.

NOTE – Proper operation of the Air Injection System is dependent upon proper engine tune-up. See individual car models for specifications and procedures.

TESTING

Diverter Valve Test – Check valve by accelerating engine and allowing throttle to close rapidly; a momentary rush of air should be noted at diverter air outlet.

Check Valve Test – To check operation of this valve, remove air supply hose from pump at distribution manifold. With engine operating listen for exhaust leakage at check valve which is connected to distribution manifold.

MAINTENANCE

Approximately every 15,000 miles, air injection system components should be checked for proper operation and condition. No regular parts replacement schedule is required. Service is limited to replacement of air pump filter if it becomes clogged.

Centrifugal Fan Filter – To replace, remove drive belt, pulley mounting bolts, and pulley. Break off remaining portions of centrifugal fan filter from pump hub, being careful that fragments do not enter air intake hole. Install new filter by drawing it on with the pulley and pulley bolts. Do not attempt to hammer or press filter on.

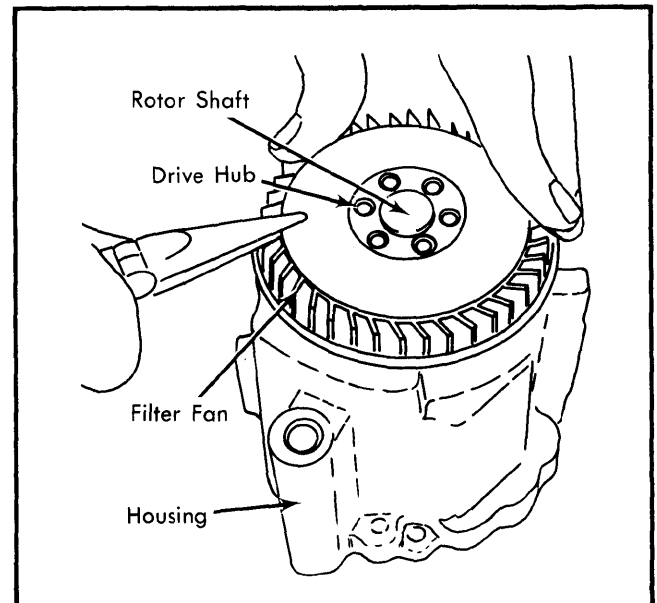

Fig. 7 Removing Centrifugal Fan Filter from Air Injection Pump with Pulley Removed

NOTE – After new filter is installed, it may squeal during operation until its outside diameter has worn in. This may require 20 to 30 miles of operation.

CAUTION – If engine or engine compartment is to be cleaned with steam or high pressure detergent, centrifugal filter fan should be masked off to prevent liquids from entering air pump.

Exhaust Emission System Cleaning – DO NOT attempt to clean diverter valve. Do not blow compressed air through check valve.

Air Pump Overhaul – Overhaul of air pump is not recommended since internal components of pump are not serviceable. However, certain service items can be replaced as follows:

Pump Exhaust Tube Replacement – Remove by placing tube in a vise or use a suitable pair of pliers to pull tube with a twisting motion. Insert new tube into hole and tap in with a block of wood to protect tube. Approximately 3/8" of tube should extend above cover.