

ROCHESTER 1ME SINGLE BARREL

CARBURETOR APPLICATION

CHEVROLET & GMC

Application	Rochester Carb. No.
4.8L (292")	
Federal	
C, K, & P20/30	17081009
C & K20/30	17081309
Calif.	
P30	17081329

CARBURETOR IDENTIFICATION

The carburetor model identification is stamped on a vertical portion of the float bowl, adjacent to the fuel inlet nut. If replacing float bowl, follow manufacturer's instructions contained in service package so that the identification number can be transferred to the new float bowl.

DESCRIPTION

The Rochester model 1ME carburetor is a single bore downdraft type carburetor using a triple venturi in conjunction with a plain tube nozzle. This model carburetor incorporates an electrically activated integral automatic choke system. The choke vacuum diaphragm is mounted externally to carburetor air horn and is connected to thermostatic coil lever through a connector link. An electrically actuated idle stop solenoid and dual throttle return springs are used on all models.

ADJUSTMENT

HOT (SLOW) IDLE RPM

See appropriate article in *TUNE-UP SERVICE PROCEDURES*.

IDLE MIXTURE

See appropriate article in *TUNE-UP SERVICE PROCEDURES*.

COLD (FAST) IDLE RPM

See appropriate article in *TUNE-UP SERVICE PROCEDURES*.

FLOAT LEVEL

- 1) Remove air horn. Hold float pin firmly in place. Push down on end of float arm against top of float needle. See Fig. 1.
- 2) With gasket removed, use a depth or "T" scale to measure distance from top of casting to index point at toe of float.
- 3) If adjustment is needed, gently bend float arm up or down. Do not force needle against needle seat to avoid damage.
- 4) Install new gasket, replace air horn. Start engine and check for leaks.

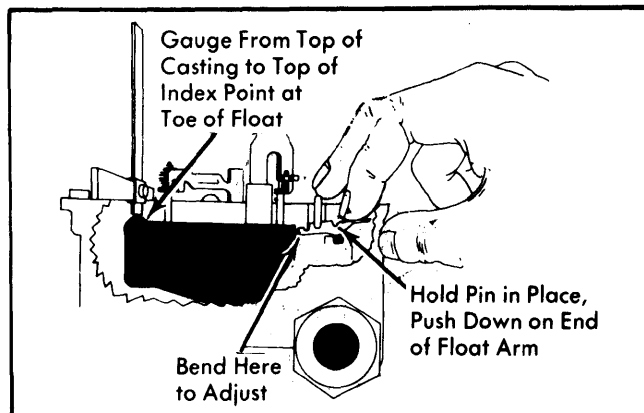

Fig. 1 Adjusting Float Level

METERING ROD ADJUSTMENT

- 1) Remove air horn and gasket. Hold throttle valve wide open. Push down on metering rod against spring tension. See Fig. 2.
- 2) Slide metering rod out of slot in holder and remove from main metering jet.
- 3) Back out idle stop solenoid. Hold throttle valve in fully closed position.
- 4) Press down on power piston. Swing metering rod holder over flat surface of bowl casting next to bore.
- 5) Measure specified clearance between rod holder and carburetor surface. Measurement can be made using a drill or pin gauge.
- 6) If adjustment is needed, gently bend holder arm up or down. Recheck clearance.
- 7) Reassemble carburetor. Install new air horn-to-body gasket. Check for leaks.

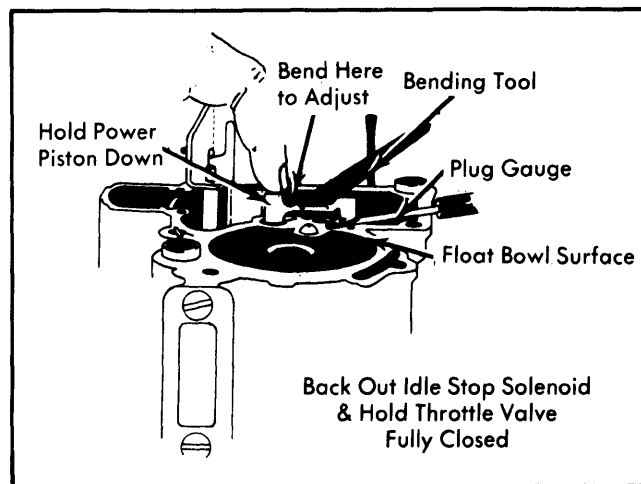

Fig. 2 Adjusting Metering Rod

ROCHESTER 1ME SINGLE BARREL (Cont.)

CHOKE COIL LEVER

- 1) Place cam follower on HIGHEST step of fast idle cam. Hold choke valve closed. See Fig. 3.
- 2) If adjustment is correct, specified plug gauge should be able to pass through hole in lever and enter hole in casting. Bend connector link to adjust.

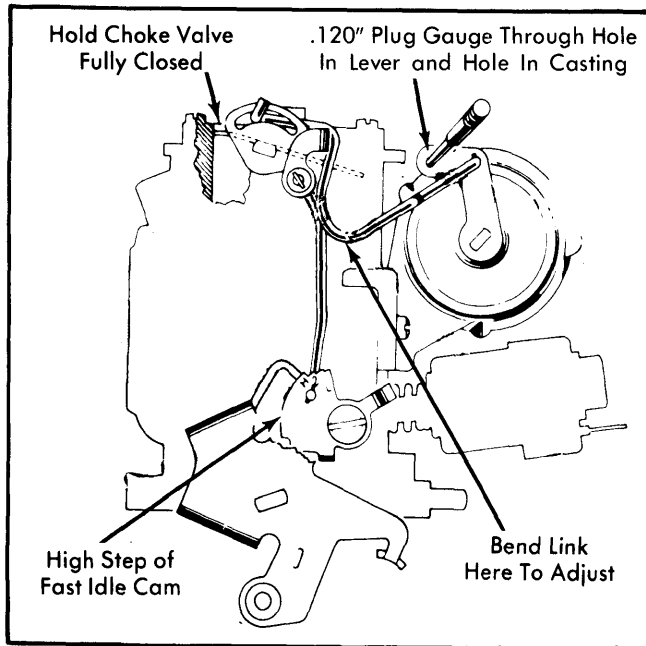

Fig. 3 Adjusting Choke Coil Lever

CHOKE COIL ROD
(FAST IDLE CAM)

- 1) Make sure fast idle speed is correctly set. Place fast idle cam follower on SECOND step of fast idle cam, against HIGHEST step. See Fig. 4.

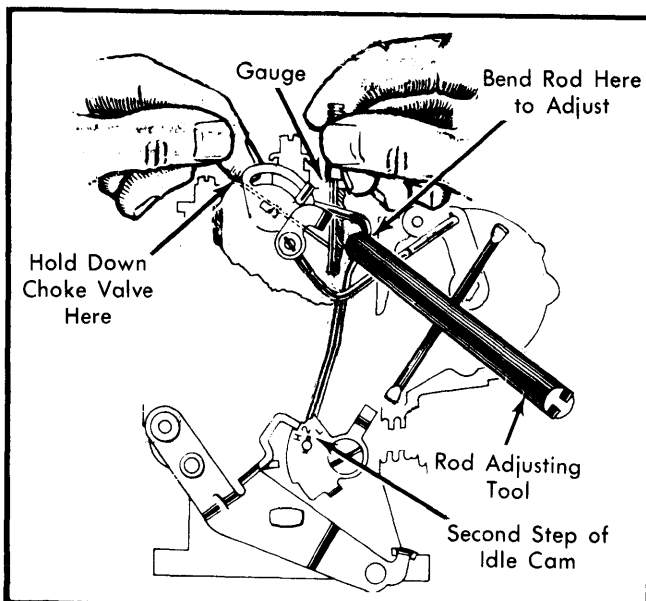

Fig. 4 Adjusting Choke Coil Rod

- 2) Apply light closing pressure to choke valve. Measure specified clearance between lower edge of choke valve and air horn wall. Measurement can be made with a specified drill or pin gauge. To adjust, bend fast idle cam rod.

AUTOMATIC CHOKE

NOTE — Choke coil cover uses rivets in place of retaining screws. If necessary to remove choke coil cover, refer to Disassembly and Reassembly procedures in this Section.

VACUUM BREAK

- 1) Place cam follower on HIGHEST step of fast idle cam. Use outside vacuum source and apply enough vacuum to seat diaphragm. See Fig. 3.
- 2) Diaphragm plunger should be IN and seated. If used, bucking spring should be fully compressed.
- 3) Push up on choke coil lever: Rod should be snug in end of diaphragm plunger slot. On models equipped with delay feature, cover purge bleed hole in vacuum break end cover with masking tape.
- 4) Measure specified clearance between lower edge of choke valve and air horn wall. Measurement can be made with a specified drill or pin gauge. See Fig. 5.
- 5) To adjust, bend "U" shaped portion of vacuum diaphragm connector link. Remove masking tape. Check linkage for binding.

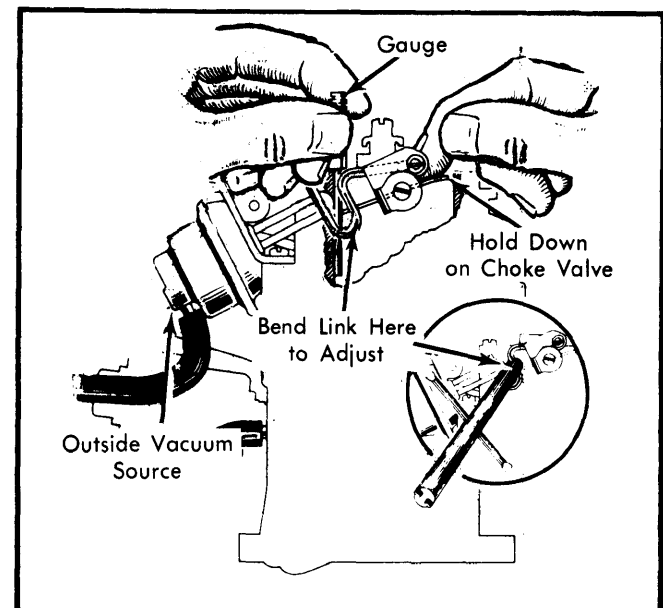

Fig. 5 Adjusting Vacuum Break

CHOKE UNLOADER.

- 1) Install choke coil in housing and index properly.

NOTE — If choke is warm, cool down to point where choke valve will close fully.



ROCHESTER 1ME SINGLE BARREL (Cont.)

2) Hold throttle valve wide open. Measure specified clearance between lower edge of choke valve and air horn wall.

3) Measurement can be made using a specified drill or pin gauge. If adjustment is required, bend choke unloader tang to achieve proper clearance.

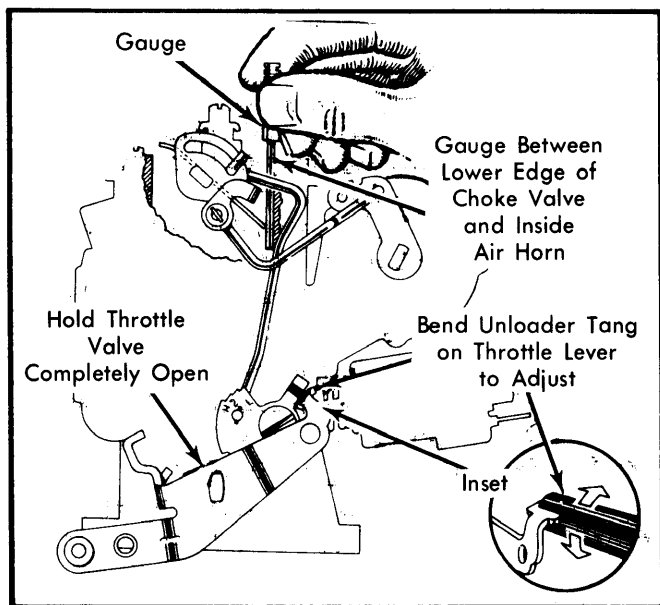

Fig. 6 Adjusting Choke Unloader

OVERHAUL

DISASSEMBLY

Air Horn – 1) Place carburetor on suitable stand to prevent damage to throttle valve. Pull off vacuum break diaphragm hose. Remove diaphragm assembly from air horn (2 attaching screws).

2) Slide diaphragm plunger stem from choke lever link. Do not attempt to remove screw that retains vacuum break lever to choke shaft. This screw is installed with thread-locking compound and should not be removed unless choke shaft replacement is required.

NOTE – Do not remove choke housing unless replacement of housing is necessary.

3) Remove fast idle cam. Remove choke rod from choke coil lever. Remove 3 choke coil housing attaching screws from float bowl.

NOTE – Two screws have lock washers. Screw facing choke housing has tapered head for locating housing.

4) If necessary to remove choke coil cover, drill rivet heads from cover retainer using a .159" (No. 21) drill. Remove cover retainer and cover. Carefully remove remaining pieces of rivets from housing.

5) Remove (4) remaining air horn-to-float bowl screws and lockwashers (3 long and 1 short). Carefully remove air horn by lifting and twisting back towards choke housing. Disengage choke coil lever link from choke coil lever at choke housing.

6) Turn air horn upside-down. If required, remove choke valve and choke shaft by removing screw retaining vacuum break lever to choke shaft. Be sure to apply Loctite or suitable torque retaining compound to this screw upon assembly. Now remove (2) choke valve attaching screws. Remove choke valve and shaft from air horn.

NOTE – Choke valve screws are staked in place. File off staking for removal and restake during assembly. Use care not to bend choke shaft when staking screws.

Float Bowl – 1) Remove air horn gasket. Lift upward on float hinge pin to extract float assembly from bowl. Remove hinge pin from float arm. Withdraw float needle from seat. Disconnect accelerator pump and power piston actuator lever from end of throttle shaft by removing lever attaching screw. Hold down power piston while removing lever. Power piston and metering rod assembly may now be removed.

2) Remove lower end of power piston link from actuator lever by rotating until tang on rod slides out of notch in lever. Remove actuator lever from lower end of accelerator pump link in same manner. Push down on accelerator pump and remove actuator link by rotating until tang on rod is aligned with slot on pump plunger lever. Remove the link.

3) Remove pump assembly from float bowl. Remove pump return spring and power piston spring from float bowl. Extract "T" guide and pump discharge spring. Invert bowl and collect pump discharge ball and idle tube. Remove main metering jet from bottom of fuel bowl. Remove float needle seat and gasket. Idle stop solenoid can now be removed. Remove fuel inlet nut and gasket, filter and relief spring.

Throttle Body – Invert float bowl on bench and remove two throttle body-to-bowl attaching screws. Remove gasket. No further disassembly of throttle body is necessary unless idle mixture needle is damaged or idle channels need cleaning. If necessary to remove idle mixture needle, cut tang from plastic limiter cap. Do not install replacement.

NOTE – Due to close tolerance fit of throttle valve in bore of throttle body, do not remove throttle valve or shaft.

NOTE – California models have seals built into float bowl to seal the power piston drive rod and pump lever to prevent escape of fuel vapors to the atmosphere. Remove these seals and retainer prior to immersing float bowl in carburetor cleaner.

CLEANING & INSPECTION

- Use a regular carburetor cleaning solution. Soak components long enough to thoroughly clean all surfaces and passages of foreign matter.
- Do not soak any components containing rubber, leather or plastic.
- Remove any residue after cleaning by rinsing components in a suitable solvent.
- Blow out all passages with dry compressed air.

1981 Rochester Carburetors

ROCHESTER 1ME SINGLE BARREL (Cont.)

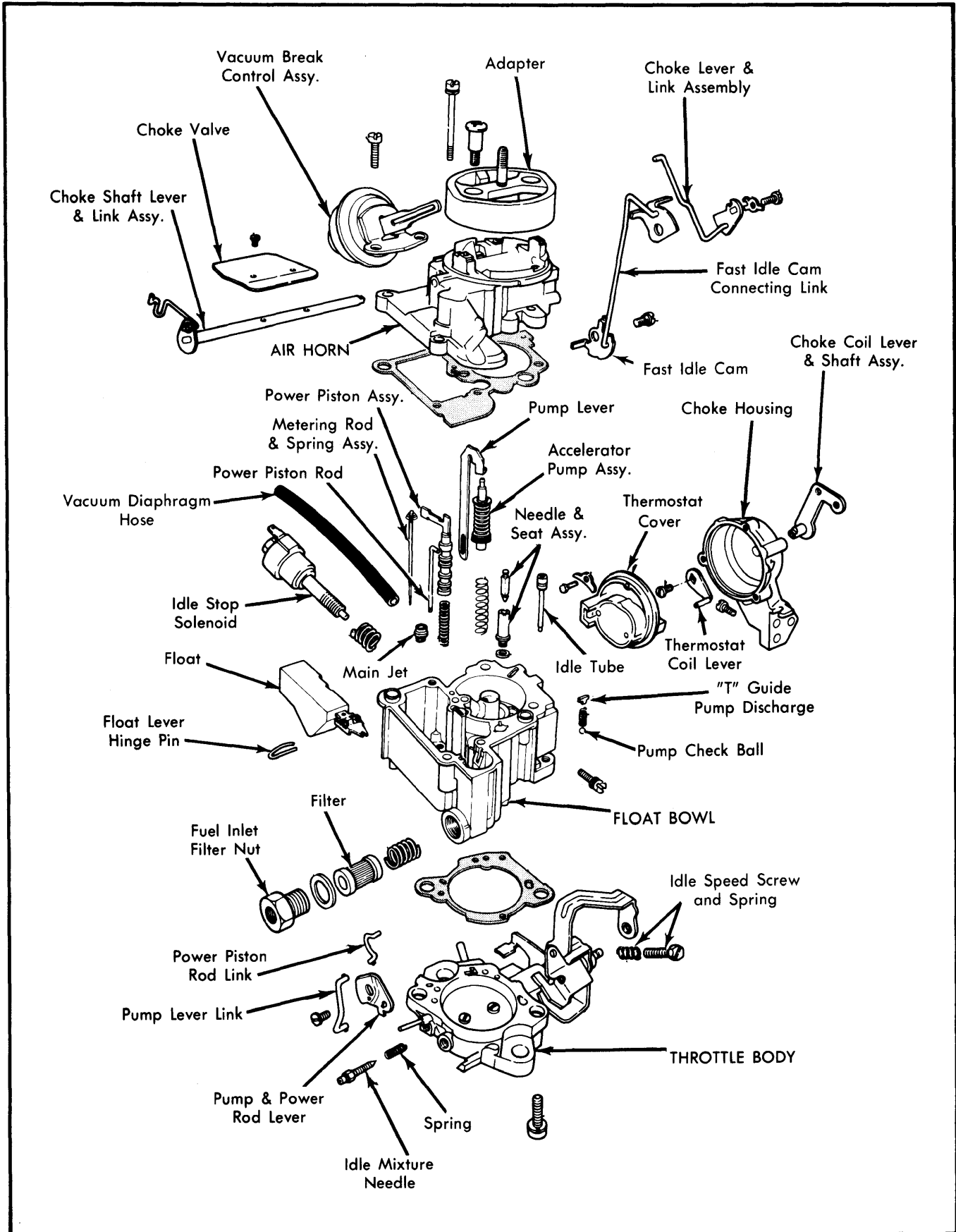

Fig. 7 Exploded View of Rochester Model 1ME Single Barrel Carburetor

ROCHESTER 1ME SINGLE BARREL (Cont.)

REASSEMBLY

NOTE — Use new gaskets and seals. Make sure that new gaskets fit correctly and that all holes and slots are punched through and correctly located.

To reassemble carburetor, reverse disassembly procedure noting the following:

1) Adjust float level and metering rod before installing air horn. All other adjustments are made with carburetor assembled.

2) Install metering rod with spring above power piston.

3) Thermostatic spring in idle compensator must hold valve closed after installation. Replace unit if spring is bent or distorted. Do not attempt to straighten or adjust spring.

4) Use two tapered head screws for mounting and locating diaphragm bracket. Install and tighten air horn screws evenly and in sequence shown in Fig. 8.

NOTE — If choke coil cover was removed, it will be necessary to install replacement rivets supplied in service kit. Do not use a gasket between choke housing and cover, as direct contact is needed to ground electric coil housing.

5) Place fast idle screw on high step of fast idle cam. Install choke coil cover, aligning notch in cover with raised boss on housing cover flange. Install self-tapping screws and tighten.

NOTE — When torquing carburetor after removal, tighten bolts in a clockwise direction to 198 INCH lbs. When retorquing at recommended intervals, retorque to 144 INCH lbs. maximum.

CAUTION — Do not use a gasket between choke housing and electric coil. Coil is grounded through housing.

6) Install vacuum diaphragm hose to diaphragm tube and connect to vacuum extension on bowl.

NOTE — When installing carburetor on intake manifold, install insulator, then carburetor. Tighten 2 nuts to 36 INCH lbs., then tighten nuts to 18 ft. lbs.

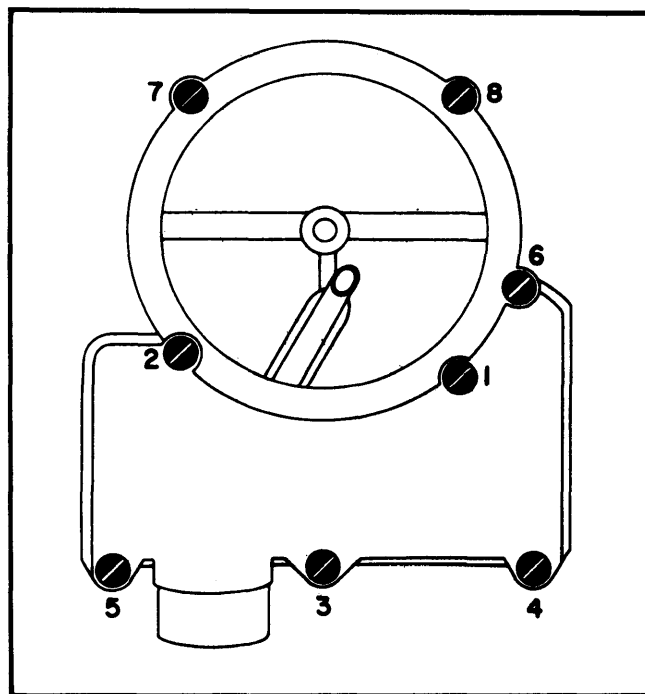

Fig. 8 Air Horn Tightening Sequence

CARBURETOR ADJUSTMENT SPECIFICATIONS

Application	Float Level Setting	Metering Rod Setting	Choke Coil Lever Setting	Auto. Choke Setting	Choke Coil Rod Setting	Vacuum Break Setting	Choke Unloader Setting
17081009	11/32"	.090"	.120"275"	.400"	.520"
17081309	11/32"	.090"	.120"275"	.400"	.520"
17081329	11/32"	.090"	.120"275"	.400"	.520"