

MOTORCRAFT MODEL 2150 2-BARREL

CARBURETOR APPLICATION

FORD

Application	Ford Part No.	
	Man. Trans.	Auto. Trans.
4.2L (255") Federal	E1TE-BVA	E1TE-CSA
5.0L (302") Federal	E1UE-GA, E1TE-BVA	E1TE-CRA, E1TE-CNA, E1TE-CKA, E1TE-CLA
Without A/C	E1UE-GA	E1TE-CPA, E1TE-CMA
With A/C	E1UE-GA	E1TE-CPA, E1TE-CMA
5.8L (351") M Federal	E1TE-BFA, E1TE-CFA	E1TE-CHA, E1TE-CDA, E1TE-BGA
Calif.	E1TE-CEA	E1TE-CCA
High Alt.	E1TE-BHA	E1TE-BJA, E1TE-BFA
5.8L (351") W Federal	E1UE-KA	
6.6L (400") Federal	E1TE-CBA, E1TE-BYA	E1TE-BYA
Calif.	E1TE-BZA	E1TE-CAA

JEEP

Application	Jeep Code No.	
	Man. Trans.	Auto. Trans.
5.0L (304") Federal	DMJ2	DA2J
Hilly Terrain	DM2A	
6.0L (360") Federal	RHM2	RHA2

CARBURETOR IDENTIFICATION

Ford Motor Co. — A carburetor identification tag is attached to carburetor. The tag contains part number prefix and suffix. Basic part number for all carburetors is 9510. A design change code (if any) is also stamped on the tag. An assembly date code (year, month and day) is also stamped on the tag.

Jeep — A carburetor identification tag is attached to carburetor. The tag contains the Jeep carburetor code number. An assembly date code (year, month and day) is also stamped on the tag.

DESCRIPTION

Motorcraft 2150 carburetors have 2 main assemblies: the air horn and main body. Air horn contains choke plate, fuel bowl vent, and hot idle compensator. Main body houses throttle plate, accelerator pump assembly, float assembly, power valve and fuel bowl. Each bore contains main and boost venturis, main fuel discharge, and accelerator pump discharge orifices.

On some applications, booster venturis contain variable high speed bleed control system, which allows control of air/fuel mixture for improved high speed operation and low speed responses.

Vehicles sold for high altitude use (above 4000 ft.) contain an altitude compensator. This circuit compensates for thinner air by metering an additional amount of air into the air/fuel mixture, preventing an over-rich situation. An automatic device (aneroid) reacts to atmospheric pressure and overrides the compensation feature at lower altitudes.

ADJUSTMENT

HOT (SLOW) IDLE RPM

See appropriate article in TUNE-UP SERVICE PROCEDURES.

VACUUM THROTTLE KICKER (DECCEL THROTTLE MODULATOR)

See appropriate article in TUNE-UP SERVICE PROCEDURES.

IDLE MIXTURE

See appropriate article in TUNE-UP SERVICE PROCEDURES.

COLD (FAST) IDLE RPM

See appropriate article in TUNE-UP SERVICE PROCEDURES.

ACCELERATOR PUMP STROKE

Accelerator pump stroke has been preset at the factory. Additional holes are provided for different engine applications. For normal operations, accelerator pump rod should be in the inner hole of pump lever. Install connecting rod to specified hole of overtravel lever. See Fig. 1.

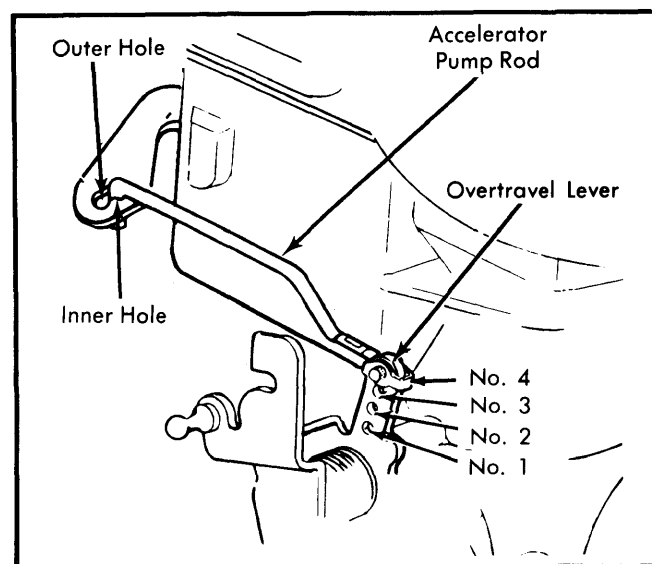

Fig. 1 Accelerator Pump Stroke

FLOAT LEVEL (DRY SETTING)

NOTE — Dry float setting is preliminary adjustment only. Final adjustment must be made after carburetor is installed on vehicle.

MOTORCRAFT MODEL 2150 2-BARREL (Cont.)

With air horn removed, raise float by depressing float tab until fuel inlet needle is lightly seated. Measure distance from top of main body (gasket removed) to flat portion of free end of float. If adjustment is necessary, carefully bend float tab.

NOTE — Do not allow float tab to contact needle while making adjustment as Viton needle tip may be damaged.

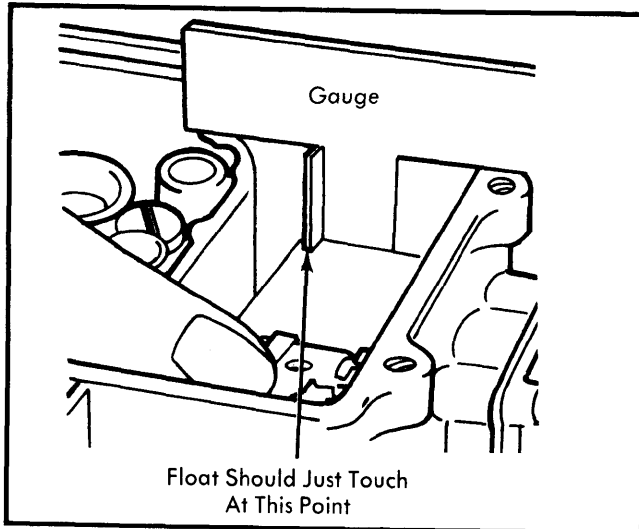

Fig. 2 Adjusting Float Level (Dry Setting)

FLOAT LEVEL (WET SETTING)

1) Warm up engine to operating temperature. Ensure vehicle is on flat, level surface. Stop engine and remove air cleaner and air horn attaching screws. Leave air horn in position on carburetor. Start engine. See Fig. 3.

2) Allow engine to idle for a few minutes to stabilize fuel level. With engine idling, remove air horn and gasket.

3) Measure distance, with suitable "T" scale, from machined surface of main body to level of fuel in fuel bowl. Make measurement at least $\frac{1}{4}$ " away from sides of bowl to be sure of accurate reading.

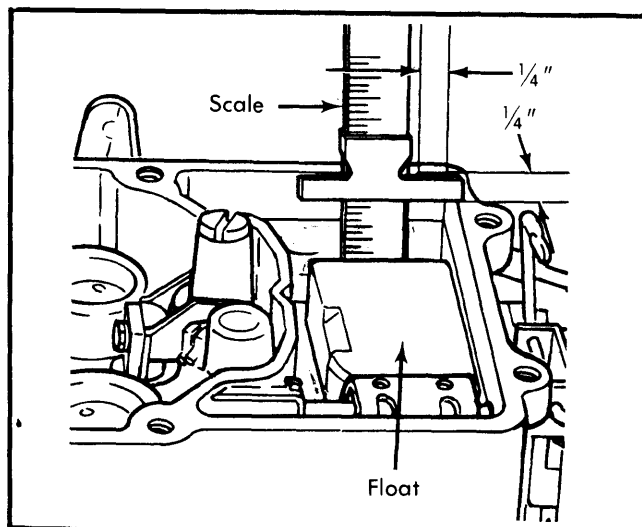

Fig. 3 Adjusting Float Level (Wet Setting)

4) If level is not within specifications, adjustment is needed. Stop engine before adjusting to avoid fire danger from fuel spray. Bend float tab (contacting inlet valve) up to raise fuel level and down to lower level.

5) After each adjustment, install air horn with 2 screws. Start engine and idle long enough for fuel level to stabilize to new setting. Stop engine and recheck fuel level.

6) When correct level is obtained, install new air horn gasket; replace air horn (install I.D. tag). Be sure plastic dust seal on choke rod is positioned properly and does not bind rod.

CHOKE VALVE PULL-DOWN

NOTE — Most applications have a tamper-proof choke, incorporating a sealed pull-down motor and break-away choke cap screws. Adjustments given are used when a major overhaul is performed or if components are damaged.

1) Loosen choke cover retainers. Open throttle and rotate choke cover until choke valve is held closed. Tighten choke cover.

2) Close throttle with fast idle speed adjustment screw on top step of fast idle cam.

3) Apply vacuum to hold choke diaphragm against set screw. Do not press on links.

NOTE — If vacuum is applied to choke diaphragm with a hand pump, an air leak may be detected. This is normal.

4) Measure clearance between lower edge of choke valve and air horn. If adjustment is required, turn screw at rear of diaphragm housing to achieve proper clearance. See Fig. 4.

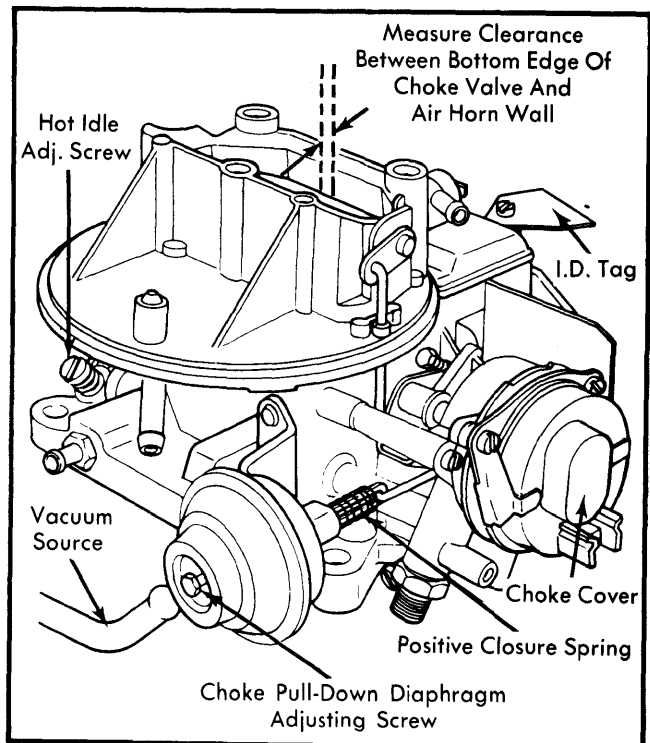

Fig. 4 Adjusting Choke Pull-Down Clearance

MOTORCRAFT MODEL 2150 2-BARREL (Cont.)

FAST IDLE CAM LINKAGE

NOTE — Adjust choke vacuum pull-down adjustment before adjusting fast idle cam linkage.

- 1) Perform steps 1) through 4) of Choke Pull-Down adjustment section.
- 2) Push down on fast idle cam lever until fast idle speed adjustment screw is in contact with second step and against shoulder of high step.
- 3) Measure clearance between upper edge of air horn wall and upper edge of choke valve. See Fig. 5.
- 4) If adjustment is required, turn fast idle cam lever screw to achieve correct adjustment. Reset automatic choke to proper adjustment notch.

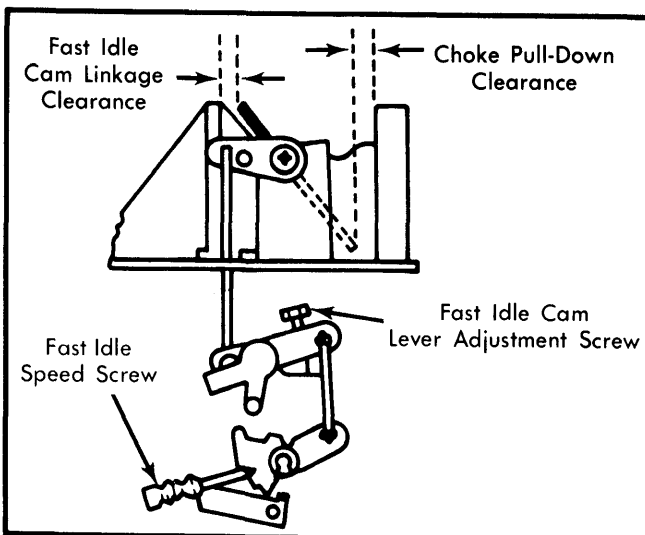

Fig. 5 Clearance Locations for Fast Idle Cam and Choke Valve Pull-Down Adjustment

CHOKE UNLOADER

- 1) Hold throttle fully open, and apply pressure on choke valve toward closed position. Measure specified choke unloader clearance between lower edge of choke valve and air horn wall.

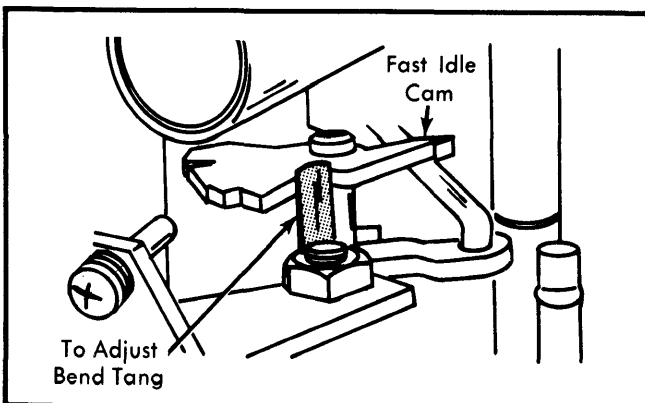

Fig. 6 Unloader Tang-to-Fast Idle Cam Clearance

- 2) To adjust, bend choke unloader tang that contacts fast idle cam. Bend tang toward cam to increase clearance and away from cam to decrease clearance. See Fig. 6.

- 3) After correct adjustment is obtained, open throttle until unloader tang is directly under fast idle cam pivot. Make sure there is .070" clearance between unloader tang and fast idle cam. See Fig. 7.

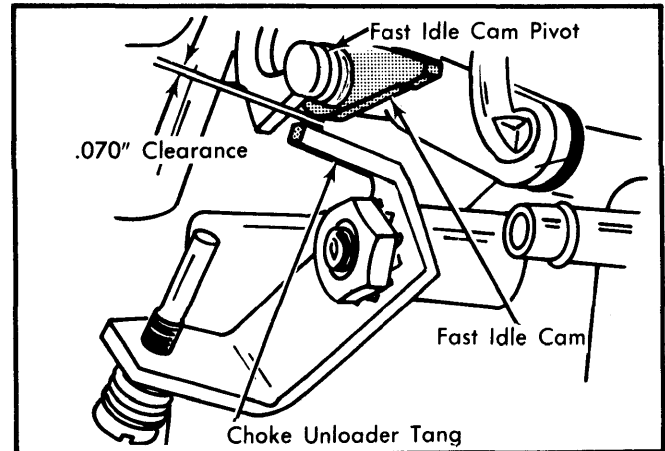

Fig. 7 Unloader Tang-to-Fast Idle Cam Clearance

- 4) Operate throttle and make sure that tang does not stick or bind against any portion of the linkage or carburetor casting.

AUTOMATIC CHOKE

- 1) Loosen choke thermostat cover retaining screws.
- 2) Rotate cover assembly in "Rich" or "Lean" direction to align reference mark on cover with specified scale graduation on housing. Tighten cover screws.

FUEL BOWL VENT

NOTE — This is not a precise adjustment. It is made only to ensure that vent is open at idle and that it closes as throttle opens. Adjustment can be made with carburetor on or off vehicle.

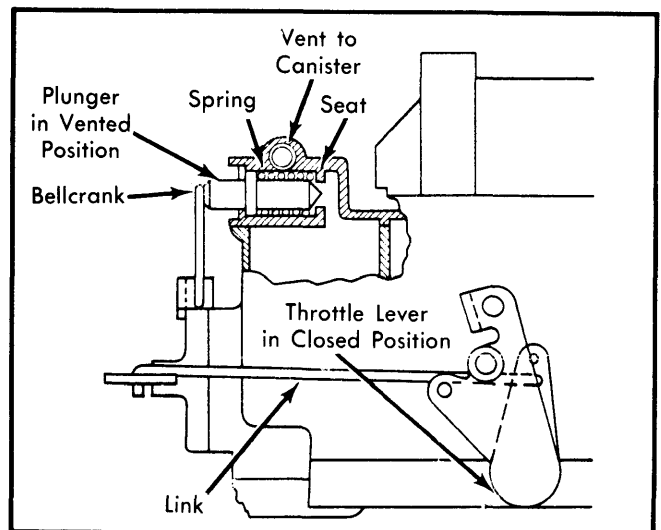

Fig. 8 Fuel Bowl Vent

MOTORCRAFT MODEL 2150 2-BARREL (Cont.)

1) If carburetor is installed on vehicle, make sure ignition is off. Make sure throttle is completely off fast idle cam.

2) Manually depress stem of bowl vent valve. Measure clearance between end of stem and flat on end of bell crank. See Fig. 8.

3) If clearance is not to specification, bend bell crank. Do not bend lever on accelerator pump.

OVERHAUL

DISASSEMBLY

Air Horn — 1) Remove air cleaner anchor screw and automatic choke control rod retainer. Remove air horn attaching screws, lockwashers, carburetor I.D. tag and air horn. Remove screw securing choke lever to choke shaft and remove choke rod and seal from air horn.

2) Remove choke diaphragm assembly, then if necessary to remove choke valve, file staking from retaining screws and remove screws. Remove choke valve by sliding it out from the top of the air horn. Remove choke shaft from air horn.

3) On models equipped with altitude compensator, the bypass choke plate is removed in same way as main choke plate. To remove shaft, remove link retainer and slide shaft out of air horn.

Automatic Choke — 1) Remove fast idle cam retainer, thermostatic choke coil housing screws and then remove clamp and gasket.

NOTE — Some models are equipped with rivets retaining choke coil cover to prevent tampering with factory adjustment. To remove rivets, align a .128" (No. 30) drill on rivet head and drill only enough to remove rivet head. Using an 1/8" punch, drive remaining portion of rivet from housing. Repeat for remaining rivets.

2) Remove choke housing screws, choke housing, gasket and fast idle cam rod from cam lever. Remove choke lever retaining screw and washer, then remove choke lever and fast idle cam lever.

Main Body — 1) Pry float shaft retainer from fuel inlet seat with a screwdriver, then remove float, float shaft retainer and fuel inlet needle assembly. Remove retainer and float shaft from float lever.

2) Remove fuel inlet needle seat, filter screen, and main jets. Remove booster venturi screw, booster venturi, metering rod assembly, and gasket. Remove filter screen from booster venturi screw.

3) Invert main body and catch accelerator pump discharge weight and check ball. Remove accelerator pump operating rod from overtravel lever and retainer by pressing ends of retainer together, while at the same time, pressing rod away from retainer until it is free.

NOTE — To disassemble metering rod assembly on 2150 models, remove lift spring retaining clip and spring. Do not remove metering rod hanger from lift rod.

4) Remove accelerator pump cover screws. Remove bowl vent bell crank and bracket, accelerator pump cover diaphragm and spring. If necessary to remove Elastomer valve, grasp firmly, from outside main body, and pull out.

NOTE — If tip of Elastomer valve broke off, make sure it is removed from fuel bowl. Elastomer valve must be replaced whenever it is removed.

5) Remove enrichment valve cover and gasket, then remove enrichment valve using a box wrench. Remove mixture needle limiter caps, mixture needles and springs. If necessary, remove nut and washer securing fast idle adjusting lever and remove lever. Remove throttle positioner solenoid (if equipped).

NOTE — To remove tamper-resistant plugs from idle adjustment screws, support the area under limiter plug and tap plug forward.

6) If necessary to remove throttle plates, mark each throttle plate with its corresponding bore for reassembly. Slide throttle shaft from main body. Mechanical high speed bleed actuator will drop out. It is located between throttle plates in main body. On altitude compensated carburetors, remove 4 attaching screws and remove aneroid and valve assembly.

CLEANING & INSPECTION

- Use a regular carburetor cleaning solution. Soak components long enough to thoroughly clean all surfaces and passages of foreign matter.
- Do not soak any components containing rubber, leather or plastic.
- Remove any residue after cleaning by rinsing components in a suitable solvent.
- Blow out all passages with dry compressed air.

REASSEMBLY

NOTE — Use new gaskets and seals. Make sure that new gaskets fit correctly and that all holes and slots are punched through and correctly located. Replace Elastomer valve if removed from main body.

To reassemble carburetor, reverse disassembly procedure and note the following:

1) When installing Elastomer check valve (if removed), lubricate tip of new valve and insert tip into center hole of accelerator pump cavity. Use needle nose pliers inserted in fuel bowl and pull valve in until it is fully seated. Cut off excess valve tip at retaining shoulder and remove tip from fuel bowl.

2) When installing idle mixture needles and springs, turn screws in with fingers until lightly seated. Then back screws off seated position 1 1/2 turns for an initial adjustment. Do not install idle screw limiter caps until final adjustments have made.

3) If choke coil cover was removed, reinstall using 3 beads of epoxy sealant to each side of choke gasket adjacent to choke cap screw bosses. Position gasket, choke cap, and retainer, and mount using break-away screws.

1981 Motorcraft Carburetors

MOTORCRAFT MODEL 2150 2-BARREL (Cont.)

CARBURETOR ADJUSTMENT SPECIFICATIONS								
Application	Float Level		Accel. Pump Setting	Choke Pull-Down Setting	Fast Idle Cam Setting	Choke Unloader Setting	Auto. Choke Setting	Bowl Vent Valve Setting ^①
	Dry Setting	Wet Setting						
Ford								
E1UE-GA	7/16"	.81"	No. 2	.13"	V Notch	.20"	V Notch	3/8"
E1UE-KA	31/64"	.86"	No. 3	.18"	V Notch	.25"	V Notch	3/64"
E1TE-BFA	31/64"	.88"	No. 2	.14"	V Notch	.20"	V Notch	3/8"
E1TE-BGA	31/64"	.86"	No. 3	.15"	V Notch	.25"	V Notch
E1TE-BHA	31/64"	.86"	No. 2	.14"	V Notch	.20"	V Notch	3/8"
E1TE-BJA	31/64"	.88"	No. 3	.15"	V Notch	.25"	V Notch	3/8"
E1TE-BVA & E1TE-CSA	7/16"	.81"	No. 2	.13"	V Notch	.20"	V Notch	3/8" ^②
E1TE-BYA	31/64"	.88"	No. 4	.18"	V Notch	.25"	V Notch
E1TE-BZA	31/64"	.88"	No. 4	.18"	V Notch	.25"	V Notch	3/8"
E1TE-CAA	31/64"	.86"	No. 4	.18"	V Notch	.25"	V Notch	3/8"
E1TE-CBA	31/64"	.88"	No. 4	.18"	V Notch	.25"	V Notch
E1TE-CCA	31/64"	.88"	No. 4	.16"	V Notch	.25"	V Notch
E1TE-CDA	31/64"	.88"	No. 4	.16"	V Notch	.25"	V Notch
E1TE-CEA	31/64"	.86"	No. 4	.16"	V Notch	.20"	V Notch
E1TE-CFA	31/64"	.86"	No. 4	.16"	V Notch	.20"	V Notch
E1TE-CHA	31/64"	.88"	No. 3	.15"	V Notch	.25"	V Notch	3/8"
E1TE-CKA	7/16"	.81"	No. 2	.13"	V Notch	.20"	V Notch	3/8"
E1TE-CLA	7/16"	.81"	No. 2	.13"	V Notch	.20"	V Notch
E1TE-CMA	7/16"	.81"	No. 2	.13"	V Notch	.20"	V Notch	3/8"
E1TE-CNA	7/16"	.81"	No. 2	.13"	V Notch	.20"	V Notch	3/8"
E1TE-CPA	7/16"	.81"	No. 2	.13"	V Notch	.20"	V Notch	3/8"
E1TE-CRA	7/16"	.81"	No. 2	.13"	V Notch	.20"	V Notch	3/8"
Jeep								
DMJ2	.38"	.93"	No. 3	.13"	.12"	.30"	2NR	.12"
DA2J	.38"	.93"	No. 3	.13"	.12"	.30"	1NR	.12"
DM2A	.38"	.93"	No. 3	.13"	.12"	.36"	1NR	.12"
RHM2	.38"	.93"	No. 3	.10"	.08"	.35"	2NR	.12"
RHA2	.38"	.93"	No. 3	.11"	.09"	.35"	2NR	.12"

① - Specification is size of fuel bowl vent tube except E1UE-KA, which is bowl vent valve setting.

② - Not applicable to E1TE-CSA.