

## GENERAL MOTORS VACUUM DIAGRAMS

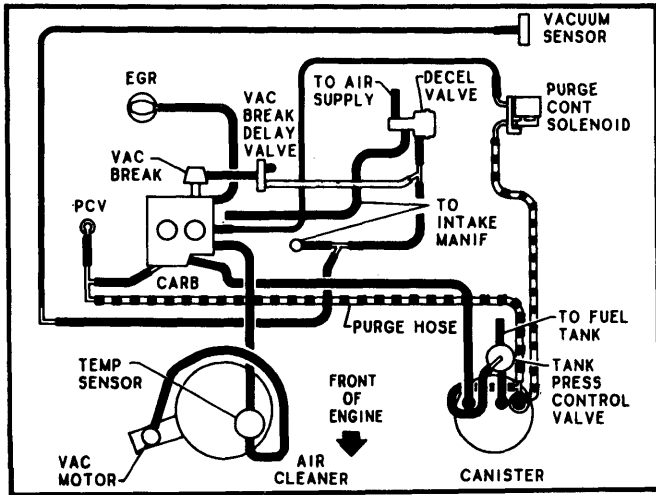
### GENERAL MOTORS VACUUM DIAGRAMS INDEX

Engine	Notes	Fig. No.
1.6L (98") 4-Cyl. ....	All Models .....	1
1.8L (111") 4-Cyl. Diesel .....	Chevette .....	2
1.8L (113") 4-Cyl. ....	"J" Cars .....	3
2.5L (151") 4-Cyl. ....	All Models .....	4
2.8L (173") V6 .....	Federal Man. Trans. ....	5
2.8L (173") V6 .....	Federal. Auto. Trans. ....	6
2.8L (173") V6 .....	Calif. Auto. Trans. ....	7
3.8L (229") V6 .....	All Models .....	8
3.8L (231") V6 .....	Federal Man. Trans. ....	9
3.8L (231") V6 .....	Federal Auto. Trans. ....	10
3.8L (231") V6 .....	Federal Auto. Trans. ....	11
3.8L (231") V6 .....	Federal Auto. Trans. ....	12
3.8L (231") V6 .....	Calif. Auto. Trans. ....	13
3.8L (231") V6 .....	Calif. Auto. Trans. ....	14
3.8L (231") V6 Turbo .....	Federal Auto. Trans. ....	15
3.8L (231") V6 Turbo .....	Calif. Auto. Trans. ....	16
4.1L (252") V6 .....	Federal Auto. Trans. ....	17
4.1L (252") V6 .....	Calif. Auto. Trans. ....	18
4.3L (260") V8 .....	All Models .....	19
4.3L (265") V8 .....	All Models .....	20
4.4L (267") V8 .....	All Models .....	①
4.9L (301") V8 .....	All Models .....	21
4.9L (301") V8 Turbo .....	All Models .....	22
5.0L (305") V8 .....	All Models .....	①
5.0L (307") V8 .....	All Models .....	23
5.7L (350") V8 .....	Federal .....	24
5.7L (350") V8 .....	Calif. ....	25
5.7L (350") V8 Diesel .....	Federal Rear Wheel Drive .....	26
5.7L (350") V8 Diesel .....	Federal Front Wheel Drive .....	27
5.7L (350") V8 Diesel .....	Calif. Rear Wheel Drive (Exc. Wagon) .....	28
5.7L (350") V8 Diesel .....	Calif. Rear Wheel Drive (Wagon) .....	29
5.7L (350") V8 Diesel .....	Calif. Front Wheel Drive .....	30
6.0L (368") V8 .....	Rear Wheel Drive .....	31
6.0L (368") V8 .....	Front Wheel Drive .....	32

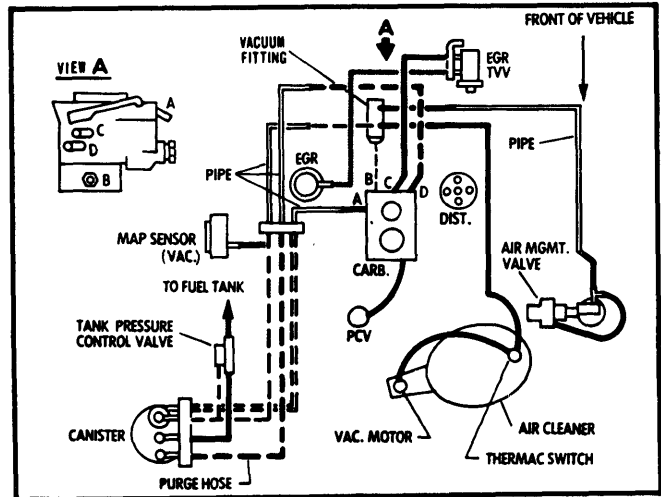
① - Vacuum diagrams not available from manufacturer at time of publication.

# 1981 Exhaust Emission Systems

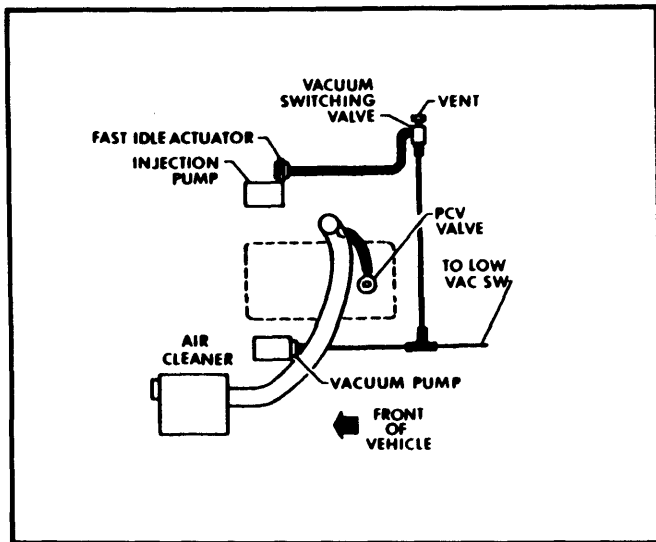
## GENERAL MOTORS VACUUM DIAGRAMS (Cont.)



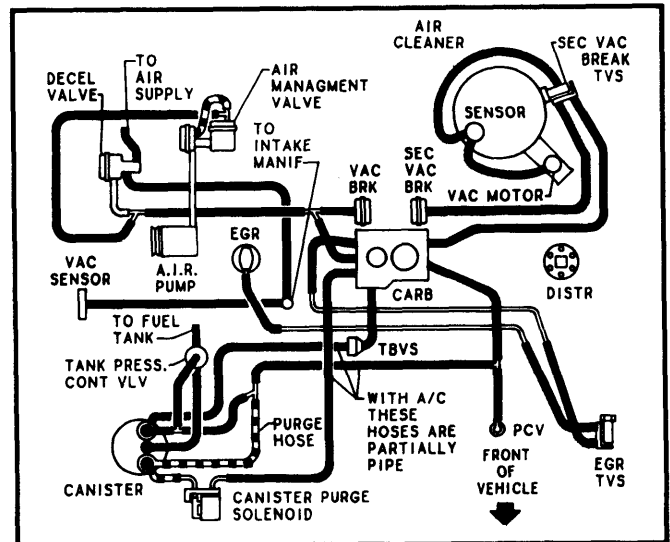
**Fig. 1 1.6L (98") 4-Cyl. All Models**



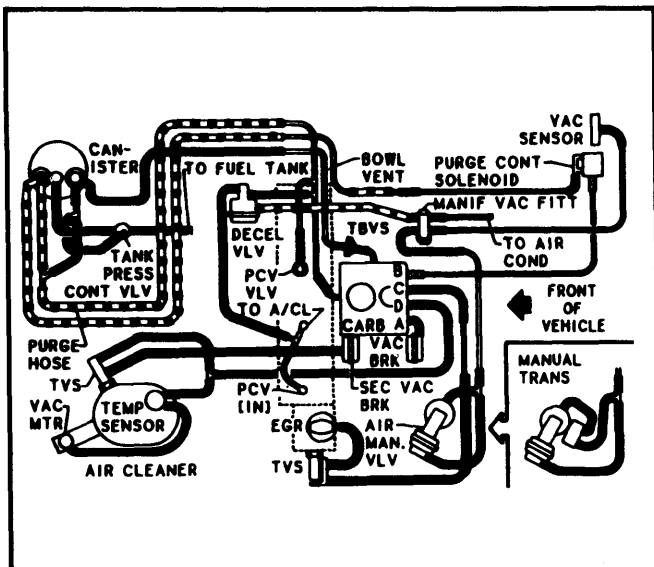
**Fig. 4 2.5L (151") 4-Cyl. All Models**



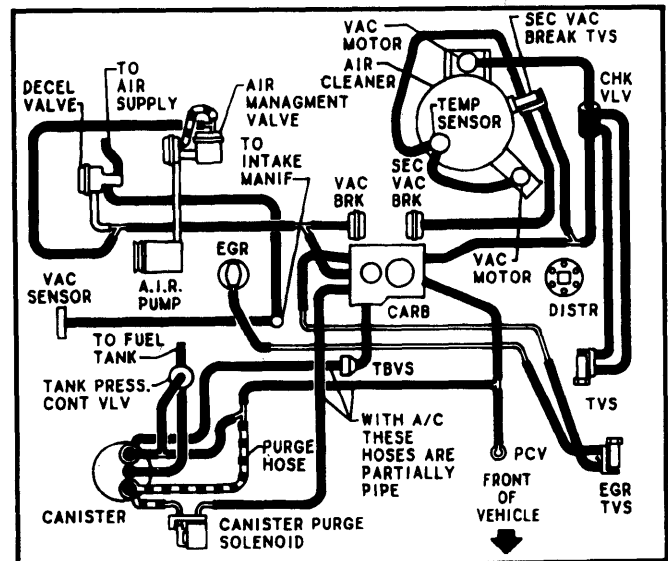
**Fig. 2 1.8L (111") 4-Cyl. Diesel All Models**



**Fig. 5 2.8L (173") V6 Federal Man. Trans.**

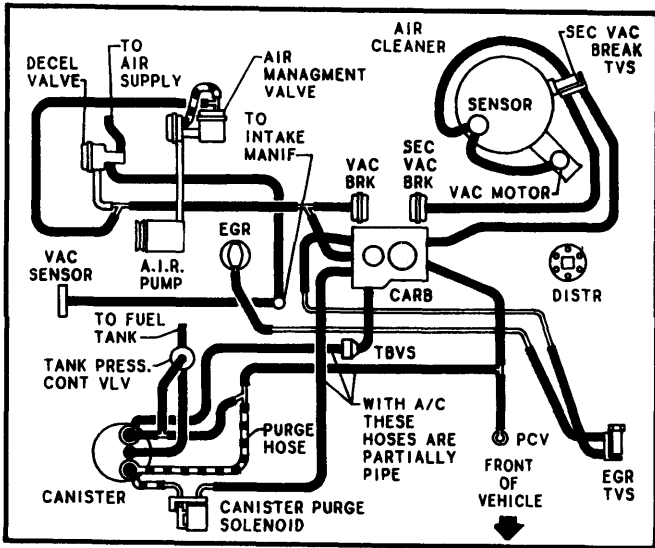


**Fig. 3 1.8L (113") 4-Cyl. Gasoline All Models**

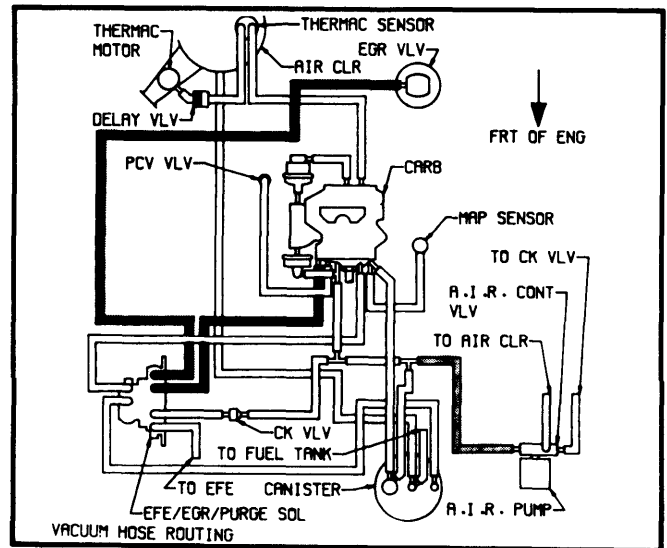


**Fig. 6 2.8L (173") V6 Federal Auto. Trans.**

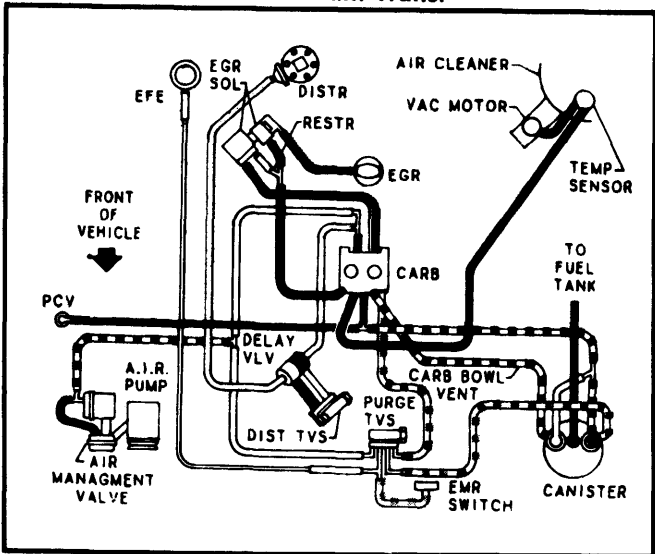
## GENERAL MOTORS VACUUM DIAGRAMS (Cont.)



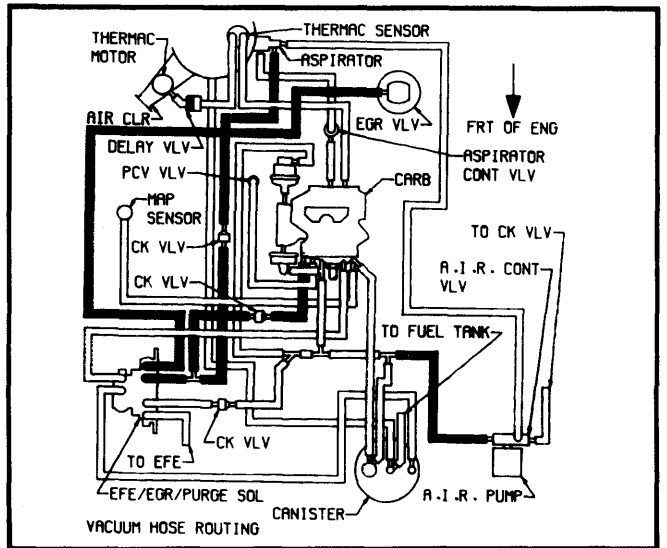
**Fig. 7 2.8L (173") V6  
Calif. Man. Trans.**



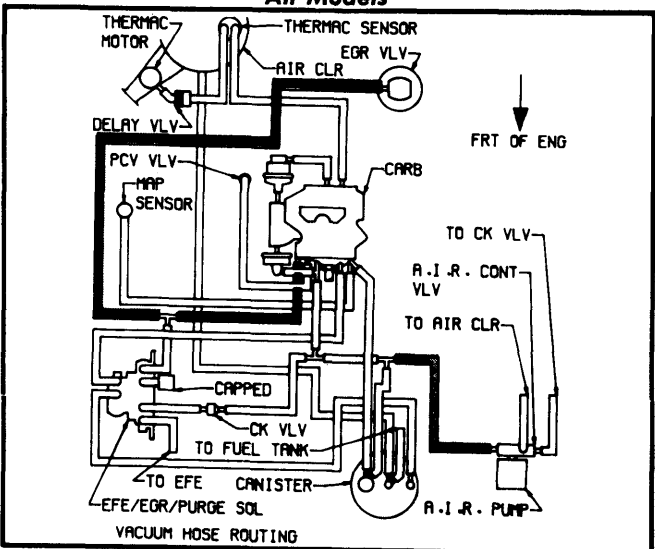
**Fig. 10 3.8L (231") V6  
Federal Auto. Trans.**



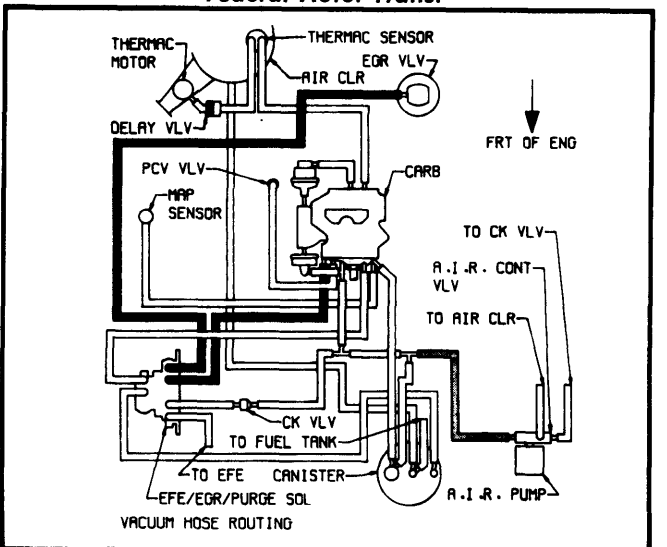
**Fig. 8 3.8L (229") V6  
All Models**



**Fig. 11 3.8L (231") V6  
Federal Auto. Trans.**



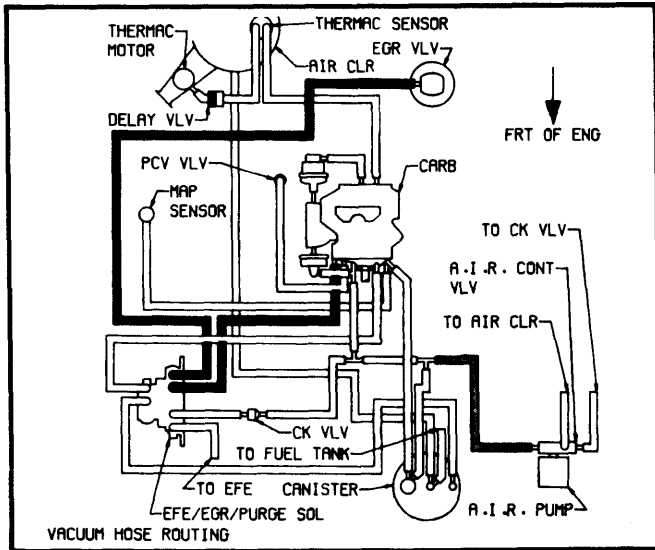
**Fig. 9 3.8L (231") V6  
Federal Man. Trans.**



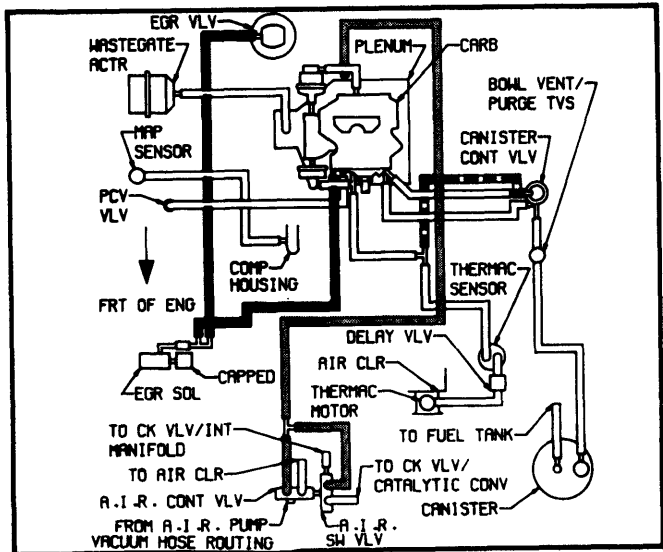
**Fig. 12 3.8L (231") V6  
Federal Auto. Trans.**

# 1981 Exhaust Emission Systems

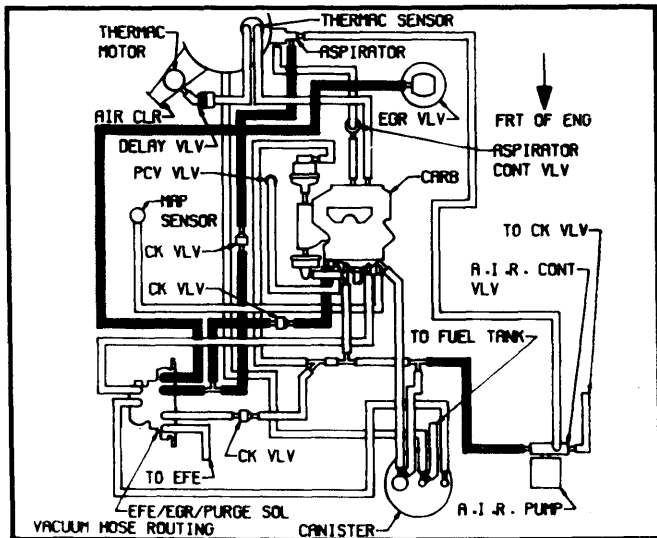
## GENERAL MOTORS VACUUM DIAGRAMS (Cont.)



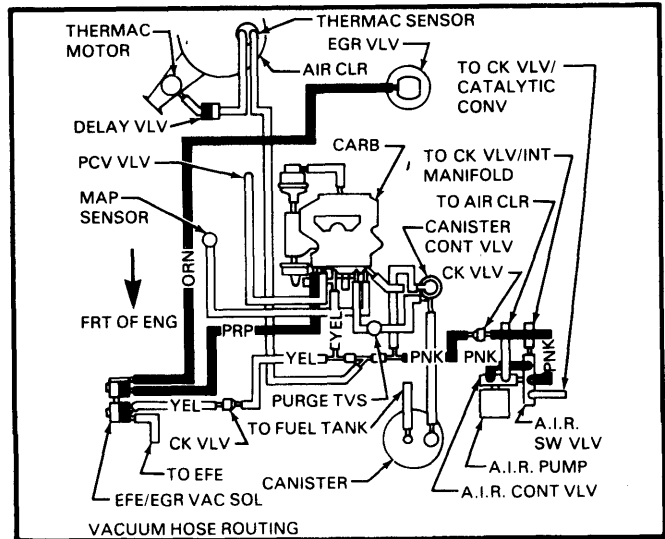
**Fig. 13 3.8L (231") V6  
Calif. Auto. Trans.**



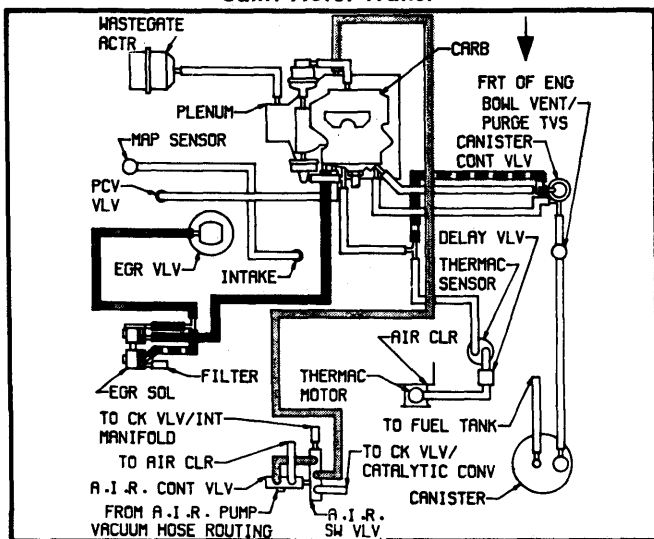
**Fig. 16 3.8L (231") Turbo V6  
Calif. Auto. Trans.**



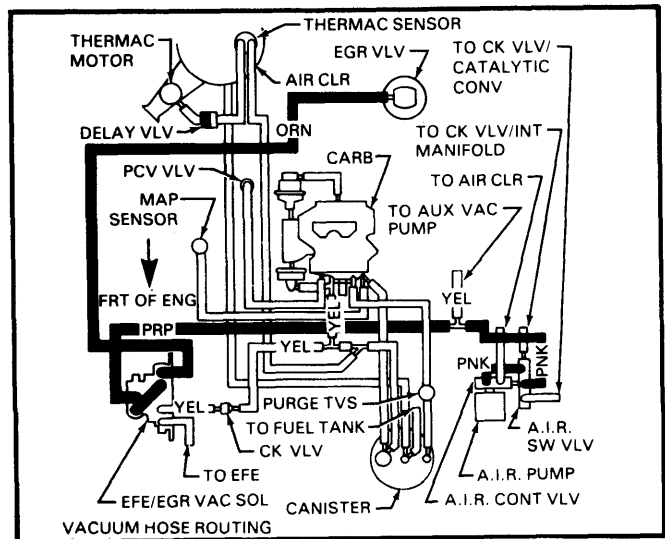
**Fig. 14 3.8L (231") V6  
Calif. Auto. Trans.**



**Fig. 17 4.1L (252") V6  
Federal Auto. Trans.**

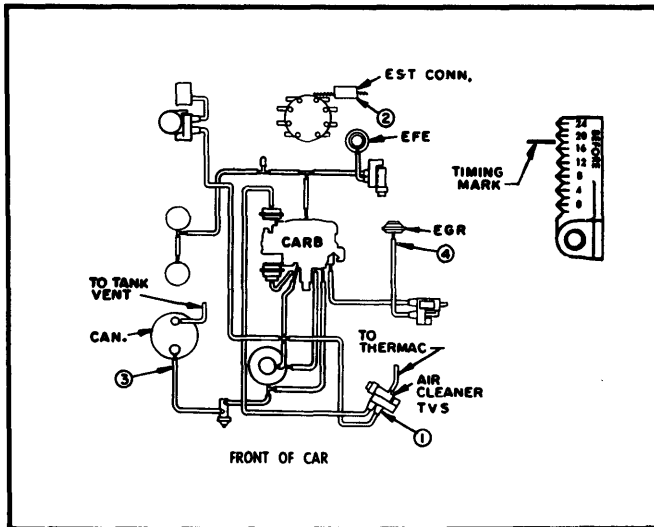


**Fig. 15 3.8L (231") Turbo V6  
Federal Auto. Trans.**

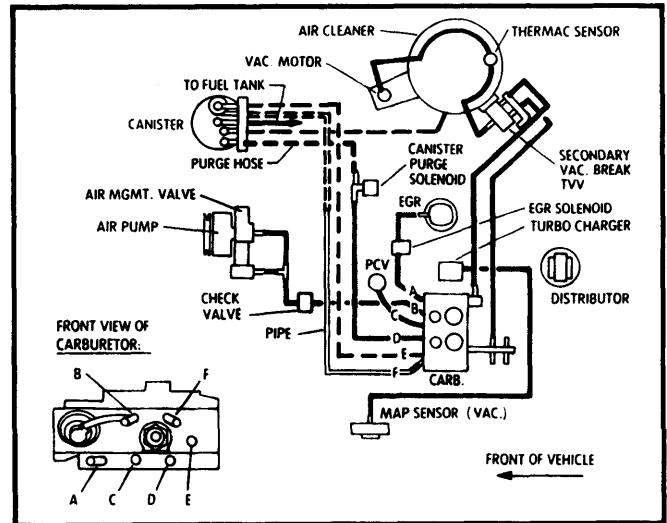


**Fig. 18 4.1L (252") V6  
Calif. Auto. Trans.**

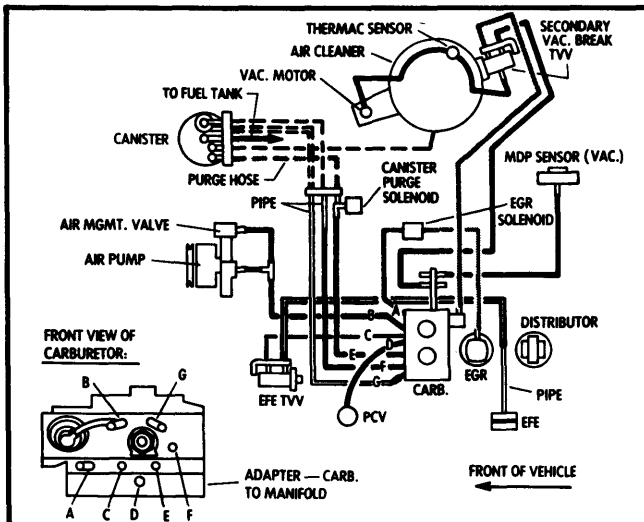
## GENERAL MOTORS VACUUM DIAGRAMS (Cont.)



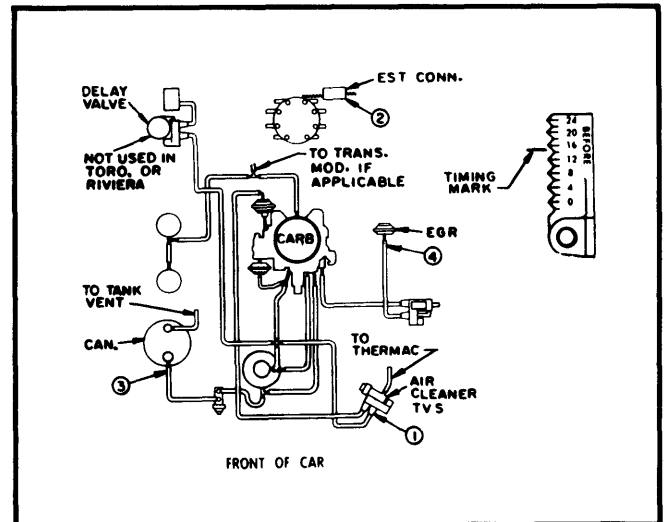
**Fig. 19 4.3L (260") V8  
All Models**



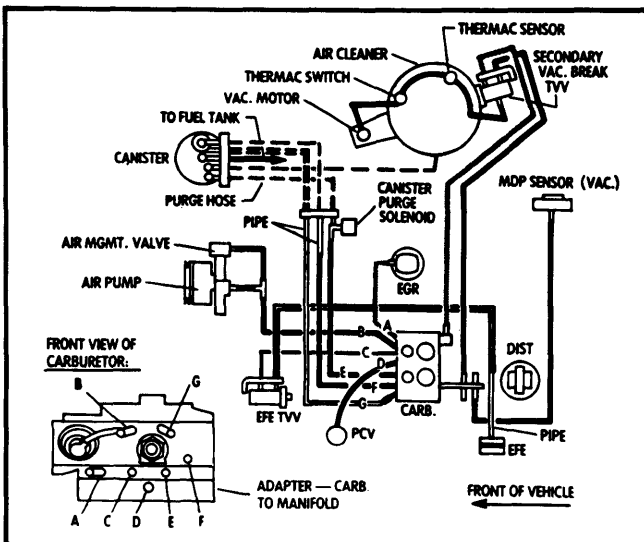
**Fig. 22 4.9L (301") Turbo V8  
All Models**



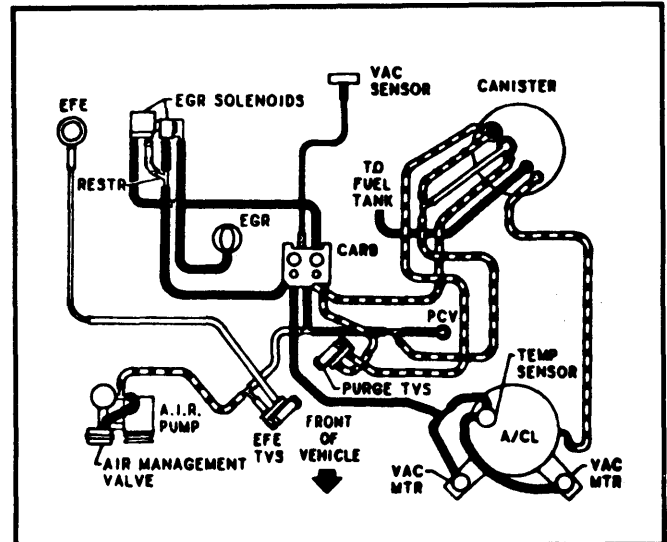
**Fig. 20 4.3L (265") V8  
All Models**



**Fig. 23 5.0L (307") V8  
All Models**



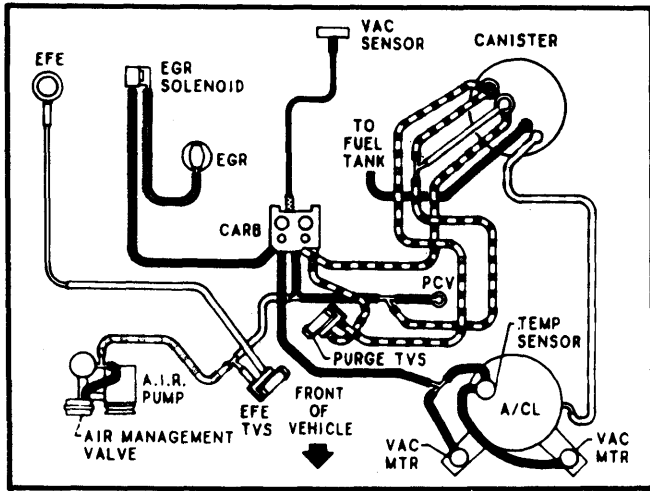
**Fig. 21 4.9L (301") V8  
All Models**



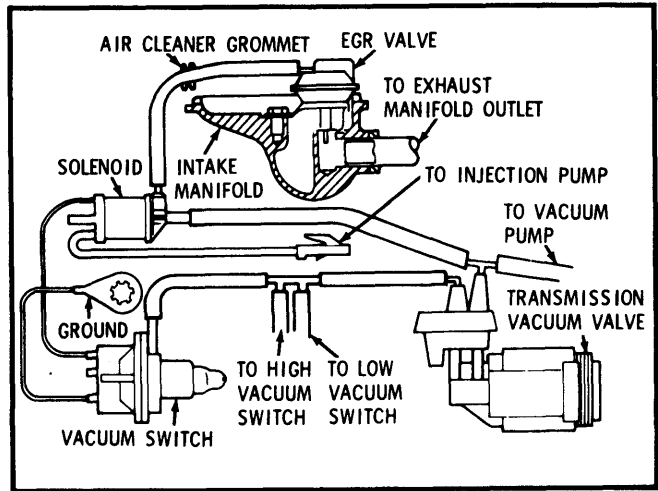
**Fig. 24 5.7L (350") V8  
Federal**

# 1981 Exhaust Emission Systems

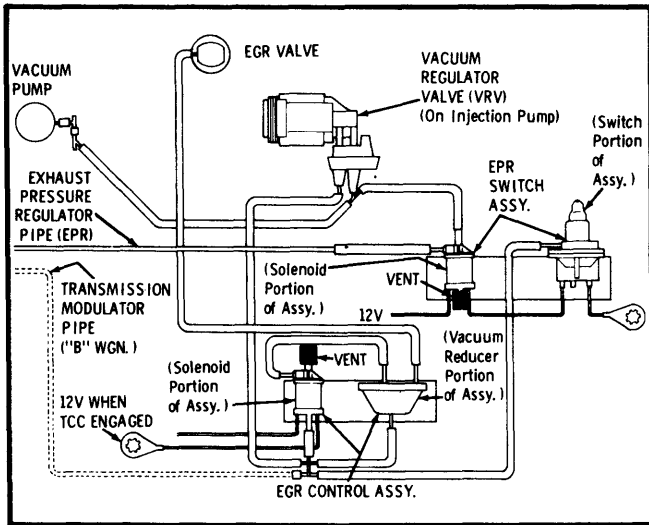
## GENERAL MOTORS VACUUM DIAGRAMS (Cont.)



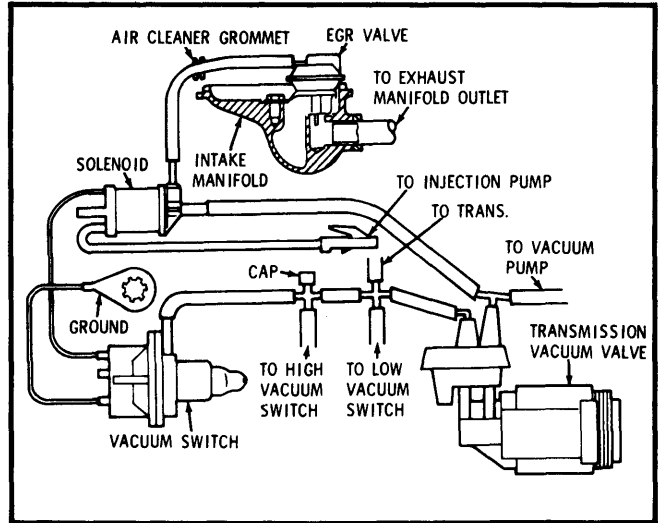
**Fig. 25 5.7L (350") V8 Calif.**



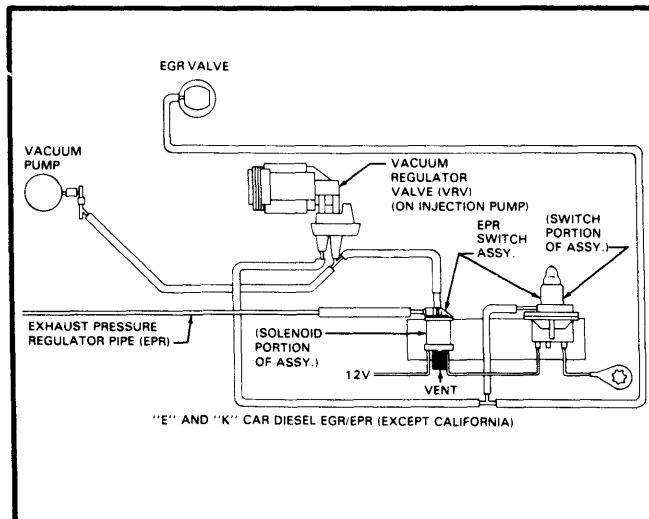
**Fig. 28 5.7L (350") Diesel V8 Calif. Rear Wheel Drive (Exc. Wagon)**



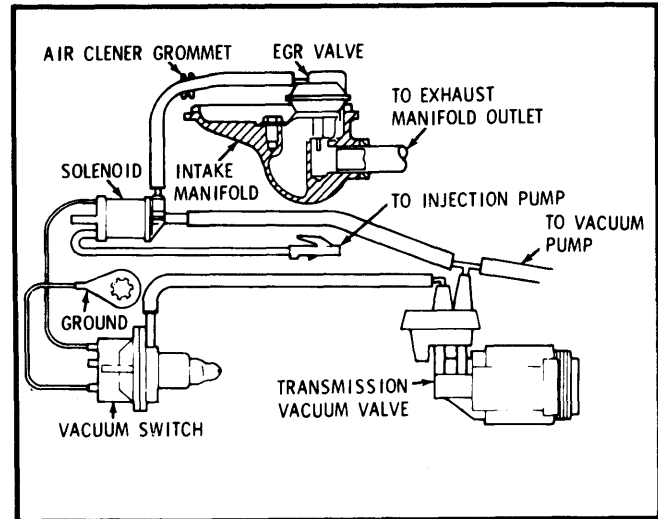
**Fig. 26 5.7L (350") Diesel V8 Federal Rear Wheel Drive**



**Fig. 29 5.7L (350") Diesel V8 Calif. Rear Wheel Drive (Wagon)**

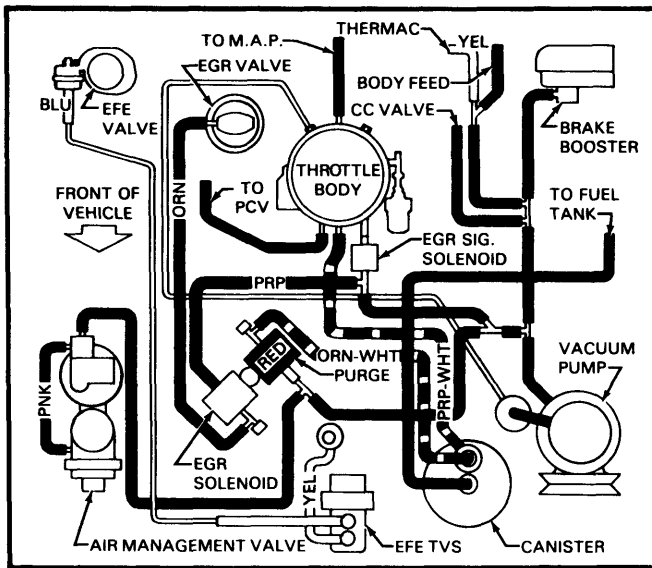


**Fig. 27 5.7L (350") Diesel V8 Federal Front Wheel Drive**

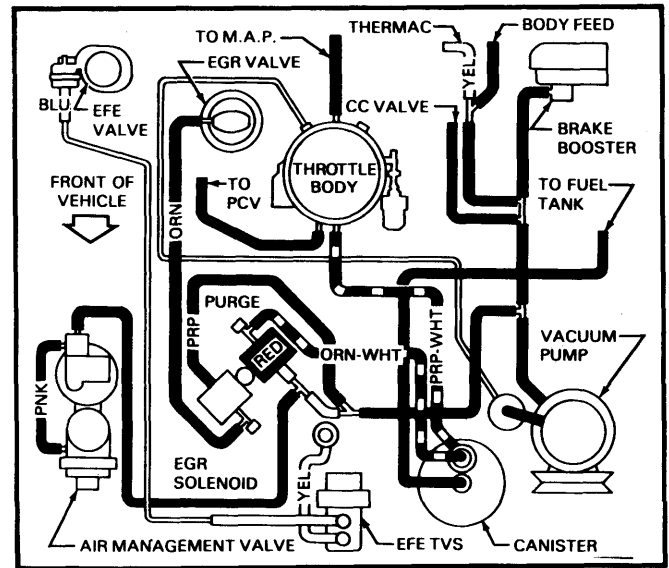


**Fig. 30 5.7L (350") Diesel V8 Calif. Front Wheel Drive**

## GENERAL MOTORS VACUUM DIAGRAMS (Cont.)



**Fig. 31 6.0L (368") V8-6-4  
All Rear Wheel Drive Models**



**Fig. 32 6.0L (368") V8-6-4  
All Front Wheel Drive Models**