

GENERAL MOTORS DIGITAL FUEL INJECTION

Cadillac

DESCRIPTION

The General Motors digital fuel injection system (DFI) consists of 11 major sub-assemblies: Fuel delivery, air induction, data sensors, Electronic Control Module (ECM), Electronic Spark Timing (EST), Idle Speed Control (ISC), emission controls, closed loop fuel control, system diagnostics, cruise control, catalytic converter and Modulated Displacement (MD).

Fuel is supplied to engine through 2 electronically pulsed (timed) injector valves located in throttle body on top of intake manifold. The ECM controls amount of fuel metered through injector valves based upon engine demand and efficiency information. The ECM is a digital electronic computer which receives and computes signals from various sensors.

NOTE — Primary sub-systems which affect fuel system operation will be covered in this section: Fuel delivery, air induction, Idle Speed Control (ISC), data sensors, Electronic Control Module (ECM), and closed loop fuel control. Refer to "GENERAL MOTORS DFI CONTROL SYSTEM" in Computerized Engine Controls section for more information.

OPERATION

FUEL DELIVERY

An electric fuel pump (located inside fuel tank as an integral part of fuel gauge sending unit) supplies fuel under pressure to throttle body. The ECM actuates fuel pump through fuel pump relay located in relay panel when ignition is turned on or to start position. If engine stalls or is not cranked within 1 second after ignition is turned on, ECM will deactivate fuel pump.

The fuel pressure regulator is an integral part of throttle body. A diaphragm-operated relief valve regulates fuel pressure. Relief valve is exposed to atmospheric pressure on bottom side and top side senses fuel pressure to maintain constant 10.5 psi pressure across fuel injectors. Fuel in excess of that used to maintain pressure is returned to fuel tank through fuel return line.

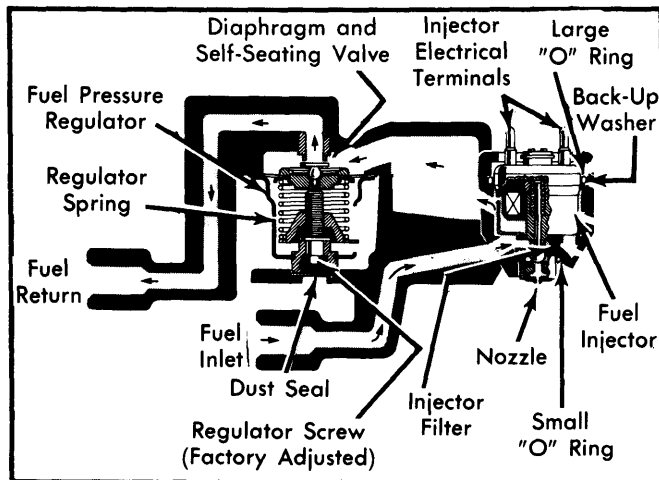

Fig. 1 Sectional View of Fuel Pressure Regulator

During normal running, 2 fuel injectors are actuated alternately by the ECM and they direct metered atomized fuel into the throttle bores above the throttle valves. Both injectors are actuated simultaneously during cranking.

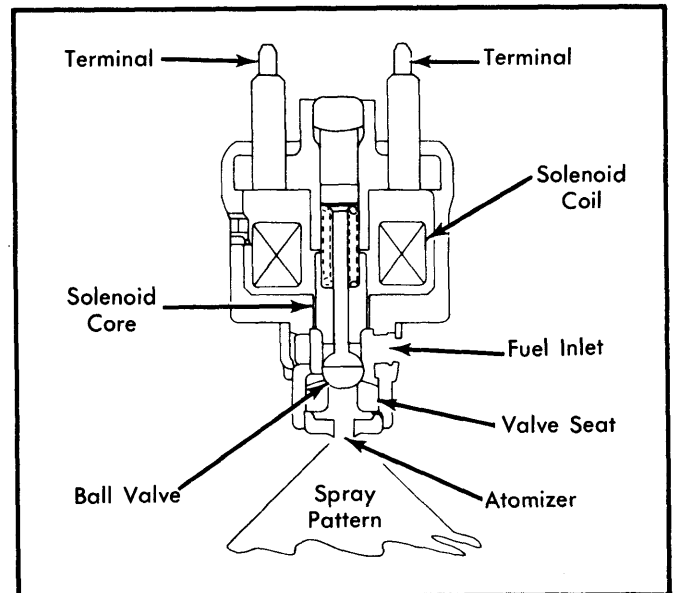

Fig. 2 Sectional View of Injector Valve

AIR INDUCTION

The air induction system consists of throttle body and intake manifold. Air for combustion enters throttle body and is distributed to each cylinder through intake manifold. Throttle body contains special distribution skirt below each injector valve to improve fuel distribution. Air flow rate is controlled by throttle valves which are connected to accelerator linkage. Idle speed is determined by position of throttle valves and is controlled by ISC.

DATA SENSORS

Each sensor furnishes an electronic signal to ECM, modifying injector pulse to conform to operating conditions of the engine. These sensors are as follows:

Manifold Air Temperature (MAT) — This sensor is mounted in the intake manifold directly in front of the throttle body. The MAT sensor measures air/fuel mixture temperature in the intake manifold. The sensor resistance changes as air temperature changes. ECM receives this change in signal and adjusts injector pulse accordingly. Low temperature produces high resistance.

Coolant Temperature Sensor (CTS) — The CTS is located in right front corner of engine directly below thermostat. This sensor provides information to ECM for fuel enrichment, ignition timing, EGR operation, canister purge control, air management, early fuel evaporation control, closed loop fuel control and modulated displacement.

Manifold Absolute Pressure (MAP) — The MAP sensor is mounted under the instrument panel near the right side A/C outlet. A hose from the throttle body to the MAP provides a vacuum signal. The sensor monitors changes in intake manifold pressure which result from engine load, speed and barometric pressure variations. As intake manifold pressure increases, additional fuel is required. MAP sends this information to ECM so that the pulse width is increased (time injector is open). As manifold pressure decreases, pulse width is shortened.

GENERAL MOTORS DIGITAL FUEL INJECTION (Cont.)

Barometric Pressure Sensor (BARO) — The BARO sensor is mounted on the MAP sensor bracket. This unit senses ambient or barometric pressures and signals the ECM on pressure changes due to altitude and weather.

Throttle Position Sensor (TPS) — The throttle position sensor is mounted on side of throttle body and connected directly to throttle shaft. This unit senses throttle movement and position and transmits appropriate electrical signals to ECM. The ECM processes these signals to determine conditions for the ISC system and to supply fuel enrichment.

Vehicle Speed Sensor — Vehicle speed sensor informs ECM of vehicle speed. Speed sensor produces a weak signal which is amplified by a buffer amplifier. Speed sensor and buffer amplifier are mounted behind speedometer cluster. The ECM uses vehicle speed sensor signals for logic required to operate MPG sentinel, integral cruise control, modulated displacement and idle speed control system.

Engine Speed Sensor — The engine speed signal comes from speed sensor module in EST distributor. Pulses from distributor are sent to ECM where time between pulses is used to calculate engine speed and spark advance.

Oxygen Sensor — Oxygen sensor used in DFI system is a closed end Zirconia sensor placed in exhaust gas stream. This sensor generates a very weak voltage which varies with oxygen content of exhaust gases. As oxygen content of exhaust gases increases, a leaner mixture is indicated by low voltage output. As oxygen content decreases, a richer mixture is indicated by higher voltage output. The ECM corrects air/fuel ratio according to signals received from oxygen sensor.

CAUTION — No attempt should be made to measure oxygen sensor voltage output. Current drain of conventional voltmeter could permanently damage sensor, shift sensor calibration range and/or render sensor unusable. Do not connect jumper wire, test leads or other electrical connectors to sensor.

ELECTRONIC CONTROL MODULE

The ECM is mounted under the right end of instrument panel and consists of various printed circuit boards mounted in a metal box. All sensor inputs are fed into ECM and are processed to produce proper pulse duration for injectors, correct idle speed and proper spark advance. All sensors send analog inputs, which are converted to digital inputs before processing.

IDLE SPEED CONTROL (ISC)

The ISC is an electrically driven actuator which changes throttle valve angle, in idle position, according to commands from the ECM. This function is by-passed when throttle is opened enough to bring the TPS off its idle circuit. The ISC is located on side of throttle body.

CLOSED LOOP FUEL CONTROL

Closed loop fuel control maintains an air/fuel ratio of 14.7:1. Oxygen sensor monitors oxygen content of exhaust gases, sends information to ECM and ECM corrects air/fuel mixture for deviations from ideal ratio.

TROUBLESHOOTING & DIAGNOSIS

NOTE — Diagnosis of fuel system should begin with determining correct fuel pump operation. Connect fuel pressure gauge (J-25400-300) to fuel line servicing fitting and measure fuel pressure while cranking engine. Use Fuel System Diagnosis chart if pressure is not between 9-12 psi. Use Injector System Diagnosis chart if pressure is between 9-12 psi.

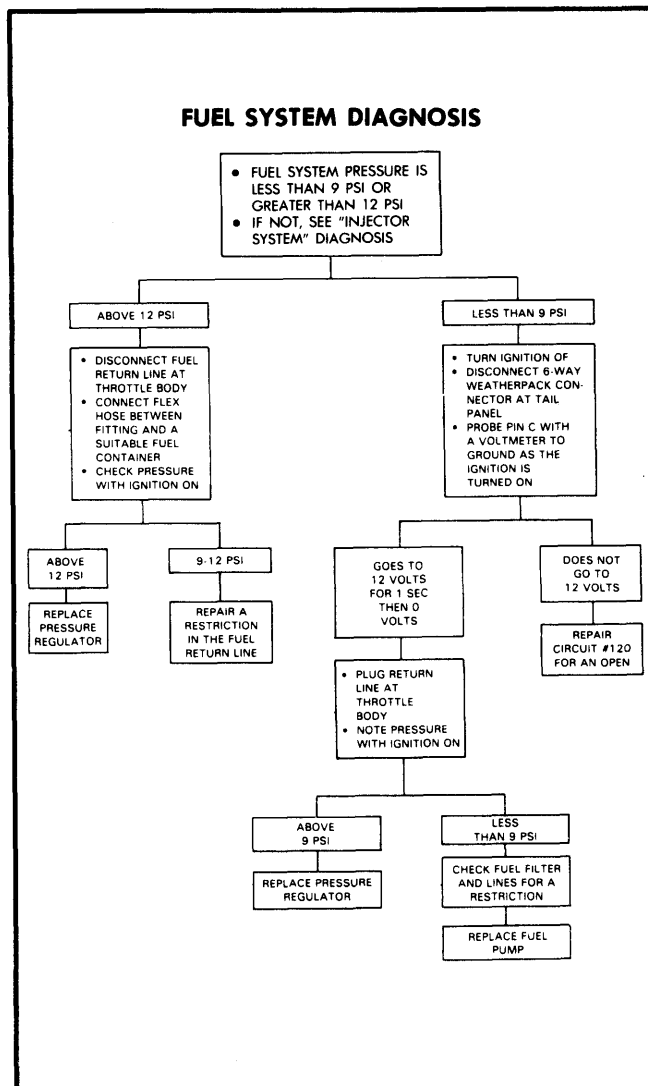

FLOODING, ROUGH IDLE

1) After using appropriate diagnostic chart, remove injector(s). Inspect large and small "O" rings for cuts, distortion or other damage. Check that steel back-up washer is located beneath large (upper) "O" ring. Use new "O" rings during re-installation.

2) Inspect fuel injector fuel filters for cleanliness and damage. Clean or replace as necessary. DO NOT immerse injectors, filters or rubber parts in carburetor cleaner.

NOTE — If diagnostic chart indicated fuel injector(s) continue to spray fuel with electrical connection removed, replace injector(s) as required.

1981 Fuel Injection

GENERAL MOTORS DIGITAL FUEL INJECTION (Cont.)

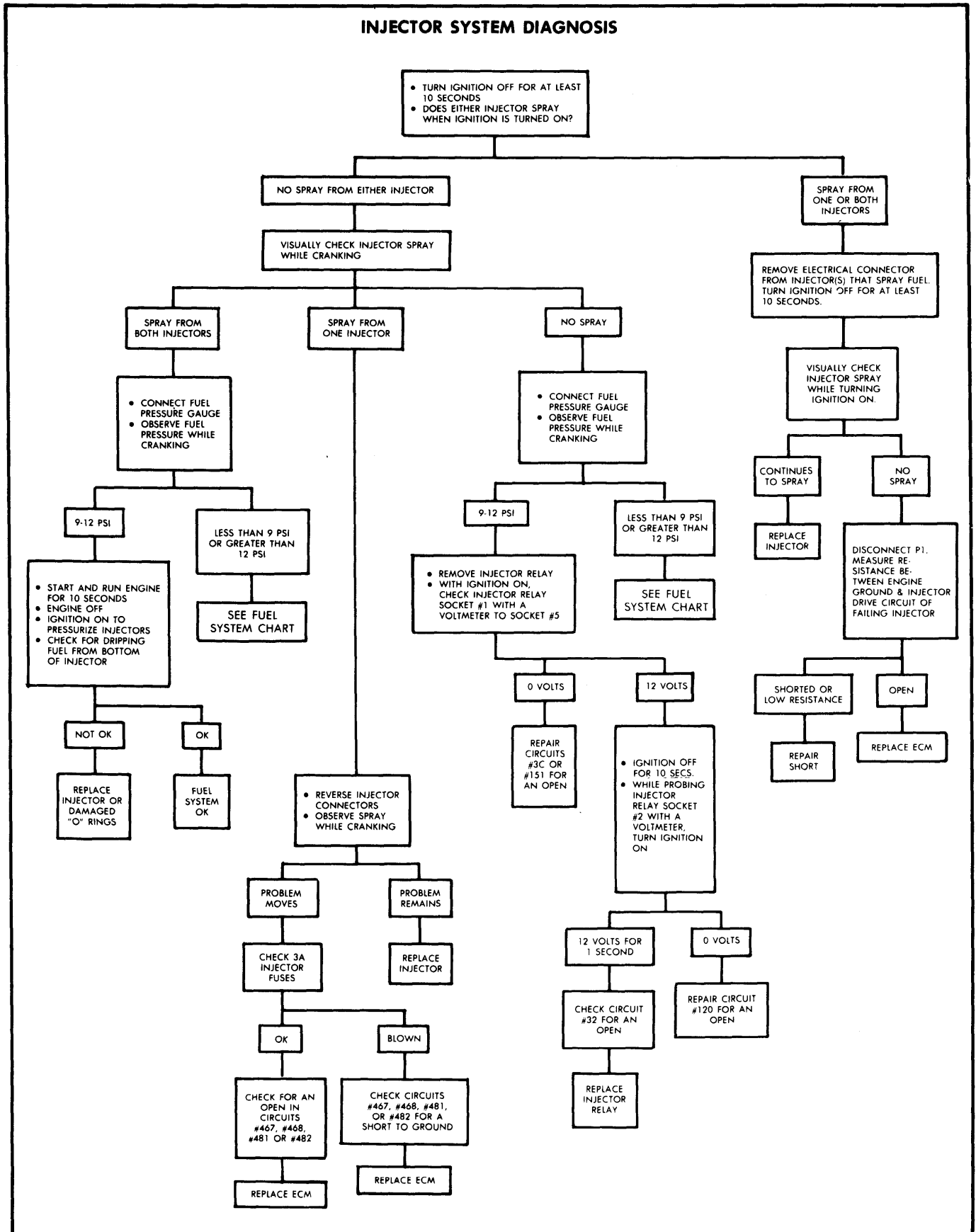

GENERAL MOTORS DIGITAL FUEL INJECTION (Cont.)

**HARD STARTING, HESITATION
POOR COLD OPERATION**

Follow appropriate diagnostic chart, then remove injectors and inspect for dirt or plugging. Clean and replace as necessary. Check for restricted inlet and outlet passages or inoperative pressure regulator. Repair or replace defective parts.

NOTE — DO NOT remove 4 fuel pressure regulator screws from fuel metering cover. Fuel pressure regulator and cover are serviced as an assembly only. Do not soak pressure regulator, fuel meter cover, injectors, filters, diaphragms or rubber components in carburetor cleaner.

REMOVAL & INSTALLATION**ELECTRONIC CONTROL MODULE (ECM)**

Removal — Disconnect battery negative cable. Remove lower instrument panel cover. Remove 3 nuts securing ECM and 1 nut securing ground strap. Disconnect harness connectors and remove ECM.

Installation — Position ECM under right end of instrument panel and attach harness connectors. Place ECM onto its bracket and install ground strap and retaining nuts. Install lower instrument panel and connect negative battery cable.

THROTTLE BODY ASSEMBLY

Removal — 1) Remove air cleaner. Disconnect and clear ISC actuator, IPS and injector electrical connections. Remove throttle return springs, cruise control linkage, throttle linkage and downshift cable.

2) From rear of throttle body, remove fuel inlet line, fuel return line, brake booster line, MAP hose and AIR hose, noting positions for installation. Remove PCV, EVAP and EGR hoses from front of throttle body, noting positions. Remove 3 throttle body mounting screws, throttle body and gasket.

NOTE — Removal of throttle body is not necessary unless throttle shafts or throttle body replacement is required.

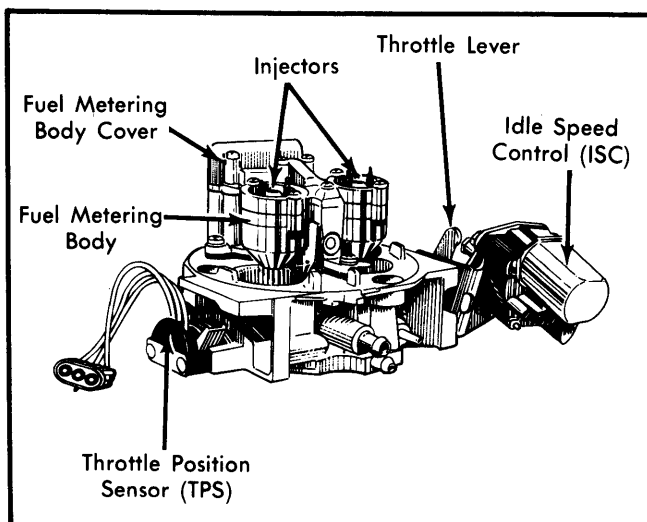

Fig. 3 Assembled View of Throttle Body Assembly

Installation — Position throttle body and new gasket on intake manifold. Install and tighten mounting screws. Connect fuel lines, vacuum hoses and electrical connections. Check and adjust ISC and TPS as required. See *ADJUSTMENTS* in this article.

THROTTLE POSITION SENSOR (TPS)

Removal — 1) Remove TPS electrical connector. Remove throttle body. Turn throttle body upside down and support assembly to prevent damage to injector connectors. Using a 5/16" drill bit, drill completely through both TPS access holes in base of throttle body to remove spot welds holding screws in place.

2) Remove and discard TPS attaching screws. Remove lock washers and retainers. Remove TPS from throttle body, noting location of TPS pick-up lever in relation to throttle shaft lever tang for installation reference.

Installation — Position TPS over throttle shaft with TPS pick-up lever following throttle lever tang. Install retainers, lock washers and 2 new screws. Tighten screws so TPS will move but is not loose. Install throttle body and reconnect electrical connector. Adjust TPS as required.

IDLE SPEED CONTROL ACTUATOR (ISC)

Removal & Installation — Disconnect ISC electrical connector. Remove 2 ISC mounting screws and ISC. To install, reverse removal procedure and adjust ISC as required.

NOTE — The ISC is calibrated at the factory and should not be disassembled. Replace as complete assembly only. Do not soak ISC in carburetor cleaner. Remove ISC from throttle body before cleaning throttle body.

INJECTORS & PRESSURE REGULATOR

Removal — Disconnect harness connectors from injectors. Remove 8 screws securing pressure regulator and fuel metering cover to throttle body and remove cover and regulator. With a lifting-twisting motion, carefully remove injectors. Discard upper and lower "O" rings being careful not to lose upper "O" ring back-up washer.

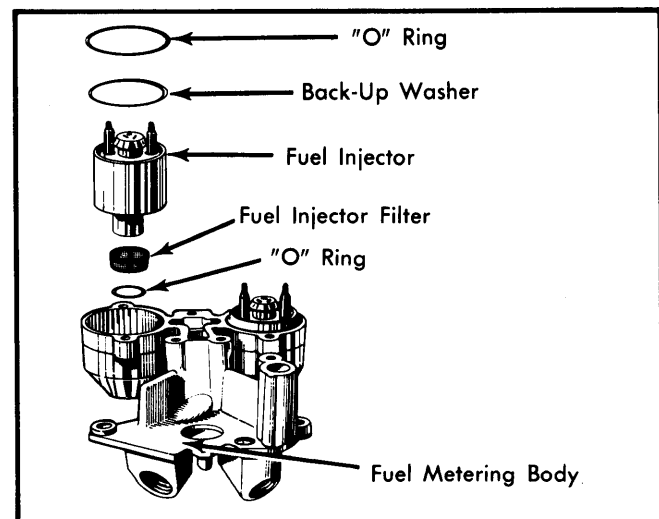

Fig. 4 Exploded View of Injector Components

GENERAL MOTORS DIGITAL FUEL INJECTION (Cont.)

Installation — Lubricate and install new "O" rings. Position injectors in fuel metering body with connectors aligned in a "cross-car" orientation. Install fuel metering cover assembly and retaining screws. Tighten screws evenly and install harness connectors.

NOTE — DO NOT remove 4 fuel pressure regulator screws from fuel metering cover. Fuel pressure regulator and fuel metering cover are serviced as an assembly only. Do not soak fuel metering cover in carburetor cleaner as fuel pressure regulator diaphragms and gaskets will be damaged.

FUEL METERING BODY

Removal & Installation — Remove throttle body. Remove fuel inlet and outlet line fitting nuts and gaskets from fuel metering body. Remove 3 retaining screws, lock washers, metering body and gasket. To install, reverse removal procedure and use new gasket.

NOTE — DO NOT remove fuel distribution skirt retaining screw. Skirt is integral part of throttle body and is not serviced separately.

MANIFOLD ABSOLUTE PRESSURE SENSOR (MAP) & BAROMETRIC PRESSURE SENSOR (BARO)

Removal — Remove right side lower instrument panel and glove box liner. Disconnect harness connectors from both sensors and vacuum hose from MAP sensor. Remove screw holding ground strap to mounting bracket and remove mounting bracket screws. Remove sensors and bracket as an assembly.

Installation — Reverse removal procedure and note MAP sensor has female connector on sensor and BARO sensor has male connector on sensor. Reinstall glove box liner and lower instrument panel.

COOLANT TEMPERATURE SENSOR

Removal — Drain radiator until coolant level is below that of sensor. Remove alternator (if necessary to gain access to sensor). Disconnect harness connector from sensor and remove sensor from block.

Installation — Apply non-hardening sealer to threads of sensor and install sensor. Reconnect harness connector and install alternator. Refill radiator.

MANIFOLD AIR TEMPERATURE SENSOR (MAT)

Removal & Installation — Remove sensor from manifold (directly in front of throttle body). When installing, coat threads with a non-hardening sealer.

ADJUSTMENTS

NOTE — After any adjustment procedure, "CHECK ENGINE" light may glow and trouble code will be stored in ECM. Refer to "GENERAL MOTORS DFI CONTROL SYSTEM" in Computerized Engine Controls section for more information.

THROTTLE POSITION SENSOR (TPS), MINIMUM AIR RATE, IDLE SPEED CONTROL (ISC)

NOTE — Throttle position sensor adjustment is preset at the factory and spot welds are used to prevent tampering. This adjustment is critical and must be accurately performed to assure proper vehicle performance.

1) Remove air cleaner, start engine and warm engine to normal operating temperature. Turn air conditioner off. Connect tachometer to engine. Using a digital volt/ohmmeter (J-29125), connect positive lead to harness test point "A" (circuit No. 417 — Dark Blue wire). Connect negative lead to harness test point "B" (circuit No. 476 — Black/White wire). See Fig. 5

2) Select 2V DC scale on volt/ohmmeter and disconnect "Set Timing" connector (DO NOT GROUND). Open throttle to 1500 RPM and retract ISC motor by pressing plunger in. When ISC motor fully retracts, disconnect ISC connector and then release throttle.

NOTE — Disconnecting "Set Timing" connector by-passes distributor and ECM to allow setting of TPS. "Set Timing" connector is located in wiring harness near ISC. Refer to CADILLAC DFI WIRING DIAGRAM in Wiring Diagrams section for location of connector.

3) Jumper ISC harness connector pins "A" and "B" together. ISC plunger should not touch throttle lever when connector pins are jumped together. If contact is noted, turn ISC plunger in with pliers until plunger clears throttle lever. Minimum air (idle) speed should be 400 RPM for California Eldorado and Seville and 375 RPM for all other models. Adjust throttle stop screw to provide correct RPM, if necessary.

4) With engine idling at correct RPM, volt/ohmmeter should read .45-.55 volts. If not, remove throttle body and drill out TPS spot welds. See THROTTLE POSITION SENSOR (TPS) under Removal & Installation. Loosen retaining screws enough to permit rotation of TPS. Remount throttle body, repeat steps 1) through 3) and adjust TPS lever position until volt/ohmmeter reading is correct. Tighten retaining screws and recheck reading.

5) Turn ignition off for 10 seconds. Remove jumper and reconnect ISC motor only. Start engine and allow ISC motor to extend to control idle speed.

6) Turn ignition off. ISC motor should move to extended position to prepare for restart. Disconnect TPS connector. Turn ignition on for 10 seconds and observe ISC plunger movement. When ISC plunger is fully extended to mechanical limit, turn ignition off.

7) When ISC plunger is fully extended, disconnect ISC connector and jumper ISC harness pins "A" and "B" together. Reconnect TPS. Start engine. Engine idle should be 1500-1700 RPM. If not, turn ISC plunger to set idle speed. Disconnect all test equipment, reconnect all connections and connect "Set Timing" connector.

1981 Fuel Injection

GENERAL MOTORS DIGITAL FUEL INJECTION (Cont.)

8) Turn engine off for 10 seconds. Start engine and check ISC motor for proper operation. Turn ignition off for 10 seconds. ISC motor should move to extended position. If ISC ratcheting noise is heard (or felt in accelerator pedal) with ignition on or off, readjust ISC motor by turning plunger out 1/2 turn at a time until noise stops. Repeat this step to check for noise.

TIGHTENING SPECIFICATIONS	
Application	Ft. Lbs.
Throttle Body Mounting Screws	15
Temperature Sensors	15
Fuel Filter	15

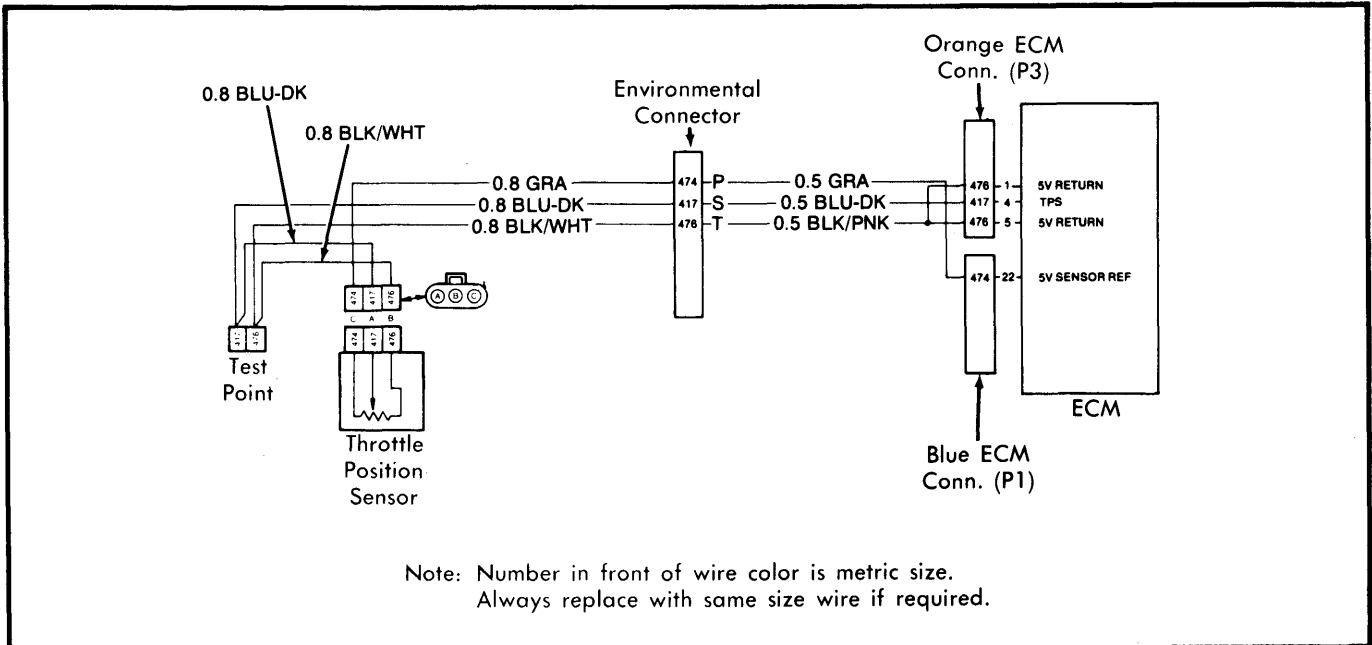

Fig. 5 DFI Throttle Position Sensor (TPS) Circuit

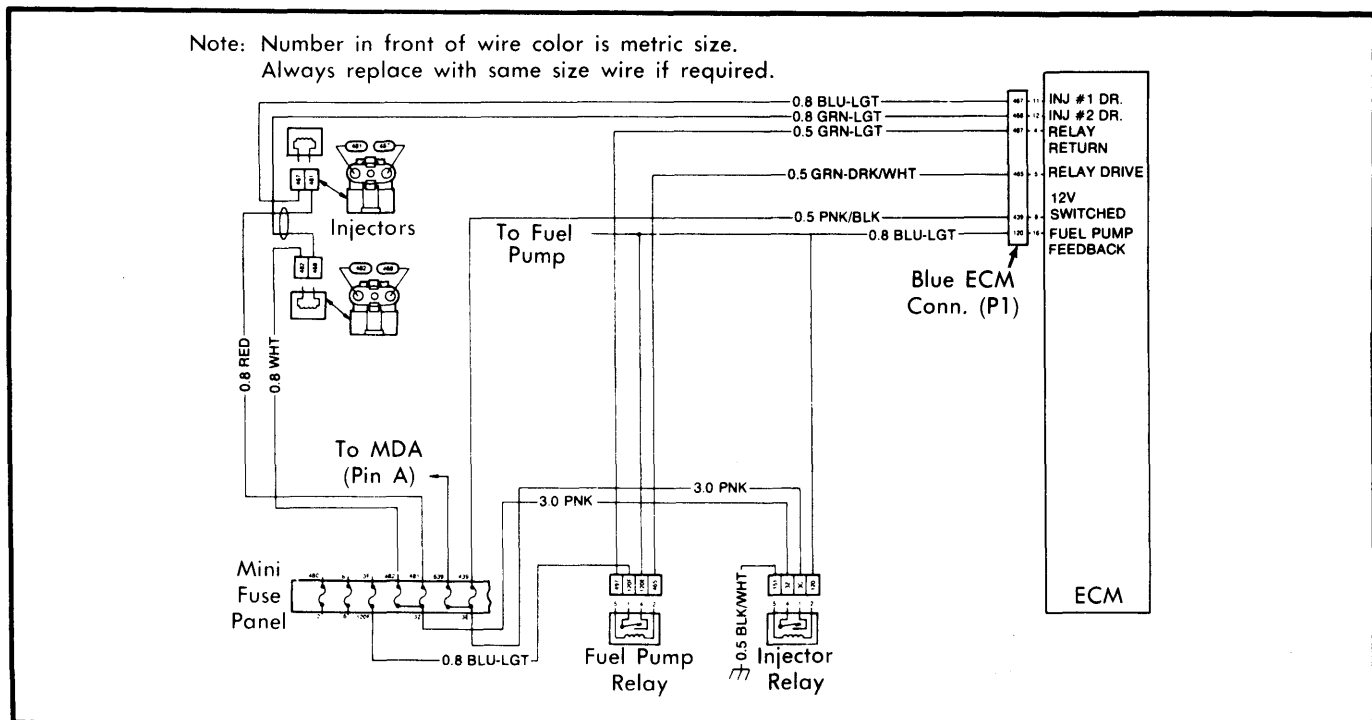

Fig. 6 DFI Fuel Pump and Injector Circuit