

1981 Rochester Carburetors

ROCHESTER MODELS 2SE & E2SE 2-BARREL

CARBURETOR APPLICATION

DESCRIPTION

AMERICAN MOTORS

Application	Rochester Carb. No.
151" 4-Cylinder Man. Trans. Federal (2SE)	
Eagle	17081791
Spirit & Concord Without A/C	17081792
With A/C	17081793
California (E2SE)	17081196
151" 4-Cylinder Auto. Trans. Federal (2SE)	
Eagle	17081790
Spirit & Concord Without A/C	17081794
With A/C	17081795
California (E2SE)	17081797

GENERAL MOTORS

Application	Rochester Carb. No.
151" 4-Cylinder Man. Trans. (E2SE)	
Without A/C	17081671
With A/C	17081673
151" 4-Cylinder Auto. Trans. (E2SE)	
Without A/C	17081670
With A/C	17081672
173" V6 Man. Trans. (E2SE)	
Without A/C	17081651
With A/C	17081653
173" V6 Auto. Trans. (E2SE)	
Federal	
Without A/C	17081650
With A/C	17081652
California	
Without A/C	17081740
With A/C	17081742
173" V6 Auto. Trans. High Output (E2SE)	
Federal	
Without A/C	17081656
With A/C	17081658
California	
Without A/C	17081746
With A/C	17081748
173" V6 Man. Trans. High Output (E2SE)	
Federal	
Without A/C	17081657
With A/C	17081659
California	
Without A/C	17081747
With A/C	17081749

CARBURETOR IDENTIFICATION

The Rochester 2SE and E2SE carburetor numbers are stamped vertically on the float bowl next to the vacuum tube. If float bowl is replaced, follow manufacturer's instructions contained in service package, so that part number is transferred to new float bowl.

The Rochester Varajet Carburetor models 2SE and E2SE are 2-stage, 2-barrel downdraft carburetors. The primary stage consists of a triple venturi with a 35 mm bore. The secondary stage has a 46 mm bore and is equipped with an air valve with a single tapered metering rod. Both are equipped with integral, electronically-activated chokes, a choke vacuum break diaphragm and an idle speed solenoid. The 2SE model is used on American Motors Federal models.

NOTE — A single primary vacuum break unit is used on 4-cylinder models, but both a primary and secondary vacuum break are used on V6 models.

The E2SE model is used by General Motors in conjunction with the Computer Command Control system and by American Motors California models with the C-4 Feedback System. The E2SE model is equipped with an electrically-operated mixture control solenoid, mounted on the air horn and extending into the fuel bowl. Fuel metering is controlled by the mixture control solenoid plunger opening and closing the fuel passage to the main metering jet.

When the plunger is in the down position (lean), fuel metering is controlled by a factory-adjusted lean mixture screw located in the float bowl. When plunger is in the up position (rich), additional fuel is metered to the main fuel well through the factory-adjusted rich mixture screw located at the end of the fuel supply channel in the float bowl.

Air is also metered by the plunger and is further metered by a factory-adjusted idle air bleed screw. The system constantly monitors exhaust gas oxygen content and other engine conditions and adjusts air/fuel mixtures accordingly.

V6 models with E2SE carburetors use a throttle position sensor (TPS) to electrically signal the ECM various throttle positions as changes occur. The ECM then "holds" the last known air/fuel mixture ratio or activates the mixture control solenoid to adjust the mixture as needed.

On 4-cylinder models without air conditioning and on V6 engines with air conditioning and/or manual transmission, an idle speed solenoid (ISS) is used to position the primary throttle valve to obtain idle speed requirements. On 4-cylinder engines with air conditioning, an idle speed control (ISC) motor controlled by the ECM is used to control idle speed.

All 2SE and E2SE models use non-bendable vacuum break links and a special cap which is snapped in place over the vacuum break adjustment screw. All models, except American Motors vehicles with 2SE carburetors, use a non-adjustable heavy duty accelerator pump lever and link, making adjustment unnecessary.

Other tamper-resistant features include factory-adjusted rich and lean mixture screws, idle air bleed screw and TPS adjusting screws that require either special tools or are covered with hardened steel plugs. The idle speed solenoid has a special notched plunger head to prevent field readjustment. Do not attempt to use ISS or ISC to set curb idle speed.

CAUTION — NO ATTEMPT should be made to adjust screws except when required by a Computer Command Control System performance check, major overhaul, or replacement of the air horn, float bowl or throttle body.

Special rivets with retainers are used on the choke thermostatic cover and coil assembly and must not be removed unless major

ROCHESTER MODELS 2SE & E2SE 2-BARREL (Cont.)

carburetor overhaul or choke cover and coil assembly or choke housing replacement is required. Then a special kit with service rivets must be installed.

ADJUSTMENT

HOT (SLOW) IDLE RPM

See appropriate article in *TUNE-UP SERVICE PROCEDURES*.

COLD (FAST) IDLE RPM

See appropriate article in *TUNE-UP SERVICE PROCEDURES*.

IDLE MIXTURE

See appropriate article in *TUNE-UP SERVICE PROCEDURES*.

IDLE AIR BLEED VALVE (E2SE ONLY)

► ANGLE GAUGE ADJUSTMENT TOOL

Manufacturer recommends that some carburetor adjustments be performed using a choke valve angle gauge (Kent-Moore tool no. J-26701). While preparations and actual adjustments may vary with each individual adjustment, the procedure for using the angle gauge to check the choke valve angle remains the same. Use the following procedure to perform adjustments requiring the use of the choke angle gauge. See Fig. 1.

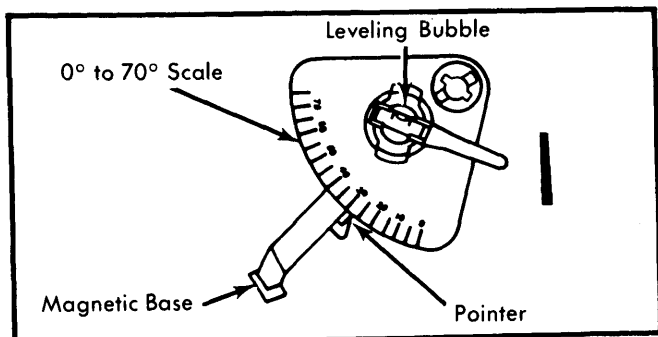

Fig. 1 Choke Valve Angle Gauge

- 1) Rotate degree scale on angle gauge so that 0° mark is opposite pointer.
- 2) With choke valve closed, place angle gauge magnet squarely on choke valve.
- 3) Rotate leveling bubble on angle gauge until it is centered.
- 4) Rotate degree scale until specified degree mark is opposite pointer.
- 5) Now perform individual adjustment preparations as outlined in the following carburetor adjustments requiring angle gauge. If bubble is centered, adjustment is correct. If not, adjust carburetor as outlined.

FLOAT LEVEL

- 1) Remove air horn and gasket from float bowl. Hold float retainer firmly down while pushing float down against needle. See Fig. 2.

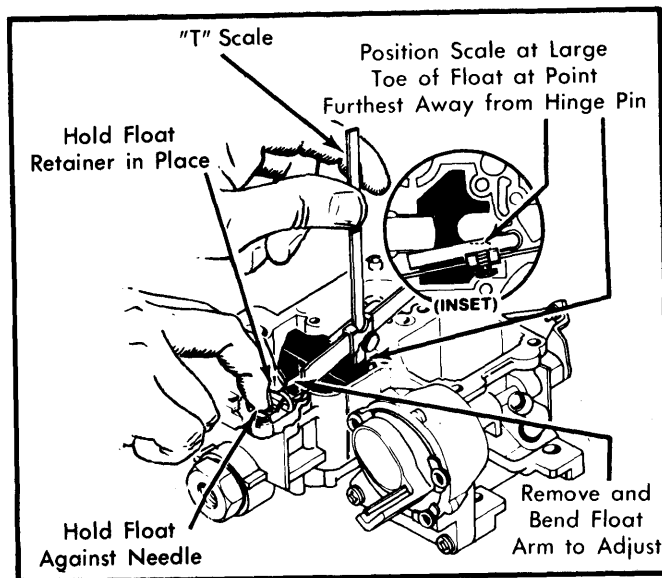

Fig. 2 Adjusting Float Level

- 2) Position a "T" scale over large toe of float at point furthest away from float hinge pin. Measure distance from float bowl casting to float.

NOTE — A new set of external float gauges (J9789-135) are available for 2SE and E2SE carburetors. By selecting proper gauge for specific carburetor being checked, a simple "On Car" check can be made without removing air horn from float bowl. Just remove vent stack and air horn screw and insert gauge in air horn screw hole. Let it float freely.

- 3) To adjust, remove float and bend float arm. Check to make sure float is correctly aligned after adjustment.

ACCELERATOR PUMP

NOTE — If carburetor has a clip retaining pump rod in pump lever, no adjustment is required. If connection is "clipless", pump adjustment should not be changed from original factory setting. See Fig. 3. Adjustment should only be made if specified setting is changed. Pump lever is manufactured from hardened steel, making it difficult to bend. Pump arm should not be removed to make adjustment unless absolutely necessary.

- 1) Close throttle valves completely. Make sure fast idle speed screw is off fast idle cam. See Fig. 3.
- 2) Using a "T" scale, measure accelerator pump specified distance from cast surface of air horn to top of pump stem.
- 3) To adjust, remove pump lever screw and washer. Remove pump lever by rotating lever and removing from pump rod. Secure lever in a vise and bend end of lever at small segment.
- 4) Install pump lever, washer and retaining screw. Recheck pump adjustment, and when correct, tighten retaining screw. Open and close throttle and check for free linkage movement and pump lever alignment.

1981 Rochester Carburetors

ROCHESTER MODELS 2SE & E2SE 2-BARREL (Cont.)

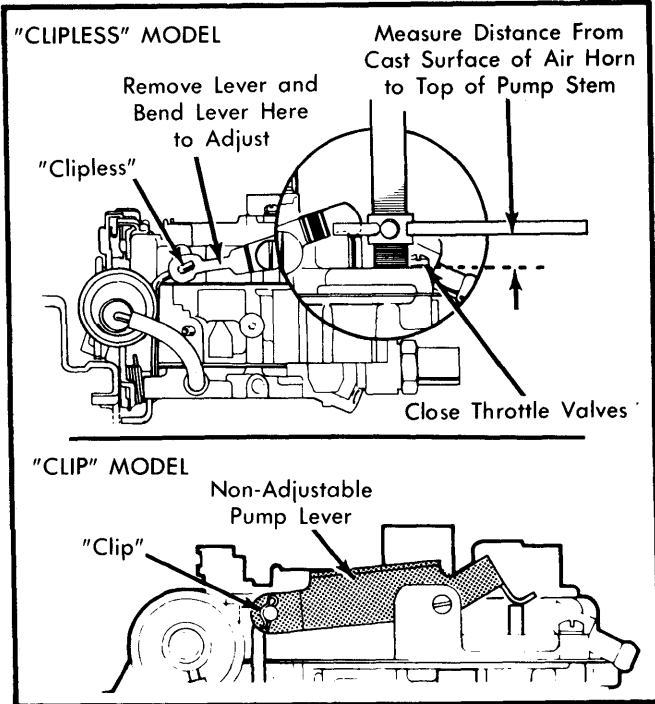

Fig. 3 Adjusting Accelerator Pump

CHOKE COIL LEVER

NOTE — Do not remove rivets and retainers holding choke cover and coil assembly in place unless necessary to check choke coil lever adjustment. If rivets and cover are removed, a new rivet service kit must be installed.

1) If necessary, remove rivets and choke thermostatic cover from choke housing. Place fast idle screw on high step of fast idle cam. See Fig. 4.

2) Push in on intermediate choke lever until choke valve is fully closed.

3) Insert a specified drill or pin gauge in hole provided in choke housing. Choke lever inside housing should just touch drill or pin gauge.

4) To adjust, bend intermediate choke rod at point shown in illustration. Reinstall choke cover and adjust.

CHOKE ROD (FAST IDLE CAM)

NOTE — Choke coil lever adjustment must be correct and fast idle must be adjusted before proceeding. This adjustment makes use of choke angle gauge. See instructions at beginning of Adjustments.

1) Place fast idle speed screw on second step of fast idle cam against shoulder of highest step. See Fig. 5.

2) Close choke valve by pushing on intermediate choke lever. Push vacuum break lever toward open choke until lever is against rear tang on choke lever.

3) Bubble on choke angle gauge should be centered with specified degree mark opposite pointer.

4) To adjust, bend fast idle cam rod at point shown in illustration until bubble of choke valve angle gauge is centered.

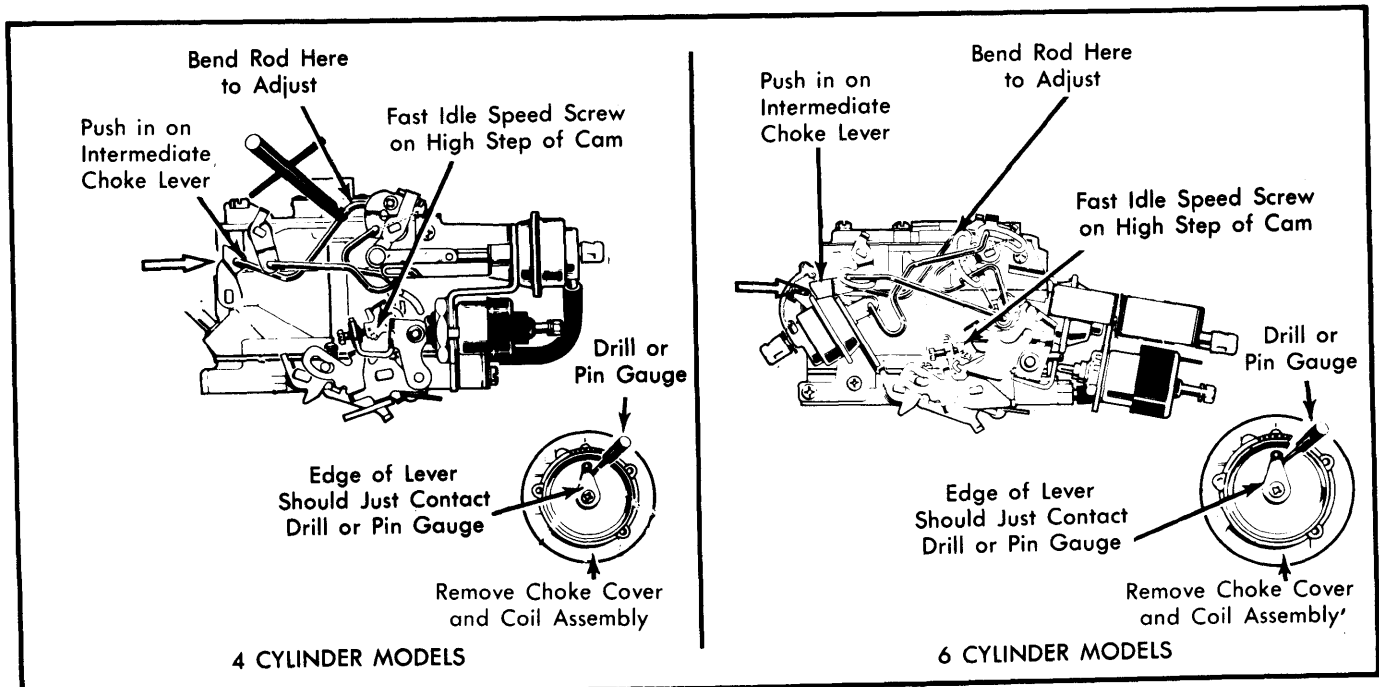

Fig. 4 Adjusting Choke Coil Lever

ROCHESTER MODELS 2SE & E2SE 2-BARREL (Cont.)

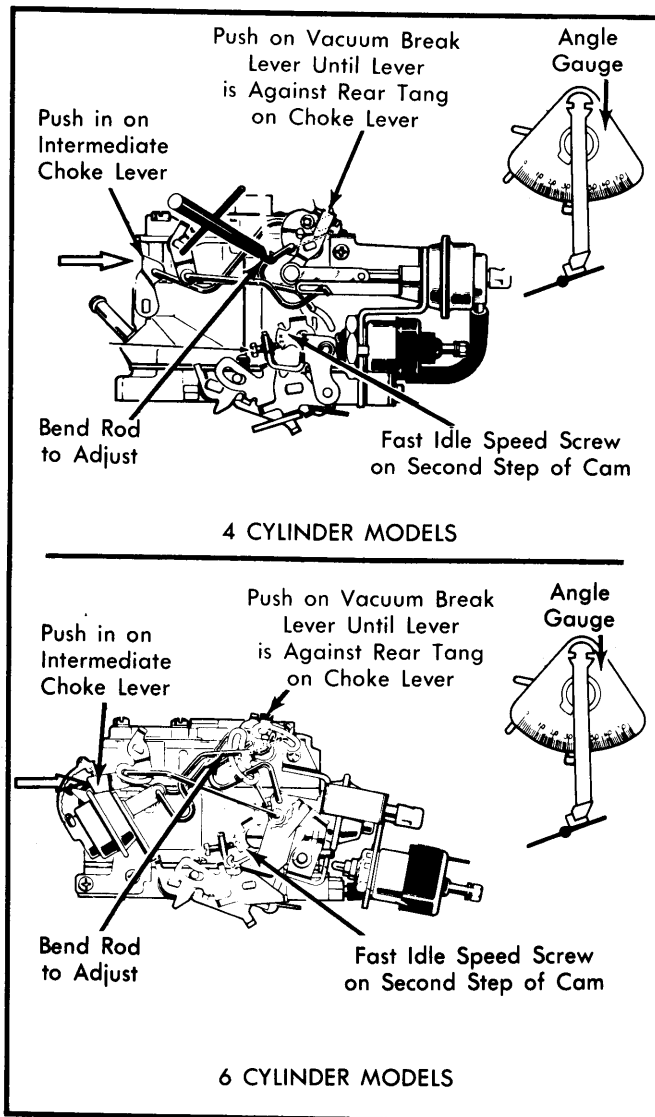

Fig. 5 Adjusting Choke Rod (Fast Idle Cam)

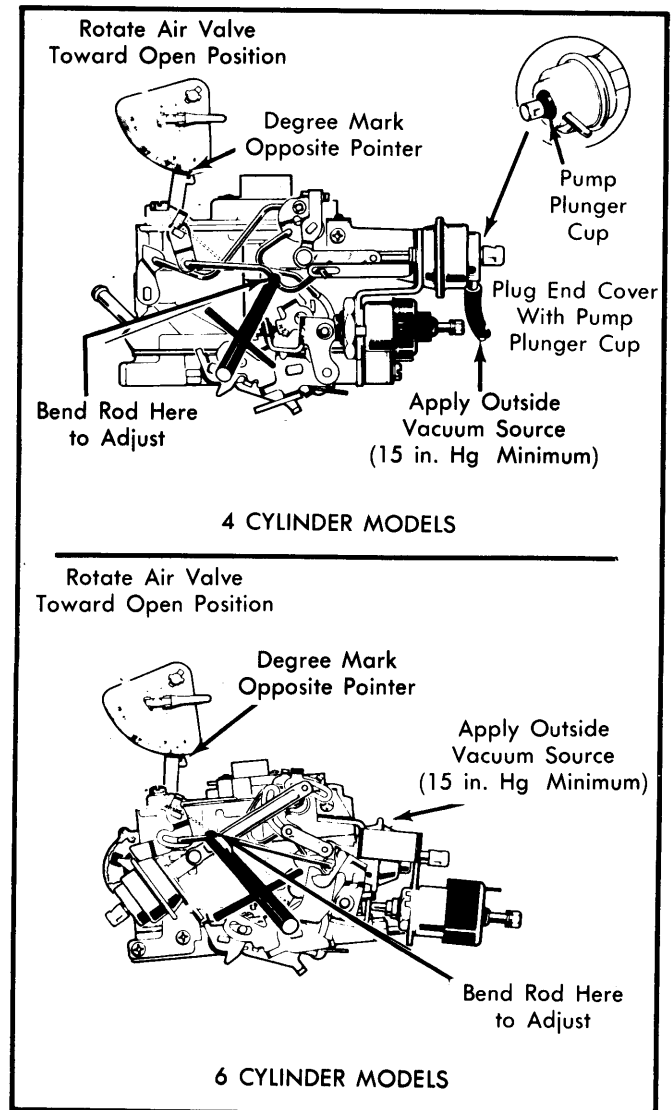

Fig. 6 Adjusting Air Valve Rod

AIR VALVE ROD

NOTE — This adjustment is made by using the choke valve angle gauge. See procedure at beginning of Adjustments.

1) Using an outside vacuum source of at least 15 in. Hg, seat primary choke vacuum break diaphragm. Close air valve, mount and adjust angle gauge. See Fig. 6.

NOTE — Plug end cover on 4-cylinder models, using tape or accelerator pump plunger cup. Cup must be removed after adjustment is completed.

2) Apply light opening pressure to air valve shaft. Set to specified angle by bending air valve rod at a point near its connection to primary vacuum break (models equipped with primary vacuum break only) or at a point near its connection to air valve lever (models equipped with primary and secondary vacuum breaks).

PRIMARY VACUUM BREAK

NOTE — This adjustment is performed using the choke valve angle gauge, see procedure at beginning of Adjustments.

1) Remove primary choke vacuum break from carburetor, place bracket in a vise, and carefully grind off adjustment screw cap. Using an outside vacuum source, seat choke vacuum break diaphragm. See Fig. 7. Be sure air valve rod permits seating and does not interfere.

NOTE — Plug end cover on 4-cylinder models, using tape or accelerator pump plunger cup. Cup must be removed after adjustment is completed. Be sure plunger bucking spring is compressed and seated (plunger fully extended), if so equipped.

2) Close choke valve by pushing on intermediate choke lever. Bubble on choke valve angle gauge should be centered with specified degree mark opposite pointer.

3) To adjust, use a $\frac{1}{8}$ " hex wrench to turn screw in rear cover until bubble is centered. Remove cup after adjustment and apply RTV silicone sealant over screw head to seal setting.

1981 Rochester Carburetors

ROCHESTER MODELS 2SE & E2SE 2-BARREL (Cont.)

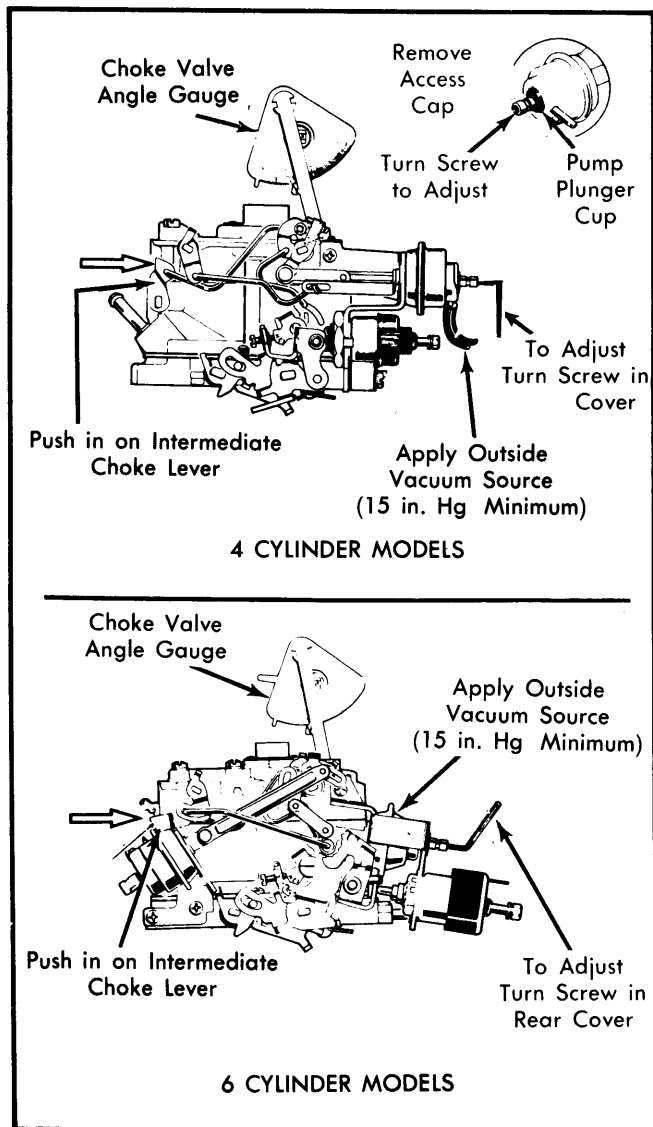

Fig. 7 Primary Vacuum Break Adjustment

AUTOMATIC CHOKE

NOTE — Choke coil cover is retained on housing with rivets to prevent tampering with factory adjustment. If necessary to remove cover, refer to Disassembly and Reassembly procedures in this Section.

CHOKE UNLOADER

NOTE — This adjustment is performed using the choke valve angle gauge, see procedure at beginning of adjustments.

1) Automatic choke should be to specified setting. Do not adjust setting unless carburetor is to be overhauled or unless choke coil lever adjustment is necessary. Hold primary throttle valve wide open. See Fig. 8.

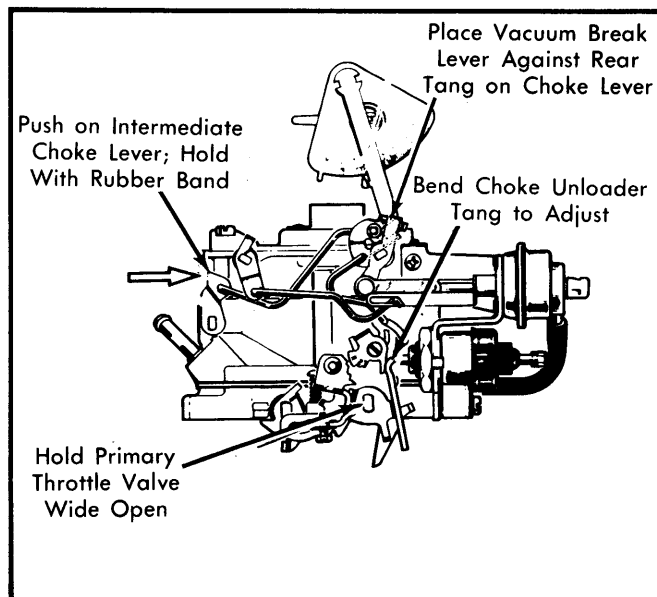

Fig. 8 Choke Unloader Adjustment

2) If engine is warm, close choke valve by pushing in on intermediate choke lever. Hold in position with rubber band.

3) Place vacuum break lever against rear tang on choke lever (toward open choke). To adjust, bend tang on throttle lever until bubble is centered.

4) Remove gauge and reinstall choke cover and coil assembly if previously removed. Install service rivet and retainer kit.

SECONDARY VACUUM BREAK (V6 ONLY)

NOTE — This adjustment is made using the choke valve angle gauge, see procedure at beginning of adjustments.

1) Remove secondary choke vacuum break from carburetor, place bracket in a vise, and carefully grind off adjustment screw cap. Using an outside vacuum source, seat secondary choke vacuum break diaphragm. See Fig. 9.

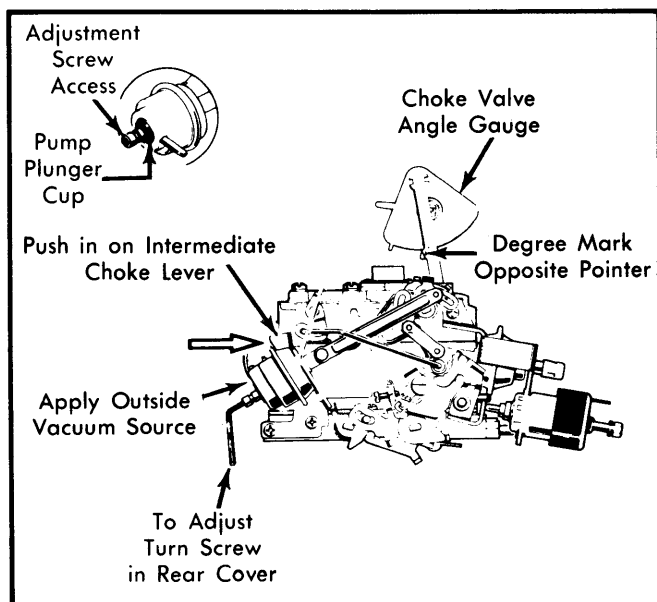

Fig. 9 Secondary Vacuum Break Adjustment

ROCHESTER MODELS 2SE & E2SE 2-BARREL (Cont.)

2) Close choke valve by pushing on intermediate choke lever. Make sure bucking spring on diaphragm plunger (if equipped) is fully compressed and seated.

3) Bubble on choke valve angle gauge should be centered with specified degree mark opposite pointer.

4) To adjust, use 1/8" hex wrench to turn screw in rear cover until bubble is centered. Remove cup or tape after adjustment. Apply RTV silicone sealant over screw head to seal setting.

SECONDARY LOCK OUT

1) Hold choke valve wide open by pulling out (counter-clockwise) on intermediate choke lever. See Fig. 10.

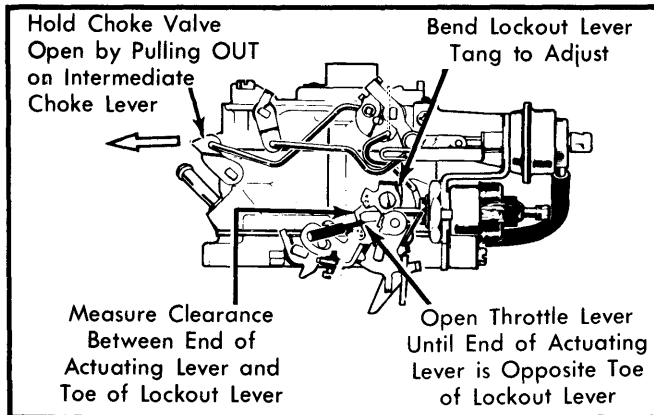

Fig. 10 Adjusting Secondary Throttle Lockout

2) Open throttle valves until end of secondary actuating lever is opposite toe of lockout lever.

3) Measure specified clearance between end of actuating lever and toe of lockout lever. Measurement can be checked using a drill or pin gauge of specified size.

4) To adjust, bend lockout lever tang contacting fast idle cam.

IDLE SPEED CONTROL

NOTE — Do not attempt to set curb idle speed on vehicles with Computer Command Control by adjusting idle speed control. See Fig. 11. Idle speeds are computer-controlled. For adjustment procedures see Tune-Up Section.

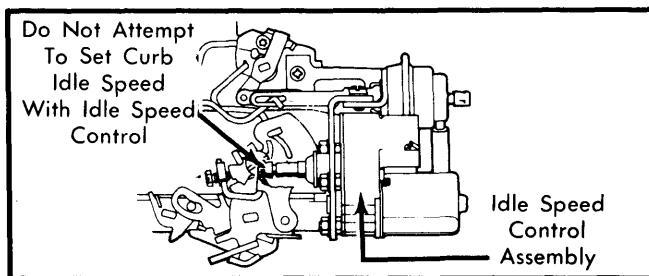

Fig. 11 Non-Adjustable Idle Speed Control

FAST IDLE BENCH ADJUSTMENT

Place fast idle screw on highest step of fast idle cam. See Fig. 12. Turn fast idle screw in or out to just contact cam. Then turn screw in specified number of turns, as shown on emission control label.

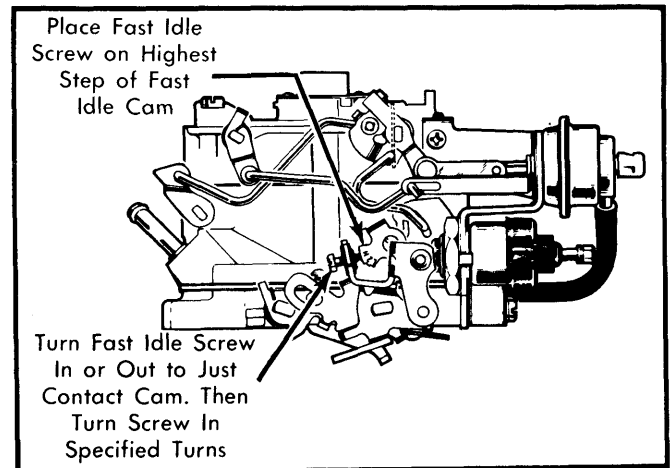

Fig. 12 Fast Idle Bench Adjustment

OVERHAUL

DISASSEMBLY

NOTE — Before disassembling carburetor, mount unit in a suitable holding fixture to prevent damage to throttle valves or linkage.

Air Horn — 1) Bend back tabs on idle speed solenoid lock washer. Remove large solenoid retaining nut. Care must be taken when loosening nut to avoid damaging linkage, solenoid bracket, throttle lever or vacuum break. Remove solenoid and washer from bracket.

NOTE — On models with Idle Speed Control, remove control bracket (to vacuum break) attaching screws. Remove control and bracket as an assembly.

2) On 2SE models (NOT USING a clip to secure the accelerator pump rod), remove pump lever retaining screw from air horn. Rotate pump lever to remove from pump rod. On E2SE models (using a clip to secure pump rod), remove clip and remove pump rod from hole in pump lever.

CAUTION — DO NOT remove pump lever retaining screw from E2SE models using clip as pump rod retainer. Pump lever and washer must not be removed from air horn assembly on these models.

3) Remove hose from vacuum break assembly or assemblies. On 4-cylinder models, remove bracket attaching screws from air horn and throttle body. Then, rotate vacuum break and bracket assembly to disengage vacuum break link and air valve rod from vacuum break diaphragm plunger stem slots. On V6 models, remove bracket attaching screws from air horn only. Then, rotate vacuum break and bracket assembly to disengage vacuum break link from slot in vacuum break lever and air valve rod from slot in air valve lever.

4) If necessary to remove air valve rod from vacuum break on V6 models, remove and discard retaining clip from end of air valve. New retaining clip must be used on reassembly. Plastic bushing used on rod may be reused.

5) On V6 models, remove secondary side vacuum break and bracket assembly attaching screws from throttle body. Rotate bracket to remove vacuum break link from vacuum break lever slot.

6) Remove and discard retaining clip from intermediate choke rod at choke lever. Use a new retaining clip at reassembly.

ROCHESTER MODELS 2SE & E2SE 2-BARREL (Cont.)

Remove choke rod and bushing from choke lever. Bushing may be reused. If equipped, remove hot idle compensator valve screws. Remove valve and seal from air horn, discarding seal. Valve removal is necessary to gain access to short air horn-to-bowl attaching screw.

7) On E2SE models, remove 3 mixture control solenoid screws and remove mixture control solenoid using a light twisting motion. Remove and discard solenoid gasket, plunger seal and plunger seal retainer.

8) Remove all air horn-to-float bowl screws and lock washers. Remove vent and screen assembly. Rotate fast idle cam up as far as possible. Rotate air horn and tilt to disengage fast idle cam rod from slot in fast idle cam and pump rod from hole in pump lever.

9) Disconnect fast idle cam rod from choke lever by aligning tang on rod with slot in lever. Lift off air horn assembly.

10) On V6 models, remove TPS plunger by pushing through seal in air horn. Remove seal retainer and seal. Remove accelerator pump plunger seal from air horn.

NOTE — Use fingers only (no tools) when removing plunger to prevent damage to sealing surface. Use care in removing plunger seal retainer and plunger stem seal retainer to prevent damage to air horn. Discard seals and retainers.

11) It is not necessary to remove choke valve and shaft unless bent or damaged. Choke valve screws are staked in place. Staking must be removed before screws are removed.

Float Bowl — 1) Remove air horn gasket. Remove pump plunger and pump spring from pump well. Remove plastic filler block from float valve.

2) Remove float assembly and float valve, pulling up on retaining pin. Remove float needle seat, gasket and extended metering jet from float bowl. Use suitable tool (J-22769) or screwdriver that fully fits slot in top of jet.

3) On E2SE models, push up from bottom on electrical connector and remove TPS and connector from float bowl. Remove spring from bottom of TPS well in bowl. On 2SE models, press down on power piston stem and allow it to snap up. Repeat this until plastic retainer is dislodged and remove power piston and metering rod assembly.

4) Remove spring from power piston bore. If necessary to remove metering rod from hanger, compress spring on metering rod and align groove on rod with slot in holder. Care must be taken not to damage tip of metering rod.

5) Remove main metering jet using a screwdriver that fits tight in groove. Using a small slide hammer, remove plastic retainer holding pump discharge spring and check ball in place in float bowl. Discard retainer.

6) If it is necessary to remove the tamper-resistant choke cover and coil assembly, align a .125" (1/8") drill on choke cover retaining rivets and drill only enough to remove rivet heads. Remove rivets, choke cover and coil assembly. Remove screw from end of intermediate choke shaft in choke housing. Remove choke coil lever from shaft.

7) Slide intermediate choke shaft out of float bowl. Remove choke housing screws and remove choke housing. Remove fuel inlet nut, gasket, check valve/filter and spring.

8) Remove 4 screws securing throttle body to float bowl. Remove throttle body. Remove throttle body insulator gasket.

Throttle Body — 1) Hold throttle valves wide open. Disengage pump rod from throttle lever by rotating rod until tang on rod aligns with slot in lever.

2) Do not remove plug covering idle mixture screw unless it is necessary to replace mixture screw or normal soaking and air pressure fails to clean idle mixture passages. Remove curb idle and fast idle speed screws and springs if necessary.

NOTE — It is not necessary to disassemble throttle body any further. Throttle valve screws are permanently staked in. Do not remove idle mixture screw plug unless it is necessary to replace mixture screw or cleaning and air pressure fails to clean idle mixture passage. If necessary to remove, proceed as follows:

3) Invert throttle body and position on a holding fixture with manifold side up. Using a small hacksaw, make 2 small cuts, one on either side of mixture screw plug location. Position a small flat punch on throttle body between cuts.

4) Drive punch down and break out portion of throttle body between the 2 cuts. Hold punch at a 45° angle and drive out hardened steel plug.

NOTE — Plug will shatter when struck. Remove loose pieces to allow the use of adjusting tool (J-28706) or thin walled deep 3/16" socket to remove adjusting screw and spring.

5) Turn mixture screw in carefully, counting turns needed to seat screw. Record number to be used in reassembly, then remove mixture screw.

CLEANING & INSPECTION

- Use a regular carburetor cleaning solution. Soak components long enough to thoroughly clean all surfaces and passages of foreign matter.
- Do not soak any components containing rubber, leather or plastic. Definitely do not soak idle speed solenoid or control, mixture control solenoid, throttle position sensor, electric choke, diaphragms, pump plunger and plastic filler block. Plastic bushings in end of vacuum break link and air valve rod on 4-cylinder models will withstand normal cleaning.
- Remove any residue after cleaning by rinsing components in a suitable solvent.
- Blow out all passages with dry compressed air.

REASSEMBLY

NOTE — Use new gaskets and seals. Make sure new gaskets fit correctly and all holes are punched through and properly located.

To reassemble carburetor, reverse disassembly procedure and note the following:

1) Install fuel inlet needle pull clip over edge of flat on float arm facing float. Do not hook clip in holes in float arm.

ROCHESTER MODELS 2SE & E2SE 2-BARREL (Cont.)

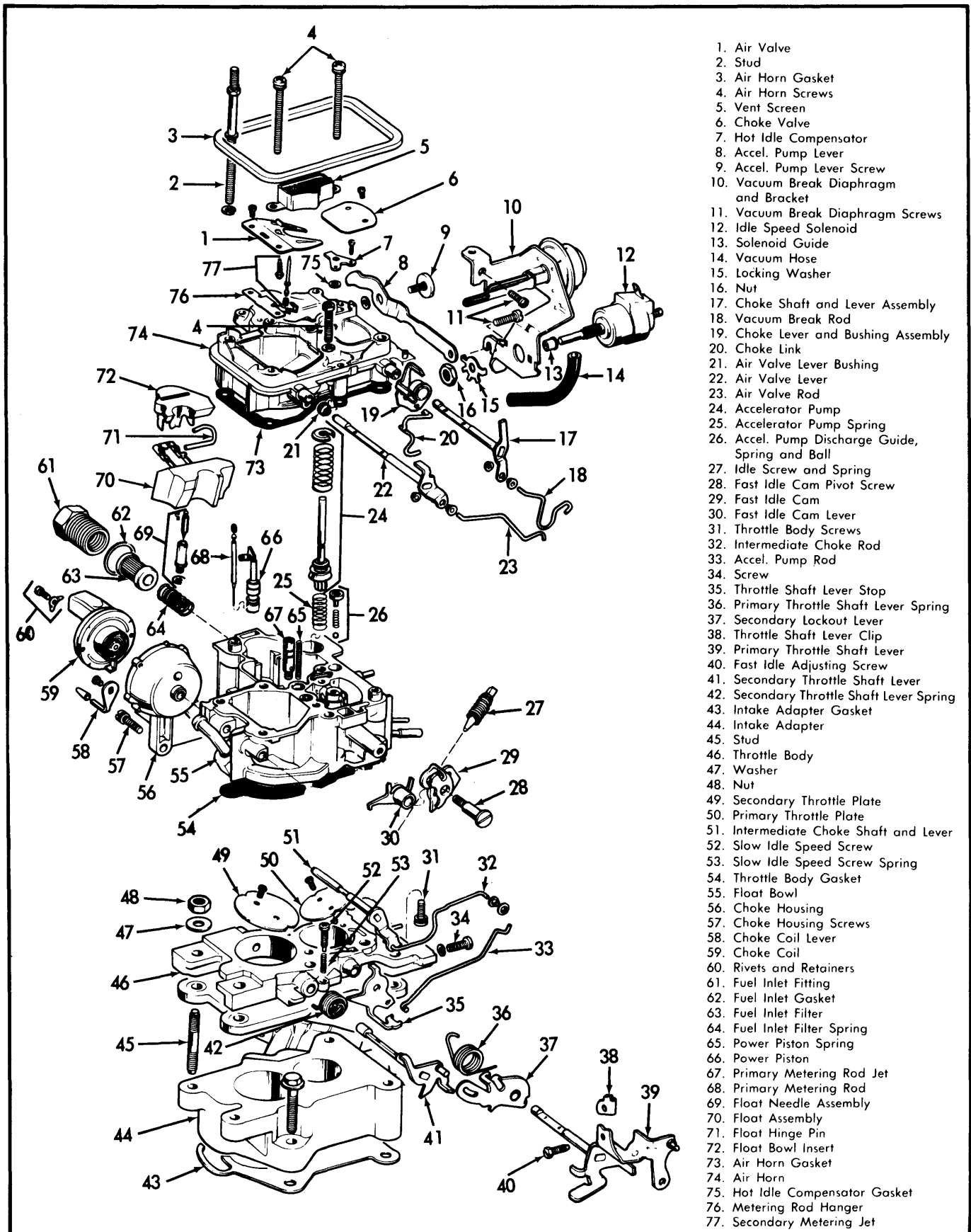

1. Air Valve
2. Stud
3. Air Horn Gasket
4. Air Horn Screws
5. Vent Screen
6. Choke Valve
7. Hot Idle Compensator
8. Accel. Pump Lever
9. Accel. Pump Lever Screw
10. Vacuum Break Diaphragm and Bracket
11. Vacuum Break Diaphragm Screws
12. Idle Speed Solenoid
13. Solenoid Guide
14. Vacuum Hose
15. Locking Washer
16. Nut
17. Choke Shaft and Lever Assembly
18. Vacuum Break Rod
19. Choke Lever and Bushing Assembly
20. Choke Link
21. Air Valve Lever Bushing
22. Air Valve Lever
23. Air Valve Rod
24. Accelerator Pump
25. Accelerator Pump Spring
26. Accel. Pump Discharge Guide, Spring and Ball
27. Idle Screw and Spring
28. Fast Idle Cam Pivot Screw
29. Fast Idle Cam
30. Fast Idle Cam Lever
31. Throttle Body Screws
32. Intermediate Choke Rod
33. Accel. Pump Rod
34. Screw
35. Throttle Shaft Lever Stop
36. Primary Throttle Shaft Lever Spring
37. Secondary Lockout Lever
38. Throttle Shaft Lever Clip
39. Primary Throttle Shaft Lever
40. Fast Idle Adjusting Screw
41. Secondary Throttle Shaft Lever Spring
42. Secondary Throttle Shaft Lever Spring
43. Intake Adapter Gasket
44. Intake Adapter
45. Stud
46. Throttle Body
47. Washer
48. Nut
49. Secondary Throttle Plate
50. Primary Throttle Plate
51. Intermediate Choke Shaft and Lever
52. Slow Idle Speed Screw
53. Slow Idle Speed Screw Spring
54. Throttle Body Gasket
55. Float Bowl
56. Choke Housing
57. Choke Housing Screws
58. Choke Coil Lever
59. Choke Coil
60. Rivets and Retainers
61. Fuel Inlet Fitting
62. Fuel Inlet Gasket
63. Fuel Inlet Filter
64. Fuel Inlet Filter Spring
65. Power Piston Spring
66. Power Piston
67. Primary Metering Rod Jet
68. Primary Metering Rod
69. Float Needle Assembly
70. Float Assembly
71. Float Hinge Pin
72. Float Bowl Insert
73. Air Horn Gasket
74. Air Horn
75. Hot Idle Compensator Gasket
76. Metering Rod Hanger
77. Secondary Metering Jet

Fig. 13 Exploded View of Rochester 2SE 2-Barrel Carburetor

1981 Rochester Carburetors

ROCHESTER MODELS 2SE & E2SE 2-BARREL (Cont.)

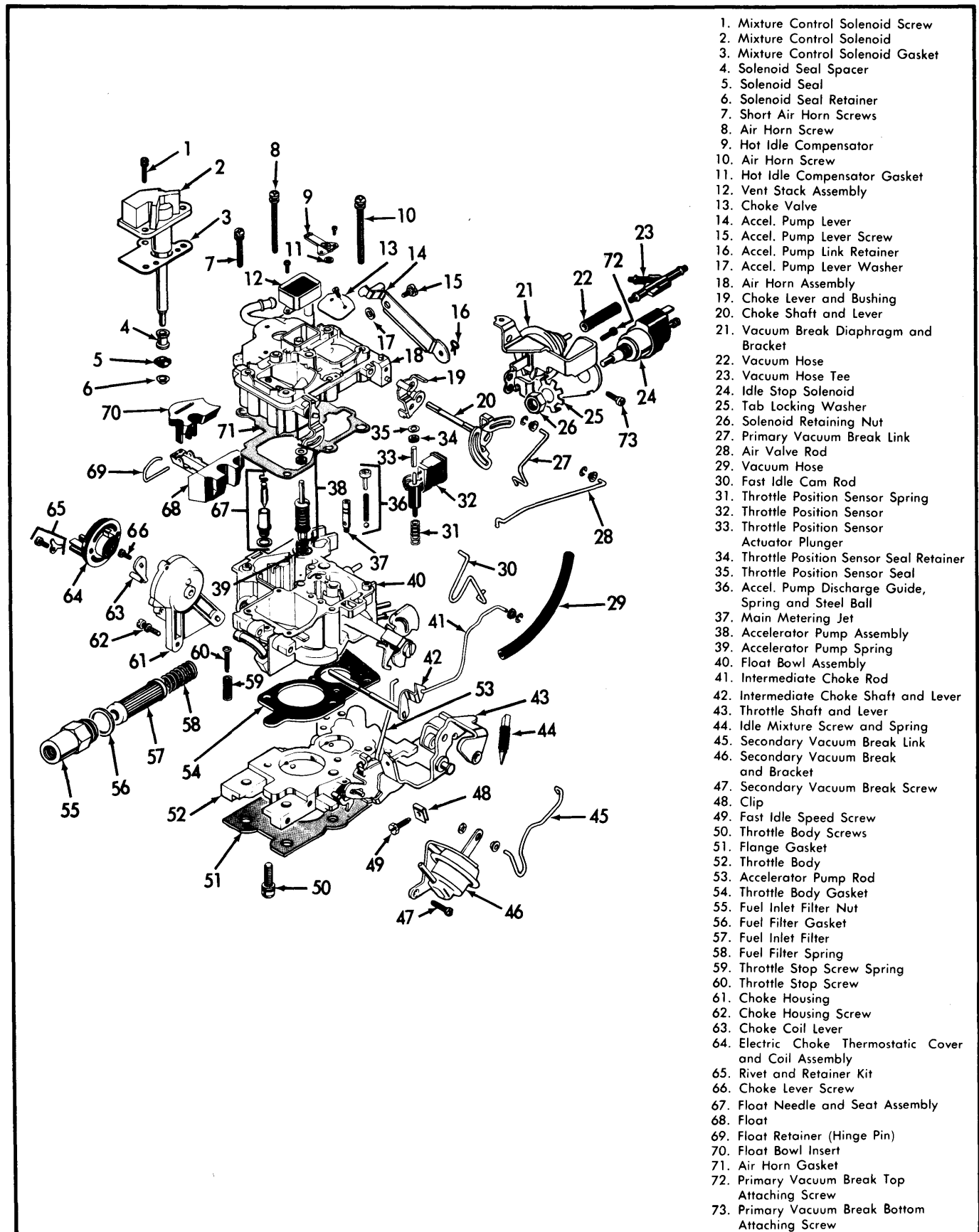

Fig. 14 Exploded View of Rochester E2SE 2-Barrel Carburetor

ROCHESTER MODELS 2SE & E2SE 2-BARREL (Cont.)

- 2) After throttle body is installed on float bowl, make sure secondary lockout tang is in correct position to engage secondary lockout lever.
- 3) Install new accelerator pump discharge check ball and spring plastic retainer. Insert end of retainer in spring and place in position in float bowl. Lightly tap retainer into position until it is flush in float bowl.
- 4) Make sure holes in fuel filter face toward fuel inlet fitting when filter is installed.
- 5) Some linkage retaining clips are dished. Make sure portion of clip that bends outward is toward end of rod. Make sure clip makes full contact with rod.
- 6) Place fast idle screw on high step of fast idle cam. Install choke coil cover, aligning notch in cover with raised boss on housing cover flange.

NOTE — If choke cover and coil assembly was removed from housing, a service rivet kit must be installed to restore tamper-resistant feature.

CAUTION — On E2SE models, be sure coil pick-up lever is located inside choke coil tang. Also, on electric chokes, the ground contact is provided by a metal plate at rear of choke cover assembly. Do not install a choke cover gasket between electric choke assembly and choke housing.

7) Install air horn screws, noting location and type of screw for correct installation. Tighten all screws evenly, securely and in order shown in Fig. 11.

8) On E2SE models, install mixture control solenoid seal on solenoid stem. Using a 3/16" socket and hammer, lightly tap retainer in place, on stem, leaving a slight clearance between retainer and seal. Apply silicone grease to seal before installation of solenoid.

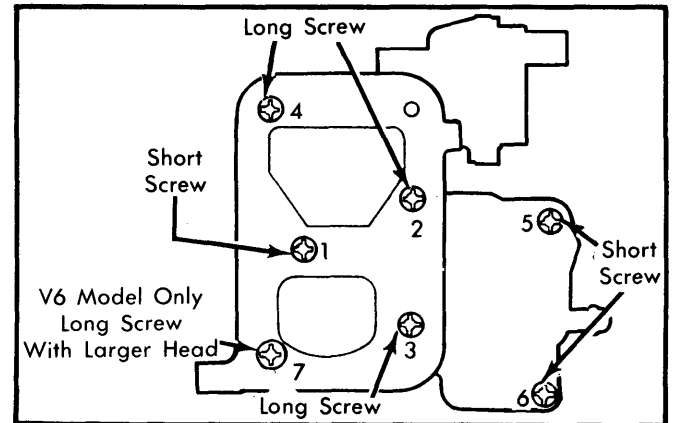

Fig. 15 Air Horn Screw Location and Tightening Sequence

CARBURETOR ADJUSTMENT SPECIFICATIONS										
Application	Float Level Setting	Accel. Pump Setting	Choke Coil Lever Setting	Choke Rod Setting	Air Valve Rod Setting	Vacuum Break		Auto. Choke Setting	Choke Unloader Setting	Secondary Lockout Setting
						Primary Setting	Secondary Setting			
American Motors										
2SE										
17081790	7/32"	1/2	.085"	25°	2°⊙	19°	TR	32°	.065"
17081791	7/32"	1/2	.085"	25°	2°⊙	19°	TR	32°	.065"
17081792	7/32"	1/2	.085"	25°	2°⊙	19°	TR	32°	.065"
17081793	7/32"	1/2	.085"	25°	2°⊙	19°	TR	32°	.065"
17081794	7/32"	1/2	.085"	25°	2°⊙	19°	TR	32°	.065"
17081795	7/32"	1/2	.085"	25°	2°⊙	19°	TR	32°	.065"
17081799	7/32"	1/2	.085"	25°	2°⊙	19°	TR	32°	.065"
E2SE										
17081796	7/32"	TR	.065"	25°	2°⊙	19°	TR	32°	.065"
17081797	7/32"	TR	.085"	25°	2°⊙	19°	TR	32°	.085"
General Motors										
E2SE										
17081650	1/4"	TR	.085"	17°	1°	25°	34°	TR	35°	.025"
17081651	1/4"	TR	.085"	17°	1°	29°	35°	TR	35°	.025"
17081652	1/4"	TR	.085"	17°	1°	25°	34°	TR	35°	.025"
17081653	1/4"	TR	.085"	17°	1°	29°	35°	TR	35°	.025"
17081656	1/4"	TR	.085"	17°	1°	30°	35°	TR	33°	.025"
17081657	1/4"	TR	.085"	17°	1°	29°	35°	TR	35°	.025"
17081658	1/4"	TR	.085"	17°	1°	30°	35°	TR	33°	.025"
17081659	1/4"	TR	.085"	17°	1°	29°	35°	TR	35°	.025"
17081670	5/32"	TR	.085"	18°	1°	19°	TR	32°	.025"
17081671	5/32"	TR	.085"	33.5°	1°	21°	TR	32°	.025"
17081672	5/32"	TR	.085"	18°	1°	19°	TR	32°	.025"
17081673	5/32"	TR	.085"	33.5°	1°	21°	TR	32°	.025"
17081740	1/4"	TR	.085"	17°	1°	25°	34°	TR	35°	.025"
17081742	1/4"	TR	.085"	17°	1°	25°	34°	TR	35°	.025"
17081746	1/4"	TR	.085"	17°	1°	30°	35°	TR	33°	.025"
17081747	1/4"	TR	.085"	17°	1°	29°	35°	TR	35°	.025"
17081748	1/4"	TR	.085"	17°	1°	30°	35°	TR	33°	.025"
17081749	1/4"	TR	.085"	17°	1°	29°	35°	TR	35°	.025"

TR — Tamper Resistant
 ⊙ — Maximum Degree Setting