

## MOTORCRAFT MODEL 2150 2-BARREL

### CARBURETOR APPLICATION

#### FORD MOTOR CO.

Application	Ford Part No. ①
4.2L (255") V8	
Federal .....	E1KE-CA, DA, EA, FA, GA, HA, RA, SA E1WE-EA, FA
5.0L (302") V8	
Federal .....	E1WE-CA, DA

① — Ford basic part number is 9510.

### CARBURETOR IDENTIFICATION

Carburetor can be identified by a tag attached to the air horn. This tag contains number and design change codes in addition to the build date. Always refer to the tag number when ordering or replacing parts.

### DESCRIPTION

Motorcraft 2150 carburetors are made up of 2 assemblies; the air horn and main body. Some models are equipped with an altitude compensating device. The air horn serves as the main body cover and contains choke plate and diaphragm assemblies, fuel bowl vents, hot idle compensator (if equipped) and the pullover enrichment system (if equipped). The main body contains throttle plates, fuel bowl, enrichment valve assembly and high speed bleed system. Automatic choke housing, throttle solenoid positioner (if equipped) and altitude compensator aneroid (if equipped) are attached to the main body.

Within each bore are main and booster venturi, main fuel and accelerator pump discharges, idle discharge and a throttle plate. High speed bleed openings with a mechanical bleed control are contained in the booster venturi. This provides more precise high speed operation and better low speed response. Most models use an all electric choke heater. Some are equipped with an exhaust heated choke in conjunction with an electric assist.

### ADJUSTMENT

#### HOT (SLOW) IDLE RPM

See appropriate article in TUNE-UP SERVICE PROCEDURES.

#### IDLE MIXTURE

See appropriate article in TUNE-UP SERVICE PROCEDURES.

#### COLD (FAST) IDLE RPM

See appropriate article in TUNE-UP SERVICE PROCEDURES.

#### ACCELERATOR PUMP STROKE

**NOTE** — Accelerator pump stroke has been preset at factory for each particular engine application. Additional holes are only provided for different engine applications.

1) On adjustment limiting carburetors, support area below pump housing roll pin to prevent damage to pump housing. Using blunt-tipped punch and small hammer, remove roll pin attaching pump link to pump housing.

2) Lift pump link and rod up and over carburetor until keyed end of rod is aligned with keyed hole in pump overtravel lever. Remove and reposition rod in specified hole and reassemble pump link and rod assembly.

**NOTE** — Adjustment limiting carburetors are identified by a new plastic tamper-proof retaining clip instead of metal retaining clip.

3) On all other carburetors, pry up on tab portion of metal retaining clip using small screwdriver and disengage rod assembly from overtravel lever.

4) Position clip in specified hole of overtravel lever and insert rod assembly through hole in clip and overtravel lever. Snap end of clip over rod assembly. See Fig. 1.

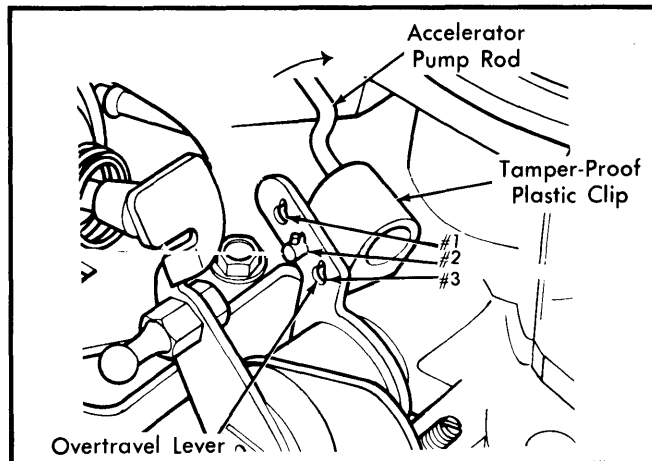

Fig. 1 Accelerator Pump Stroke

#### FLOAT LEVEL (DRY SETTING)

**NOTE** — Dry float setting is preliminary adjustment only. Final adjustment (wet setting) must be made after carburetor is installed on vehicle.

With air horn removed, depress float tab to seat fuel inlet needle. Measure distance from top of main body (gasket removed) to float, at point 1/8" from free end of toe. If adjustment is necessary, bend float tab.

**CAUTION** — Do not allow float tab to contact needle while making float adjustment as Viton needle tip may be damaged. See Fig. 2.

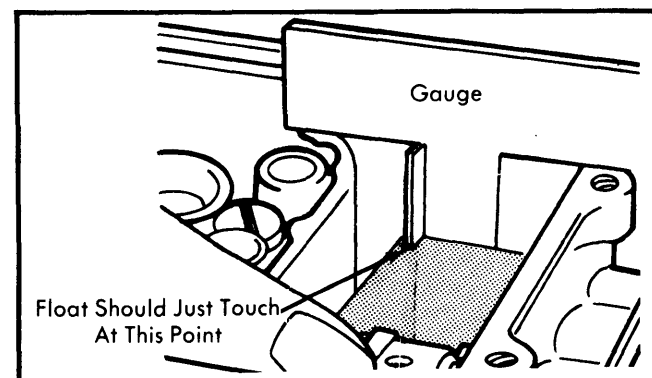

Fig. 2 Adjusting Float Level (Dry Setting)

#### FLOAT LEVEL (WET SETTING)

1) Warm up engine to operating temperature. Ensure vehicle is on flat, level surface. Stop engine and remove air cleaner and air horn attaching screws. Leave air horn in position on carburetor. Start engine. See Fig. 3.

## MOTORCRAFT MODEL 2150 2-BARREL (Cont.)

2) Allow engine to idle for a few minutes to stabilize fuel level. With engine idling, remove air horn and gasket.

3) Measure distance, with suitable "T" scale, from machined surface of main body to level of fuel in fuel bowl. Make measurement at least  $\frac{1}{4}$ " away from sides of bowl to be sure of accurate reading.

4) If level is not within specifications, adjustment is needed. Stop engine before adjusting to avoid fire danger from fuel spray. Bend float tab (contacting inlet valve) up to raise fuel level and down to lower level.

5) After each adjustment, install air horn with 2 screws, start engine and idle long enough for fuel level to adjust to new adjustment. Stop engine, recheck fuel level.

6) When correct level is obtained, install new air horn gasket; replace air horn (install I.D. tag). Be sure plastic dust seal on choke rod is positioned properly and does not bind rod.

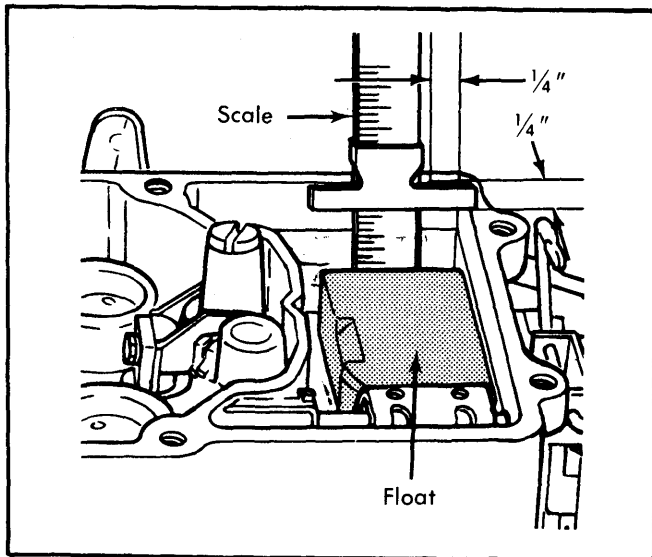

Fig. 3 Adjusting Float Level (Wet Setting)

## CHOKE VALVE PULL-DOWN

## (INITIAL CHOKE VALVE CLEARANCE)

1) Before making adjustment, perform steps 1) through 3) of Automatic Choke adjustment procedures. Then using edge of small half-round file, file groove  $\frac{1}{8}$ " deep and  $\frac{1}{4}$ " back from rear edge of pulldown motor. Insert awl in filed groove and angle tip of awl toward pulldown motor cover plug.

2) Using small hammer, tap awl gently to remove plug. Apply outside vacuum source to choke vacuum diaphragm or manually force diaphragm to the retracted position. Apply heat to adjusting screw using soldering gun to heat up Loctite.

3) Turn screw back and forth several times to loosen up screw. When screw is loose, remove and clean off all Loctite. Reinstall screw. Measure choke pulldown specified clearance between lower edge of choke valve and air horn wall. See Fig. 4.

4) If clearance is not to specification, adjust by turning screw in end of choke pulldown motor. Turn adjusting screw clockwise to decrease clearance and counterclockwise to increase clearance. Apply Loctite (or equivalent) to base of screw to lock in place.

5) Install pulldown motor cover plug and tap gently into place using small hammer. Seal plug edge and groove in cover with epoxy sealer. When adjustment is completed, perform steps 4) and 5) of Automatic Choke adjustment procedure to complete this adjustment.

**NOTE** — Fast idle cam linkage must be checked and adjusted after choke valve pull-down adjustment. Do not adjust automatic choke until after fast idle cam is adjusted.

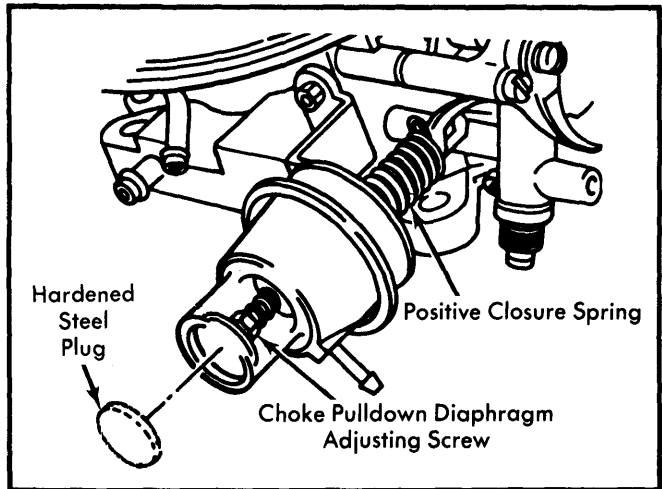

Fig. 4 Adjusting Choke Pull-Down Clearance

## FAST IDLE CAM LINKAGE

1) Before making adjustment, perform steps 1) through 3) of Automatic Choke adjustment procedure. Then open throttle and position fast idle speed screw on high step of fast idle cam.

2) Apply outside vacuum source to choke vacuum diaphragm or manually force diaphragm to the retracted position. Open throttle and check movement of fast idle cam. Fast idle speed screw should drop down to the kickdown step of cam and align with "V" notch on cam.

3) To adjust, turn fast idle cam lever adjustment screw. See Fig. 5. Reconnect vacuum hose to vacuum diaphragm if disconnected. When adjustment is completed, perform steps 4) and 5) of Automatic Choke adjustment procedure to complete this adjustment.

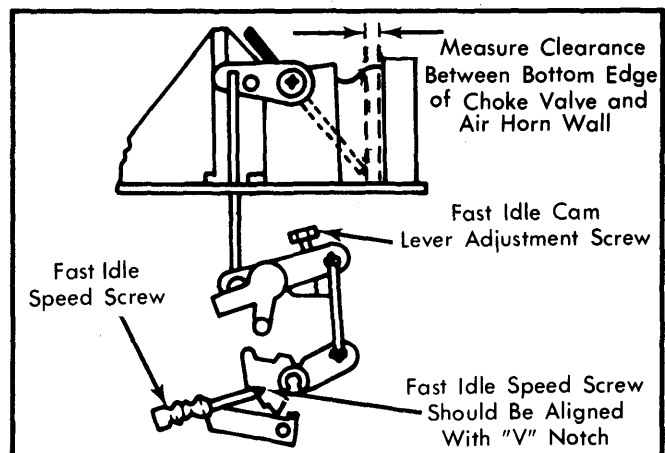

Fig. 5 Adjusting Fast Idle Cam Linkage

## MOTORCRAFT MODEL 2150 2-BARREL (Cont.)

### CHOKE UNLOADER

1) Hold throttle wide open. Measure specified choke unloader clearance between lower edge of choke valve and air horn wall. See Fig. 6.

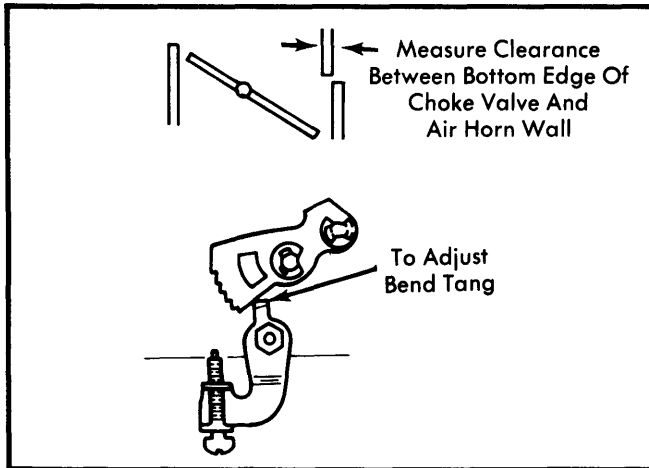

Fig. 6 Adjusting Choke Unloader

2) To adjust, bend choke unloader tang that contacts fast idle cam. Bend tang toward cam to increase clearance and away from cam to decrease clearance.

3) After adjustment is correct, open throttle until unloader tang is directly under fast idle cam pivot. Make sure there is .070" clearance between unloader tang and fast idle cam. See Fig. 7.

4) Operate throttle and make sure that tang does not stick or bind against any portion of the linkage or carburetor casting.

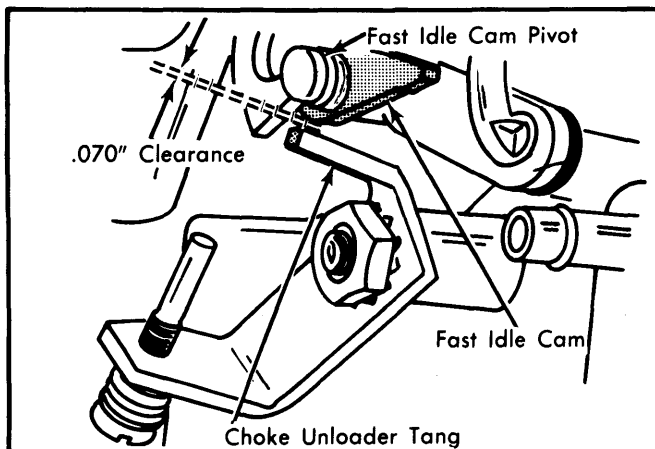

Fig. 7 Unloader-to-Fast Idle Cam Clearance

### AUTOMATIC CHOKE

1) Center punch choke cover retaining screw heads. Align a 1/4" drill on screw head and drill only enough to remove screw head. Repeat for remaining 2 screw heads. Remove choke cover by inserting sharp, flat chisel between choke cover gasket layers.

2) Remove remaining portion of retaining screws from choke housing using small pliers. Carefully clean epoxy and gasket from choke cover and housing using gasket scraper.

**NOTE** — Remove choke cover carefully. Choke cover and gasket are sealed to housing with epoxy sealer.

3) Install and retain choke cover using 3 screws. Rotate choke cover counterclockwise (rich) to lightly close choke valve. Turn cover an additional 1/4" turn counterclockwise and tighten retaining screws.

4) Remove 3 retaining screws and choke cover. Apply 1/2" bead of epoxy sealer to each side of choke cover gasket adjacent to the 3 screw bosses. Install gasket and choke cover using new breakaway screws.

5) Rotate cover assembly in "Rich" or "Lean" direction to align reference mark on choke cover with specified scale graduation on housing. Tighten each breakaway screw until head of screw breaks off.

**NOTE** — Ensure that bimetal spring tab is engaged in slotted choke shaft lever.

### SOLENOID BOWL VENT VALVE TEST

1) Remove air cleaner. Turn ignition "ON" and "OFF". A "click" should be heard and felt if the solenoid is operating properly.

2) If not, disconnect electrical lead. Connect a voltmeter. Turn ignition "ON". There should be 12 volts present at lead connector. If not, repair wiring as required.

3) If 12 volts are present at lead connector, check valve for binding and/or plugged condition. Repair as required. If valve is not binding and/or plugged, replace solenoid valve assembly. Reinstall air cleaner.

## OVERHAUL

### DISASSEMBLY

**Air Horn** — 1) Remove air cleaner anchor screw and automatic choke control rod retainer. Remove air horn attaching screws, lock washers, carburetor I.D. tag, then remove air horn and gasket. Remove choke control rod by loosening screw securing choke shaft lever to choke shaft. Remove rod from air horn and slide plastic dust seal out of air horn.

2) Remove choke diaphragm assembly, then if necessary to remove choke plate, remove staking marks on attaching screws and remove screws. Remove choke plate by sliding it out of the shaft from the top of the air horn, then remove shaft from air horn.

3) On models equipped with altitude compensator, the bypass choke plate is removed in same way as main choke plate. To remove shaft, remove link retainer and slide shaft out of air horn.

**Main Body** — 1) Pry float shaft retainer from fuel inlet seat with a screwdriver, then remove float, float shaft retainer and fuel inlet needle assembly. Remove retainer and float shaft from float lever.

2) Remove fuel inlet needle, seat, filter screen and main jets. Remove booster venturi screw, booster venturi, metering rod assembly and gasket. Remove filter screen from booster venturi screw. To disassemble metering rod assembly, remove lift spring retaining clip and spring. Do not remove metering rod hanger from lift rod.

# 1981 Motorcraft Carburetors

## MOTORCRAFT MODEL 2150 2-BARREL (Cont.)

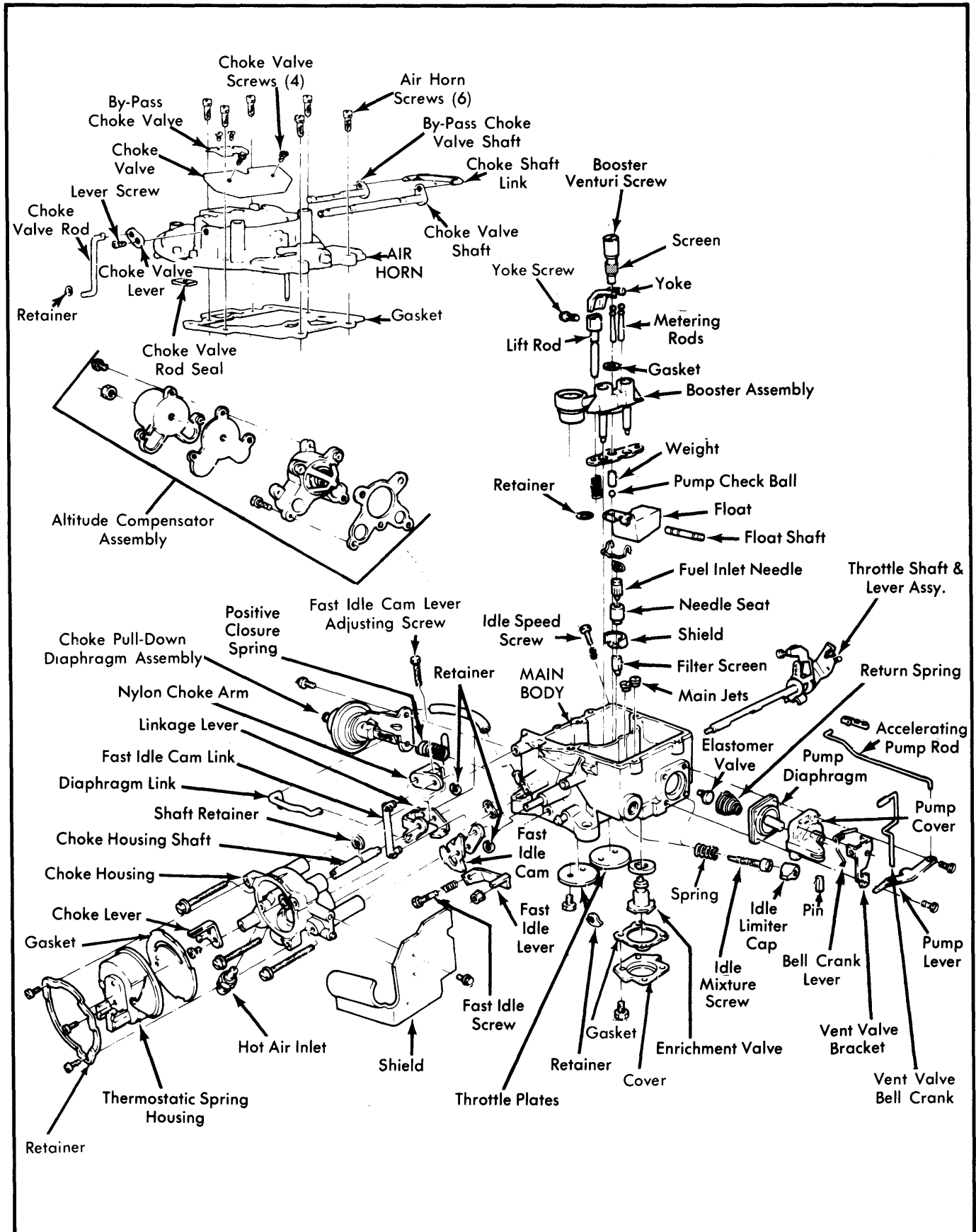

Fig. 8 Exploded View of Motorcraft Model 2150 Carburetor Assembly

## MOTORCRAFT MODEL 2150 2-BARREL (Cont.)

3) Invert main body and catch accelerator pump discharge weight and check ball. On adjustment limiting carburetors, remove roll pin attaching accelerator pump link to pump housing using blunt-tipped punch and small hammer. Remove pump link and rod assembly.

4) On all other carburetors, remove accelerator pump operating rod from overtravel lever and retainer by pressing ends of retainer together, while at same time, pressing rod away from retainer until free, then remove rod and retainer.

5) Remove accelerator pump cover screws. Remove bowl vent bell crank and bracket, accelerator pump cover, diaphragm assembly and spring. If necessary to remove Elastomer, grasp firmly and pull out.

**NOTE** — If tip of Elastomer valve broke off, make sure it is removed from fuel bowl. Elastomer valve must be replaced whenever it is removed.

6) Remove enrichment valve cover and gasket, then remove enrichment valve and valve gasket using box wrench. Remove mixture needle limiter caps, mixture needles and springs. Remove choke cover rivets, retainer, choke cover and gasket. Remove choke housing assembly retaining screws.

7) Remove choke housing assembly, gasket, fast idle cam rod and cam lever. Remove choke lever retaining screw and washer, then remove choke lever and fast idle cam lever. If necessary, remove nut and washer securing fast idle adjusting lever and remove lever.

8) Remove throttle solenoid positioner (if equipped). If removing throttle plates, mark each throttle plate with its corresponding bore for reassembly. Slide throttle shaft from main body. Mechanical high speed bleed actuator will drop out. It is located between throttle plates.

9) On altitude compensated carburetors, remove 4 attaching screws and remove aneroid and valve assembly with gasket from main body. Remove 3 aneroid-to-valve screws and separate aneroid, gasket and valve.

### CLEANING & INSPECTION

- Use a regular carburetor cleaning solution. Soak components long enough to thoroughly clean all surfaces and passages of foreign matter.
- Do not soak any components containing rubber, leather or plastic.
- Remove any residue after cleaning by rinsing components in a suitable solvent.
- Blow out all passages with dry compressed air.

### REASSEMBLY

**NOTE** — Use new gaskets and seals. Make sure that new gaskets fit correctly and that all holes and slots are punched through and correctly located. Replace Elastomer valve if removed from main body.

To reassemble carburetor, reverse disassembly procedure and note the following:

1) When installing new Elastomer check valve (if removed), lubricate tip of new valve and insert tip into center hole of accelerator pump cavity. Use needle nose pliers inserted in fuel bowl and pull valve in until it is fully seated. Cut off excess valve tip at retaining shoulder and remove tip from fuel bowl.

2) When installing idle mixture needles and springs, turn screws in with fingers until lightly seated. Then back screws off seated position 1½ turns for an initial adjustment. Do not install idle limiter caps until final adjustments have been made.

CARBURETOR ADJUSTMENT SPECIFICATIONS							
Application	Float Level		Accel. Pump Setting	Choke Pull-Down Setting	Fast Idle Cam Setting <sup>⓪</sup>	Choke Unloader Setting	Auto. Choke Setting <sup>⓪</sup>
	Dry Setting	Wet Setting					
<b>Ford Motor Co.</b>							
E1KE-CA	7/16"	13/16"	#3	.124"	"V" Notch	.250"	"V" Notch
E1KE-DA	7/16"	13/16"	#3	.124"	"V" Notch	.250"	"V" Notch
E1KE-EA	7/16"	13/16"	#3	.124"	"V" Notch	.250"	"V" Notch
E1KE-FA	7/16"	13/16"	#3	.124"	"V" Notch	.250"	"V" Notch
E1KE-GA	7/16"	13/16"	#3	.120"	"V" Notch	.250"	"V" Notch
E1KE-HA	7/16"	13/16"	#3	.120"	"V" Notch	.250"	"V" Notch
E1KE-RA	7/16"	13/16"	#3	.124"	"V" Notch	.250"	"V" Notch
E1KE-SA	7/16"	13/16"	#3	.124"	"V" Notch	.250"	"V" Notch
E1WE-CA	7/16"	13/16"	#2	.120"	"V" Notch	.250"	"V" Notch
E1WE-DA	7/16"	13/16"	#2	.120"	"V" Notch	.250"	"V" Notch
E1WE-EA	7/16"	13/16"	#2	.120"	"V" Notch	.250"	"V" Notch
E1WE-FA	7/16"	13/16"	#2	.120"	"V" Notch	.250"	"V" Notch

⓪ — "V" Notch is equal to kickdown setting. See adjustment procedure.