

1981 Holley Carburetors

HOLLEY MODEL 6145 SINGLE BARREL

CARBURETOR APPLICATION

Application	Chrysler Corp. Carb. No.	
	Man. Trans.	Auto. Trans.
3.7L (225") 6-Cylinder California	R-9695A	

CARBURETOR IDENTIFICATION

Part number is stamped in float bowl body or on tag attached to carburetor.

DESCRIPTION

The Holley model 6145 is an "Electronic Feedback" type carburetor. The carburetor basic design is that of the Holley model 1945 used on other Chrysler Corp. vehicles. The carburetor is designed to maintain an air/fuel ratio within specified limits to allow the catalytic converter to operate effectively.

The carburetor is controlled by the Spark Control Computer. A conventional fixed main metering jet is used, in parallel with a fuel metering orifice. The orifice is blocked or opened by a duty cycle solenoid. When the solenoid is energized, the orifice is blocked and the overall air/fuel mixture is leaned out. When the solenoid is de-energized, fuel flows through the orifice and the mixture is enriched.

Under normal operating conditions, the solenoid is operated 10 cycles per second. The amount of time it is open vs. the amount of time closed will determine the average fuel enrichment. This average is determined by an exhaust gas oxygen sensor, then controlled by the Spark Control Computer.

The duty cycle solenoid is located next to the air horn on top of the carburetor and can be removed by removing the mounting screws and disconnecting the electrical lead. No adjustment is possible.

ADJUSTMENT

HOT (SLOW) IDLE RPM

See appropriate article in TUNE-UP SERVICE PROCEDURES.

IDLE MIXTURE

See appropriate article in TUNE-UP SERVICE PROCEDURES.

COLD (FAST) IDLE RPM

See appropriate article in TUNE-UP SERVICE PROCEDURES.

NOTE - All other adjustments are the same as the Holley model 1945 1-Barrel carburetor. See the Holley Model 1945 and 1946 Single Barrel article in this section for all remaining Adjustments and for carburetor Overhaul.

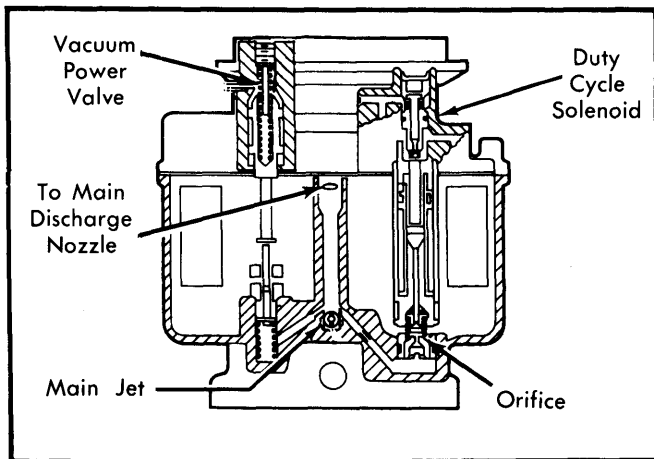

Fig. 1 Cutaway View of Main Metering System

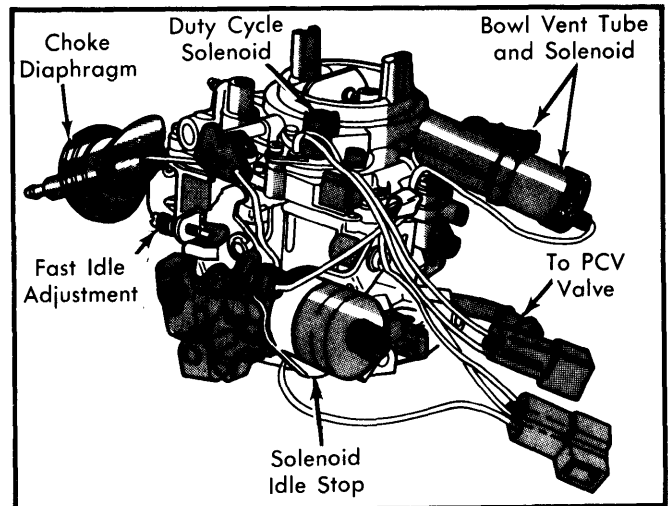

Fig. 2 Holley 6145 Carburetor Assembly

CARBURETOR ADJUSTMENT SPECIFICATIONS

Application	Float Level Setting	Accelerator Pump		Fast Idle Cam Setting	Choke Unloader Setting	Choke Vacuum Kick Setting	Auto. Choke Setting	Bowl Vent Setting
		Hole Setting	Stroke Setting					
R-9695A	Flush [ⓐ]	No. 2	1.615"	.090"	.250"	.150"	1/16"

[ⓐ] - See Adjustment procedure.