

## CARTER BBD 2-BARREL

### CARBURETOR APPLICATION

#### AMERICAN MOTORS

Application	AMC Carb. No.	
	Man. Trans.	Auto. Trans.
258" 6 Cyl.		
50 State .....	8303 .....	8302
Federal .....	8309 .....	
258" 6 Cyl. 4-WD		
Federal .....	8308 .....	
Calif. ....	8306 .....	8307
Altitude .....		8310

#### CHRYSLER CORP.

Application	Chrysler Corp. Carb. No.	
	Man. Trans.	Auto. Trans.
318" V8		
Federal .....		BBD-8291S

### CARBURETOR IDENTIFICATION

Carter carburetor number is stamped on a tag attached to carburetor by 1 air horn screw. See Fig. 1.

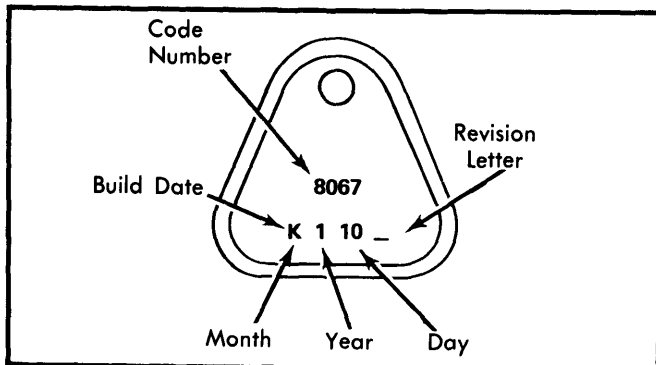

Fig. 1 Carter Model BBD Carburetor I.D. Tag

### DESCRIPTION

The model BBD carburetor is a 2 barrel downdraft type, incorporating 3 basic fuel metering systems. The idle system provides mixture for idle and low speed operation. The accelerator pump system provides additional fuel for acceleration. The main metering system provides a more economical mixture for normal driving.

Chrysler models are equipped with a duty cycle solenoid that is controlled by a Spark Control Computer. The solenoid is used to alter the main air/fuel mixture, in response to commands from an oxygen sensor. The solenoid alters both the low-speed (idle) and main metering systems by opening and closing an air bleed in each circuit.

When the solenoid is open, air flows through a passage in parallel with the normal circuit and leans out the mixture. When the passage is closed, the mixture is richened. The solenoid is operated 10 times a second by the computer and no adjustment is possible. Solenoid is located on rear of carburetor main body and secured by 2 screws.

American Motors models are equipped with an electronically controlled stepper motor which controls air flow through metered air bleeds located in each main fuel metering circuit. The stepper motor is activated through an on-board computer. Computer receives information from various sensors mounted on engine and in exhaust system. Computer then signals the stepper motor to retract metering rods from air bleeds (lean), or extend metering rods farther into air bleeds (rich).

### ADJUSTMENTS

#### HOT (SLOW) IDLE RPM

See appropriate article in TUNE-UP SERVICE PROCEDURES.

#### IDLE MIXTURE

See appropriate article in TUNE-UP SERVICE PROCEDURES.

#### COLD (FAST) IDLE RPM

See appropriate article in TUNE-UP SERVICE PROCEDURES.

#### FLOAT LEVEL

**American Motors - 1)** Remove air horn. Apply light pressure to float arm, gently seating needle in seat and raising float. See Fig. 2.

**2)** Place a straightedge across main body. Measure float level specified clearance between top edge of float and bottom of straightedge.

**3)** To adjust, bend float tang to obtain specified clearance. Float tang is portion of float that contacts end of float needle valve.

**CAUTION** - Do not adjust float while tang is resting against needle. Damage to synthetic tip of needle may occur.

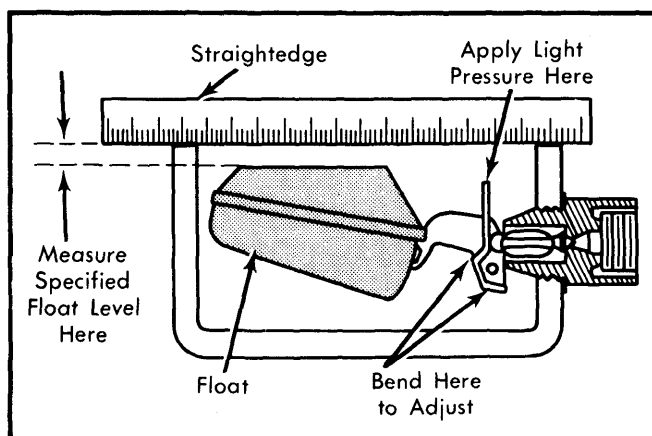

Fig. 2 Adjusting Float Level (American Motors)

**Chrysler Corp - 1)** Remove air horn. Turn main body upside down. Catch accelerator pump check ball as it falls out. Hold float pin retainer in with finger. Weight of float should be closing float needle. See Fig. 3.

**2)** Place a straightedge across main body. Measure float level specified clearance between straightedge and crown of each float.

## CARTER BBD 2-BARREL (Cont.)

3) To adjust, bend float tang to obtain specified clearance. Float tang is portion of float that contacts end of float needle valve.

**CAUTION** — Do not adjust while tang is resting against needle. Damage to synthetic tip of needle may occur.

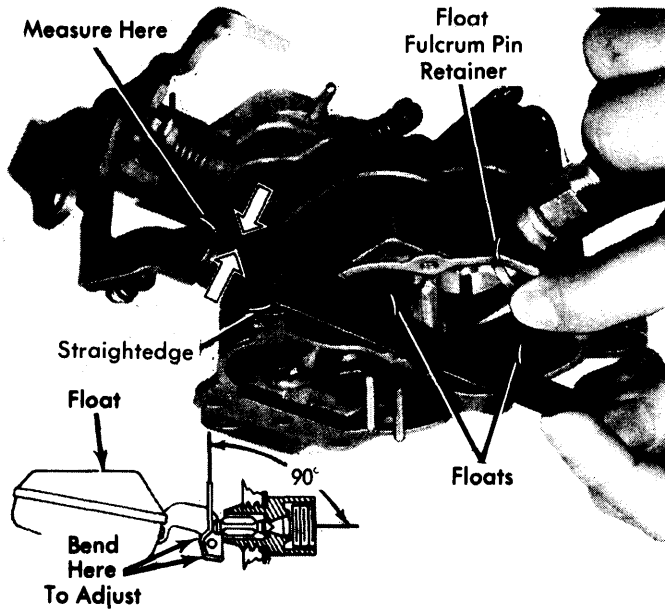

Fig. 3 Adjusting Float Level (Chrysler Corp.)

## VACUUM STEP-UP PISTON GAP QUALIFICATION

**NOTE** — This adjustment is required if step-up piston is removed or if piston lifter position is changed on actuating rod. This adjustment positions piston in a "mean" or centered position.

1) Remove step-up piston cover plate and gasket. Remove lifter lock screw and remove piston. See Fig. 4.

2) Measure piston gap as shown in illustration. If not to specification, adjust Allen head screw on top of piston.

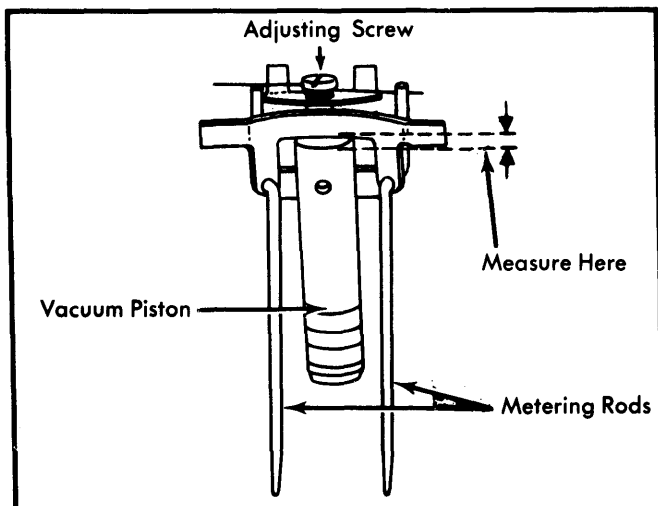

Fig. 4 Vacuum Step-Up Piston Gap Qualification

3) Turning screw clockwise makes mixture richer. Turning screw counterclockwise makes mixture leaner.

## VACUUM STEP-UP PISTON

**NOTE** — Perform Vacuum Step-Up Piston Gap Qualification adjustment first.

1) With vacuum piston installed, back off curb idle speed screw until throttle valves are seated. Count number of turns required to seat throttle valves.

2) Loosen lifter lock screw. Fully depress piston in bore. At same time, hold pressure against rod lifter tab. Tighten lifter lock screw.

3) Release lifter and piston. Adjust accelerator pump. Readjust curb idle speed screw to its original position.

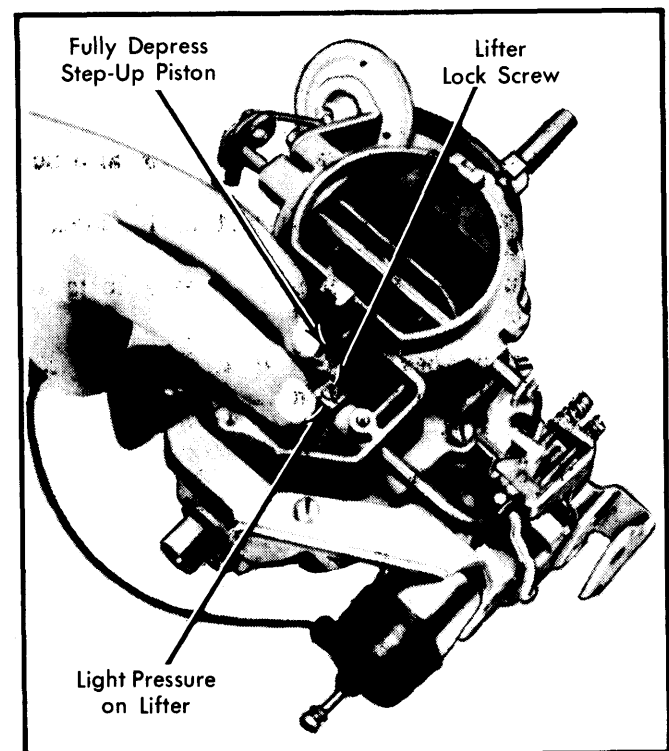

Fig. 5 Adjusting Step-Up Piston

## ACCELERATOR PUMP STROKE

1) Remove step-up piston cover plate and gasket. Back off curb idle speed screw until throttle valves are seated. Count number of turns required to seat throttle valves. Fast idle cam must be in open choke position. See Fig. 6.

2) Now turn curb idle screw clockwise until it just touches stop. Continue (2) more complete turns.

3) Some Chrysler Corp. models may have 2 holes in accelerator pump arm. If so, make sure accelerator pump "S" link is in outer hole.

## CARTER BBD 2-BARREL (Cont.)

4) Measure distance between surface of air horn and top of accelerator pump shaft. If adjustment is needed, loosen pump arm adjusting lock screw and turn sleeve to adjust pump travel. When correct measurement is obtained, tighten lock screw.

5) Install step-up piston cover plate and gasket. Readjust curb idle speed screw to its original position.

**NOTE** — On Chrysler Corp. models, if the accelerator pump adjustment is changed, the Bowl Vent Adjustment must be reset.

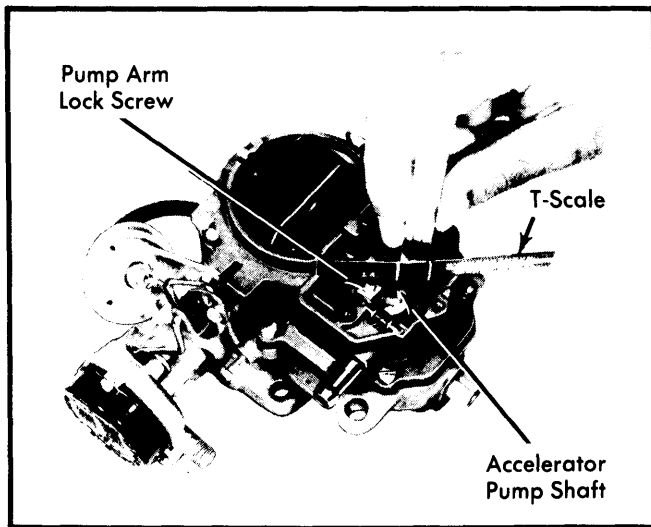

Fig. 6 Adjusting Accelerator Pump Stroke

### MECHANICAL BOWL VENT VALVE ADJUSTMENT

**NOTE** — This is not a precise adjustment. The purpose of this adjustment is to ensure that bowl vent is open at idle and closed at greater throttle openings. It may be performed on or off the vehicle.

**American Motors** — 1) Remove rollover check valve from air horn. Position throttle on high step of fast idle cam. Bowl vent should be closed.

2) Manually move fast idle cam until fast idle speed screw drops to 2nd step. Bowl vent should just start to open.

3) If bowl vent valve is not closed on high, 4th or 3rd steps of fast idle cam, bend tab of valve until it is closed.

4) If valve is not starting to open on 2nd step of cam, bend tab of valve until it just lifts off seat.

**NOTE** — Chrysler Corp. models are equipped with a bowl vent solenoid which allows float bowl vapors to flow to carbon canister only when engine is stopped. There is no vent adjustment necessary on these models.

### FAST IDLE CAM POSITION

**NOTE** — American Motors models use tamper-proof screws to retain choke coil cover. Grind screw heads until cover retaining ring can be removed and then remove remaining portion of cover screws from choke housing.

1) On American Motors models, remove choke coil cover retaining screws. Rotate choke coil cover 90° in the "Rich" direction. Install and tighten 1 slot-type retaining screw. On all models, place fast idle speed screw on 2nd step of fast idle cam. See Fig. 7.

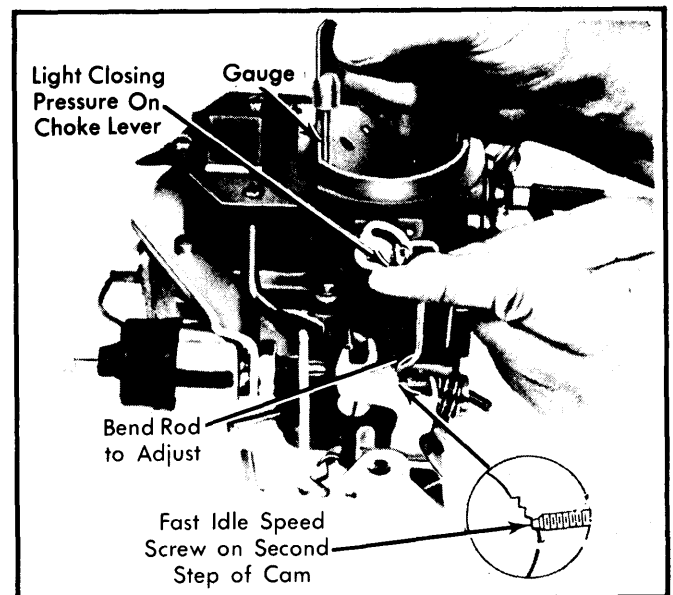

Fig. 7 Adjusting Fast Idle Cam Position

2) Hold choke valve toward closed position. Measure fast idle cam specified clearance between upper edge of choke valve and air horn wall.

3) If clearance is not to specification, adjust by bending fast idle cam rod. Bend rod down to increase clearance and up to decrease clearance. On American Motors models, readjust automatic choke and install new tamper-proof choke coil cover screws.

### CHOKE VACUUM BREAK (INITIAL CHOKE VALVE CLEARANCE)

1) On American Motors models, remove choke coil cover retaining screws. Rotate choke coil cover 90° in the "Rich" direction. Install and tighten 1 slot-type retaining screw. On all models, place fast idle speed screw on 2nd step of fast idle cam. See Fig. 8.

2) Apply an outside vacuum source of at least 19 in. Hg to choke vacuum break diaphragm. Apply enough closing force on choke valve to compress spring on diaphragm stem.

## CARTER BBD 2-BARREL (Cont.)

3) Measure choke vacuum break specified clearance between upper edge of choke valve and air horn wall. To adjust, bend vacuum break diaphragm rod. On American Motors models, readjust automatic choke and install new tamper-proof choke coil cover screws.

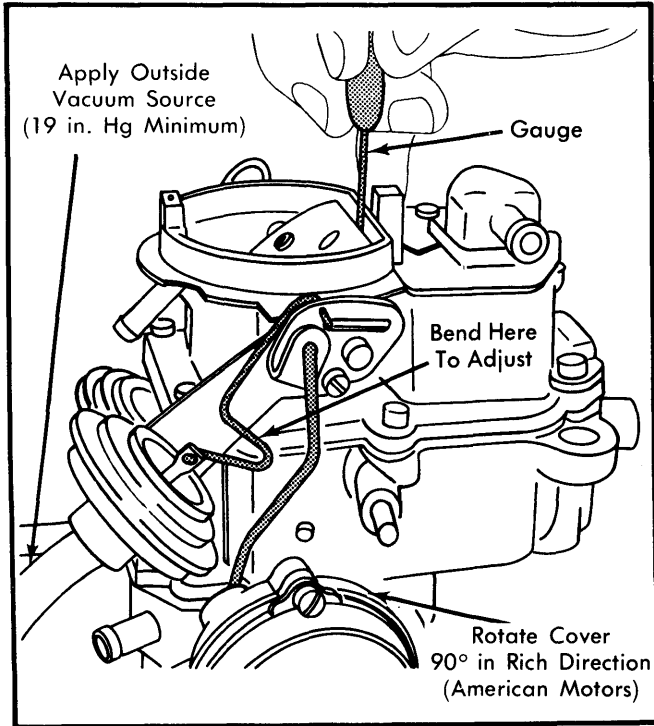

Fig. 8 Adjusting Choke Vacuum Break (Initial Choke Valve Clearance)

## CHOKE UNLOADER

1) Open throttle valves wide open. Apply light closing pressure to choke valve. See Fig. 9.

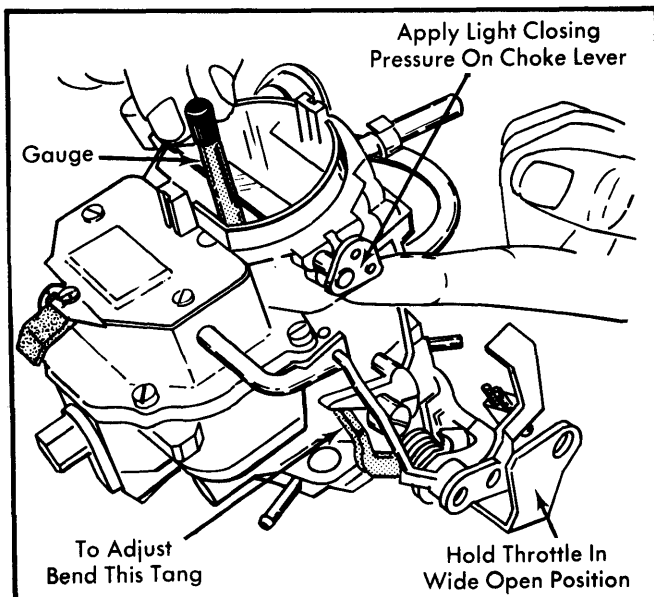

Fig. 9 Choke Unloader Adjustment

2) Measure specified choke unloader clearance between upper edge of choke valve and air horn wall.

3) To adjust, bend choke unloader tang. Make sure linkage is free and does not bind after making adjustment.

## AUTOMATIC CHOKE

**NOTE** — American Motors models use tamper-proof screws to retain choke coil cover. Grind screw heads until cover retaining ring can be removed and then remove remaining portion of cover screws from choke housing.

Automatic choke adjustment is made by removing choke housing retaining screws and turning housing to correct index or notch on choke housing. Refer to Specification Table for correct position for each carburetor.

## OVERHAUL

## DISASSEMBLY

**All Models** — 1) Place carburetor on stand and remove stepper motor or duty cycle solenoid. Remove retaining clip from accelerator pump arm link and remove link.

2) Remove cover plate from over step-up piston and remove gasket. Remove locks and screws from accelerator pump arm and vacuum piston rod lifter. Slide pump lever out of air horn.

3) Lift vacuum piston and step-up rods up and out of air horn as an assembly. Remove the vacuum piston spring. Remove choke vacuum diaphragm hose. Disconnect clips and remove link from choke housing lever and choke lever.

4) On American Motors models, rotate bowl vent assembly up out of bowl as far as possible and remove rubber valve seal.

5) Remove screw and lever from end of choke shaft. Remove choke vacuum break diaphragm. On American Motors models, remove automatic choke assembly. On all models, remove accelerator pump assembly.

6) Remove screws securing air horn and lift air horn up and away from main body. Discard gasket. Turn air horn upside-down and compress accelerator pump drive spring. Remove "S" link from pump shaft. Remove pump assembly.

7) Remove fuel inlet needle valve, seat and gasket from main body. Carefully lift out float fulcrum pin retainer and baffle. Lift out floats and fulcrum pin. Remove the main metering jets.

8) Remove venturi cluster screws. Lift cluster and gaskets away from main body and discard gaskets. DO NOT remove idle orifice tubes or main vent tubes from cluster as they can be cleaned with solvent and dried with compressed air while assembled.

9) Turn carburetor upside down and catch accelerator pump discharge and intake check balls as they fall out.

**NOTE** — Some American Motors models will not use a pump intake check ball in the pump cylinder. This fuel inlet passage will not be drilled. Cylinder will fill with fuel from top at cylinder slots. Pump plunger will use a floating type cup to prevent build up of fuel vapors in pump cylinder.

## CARTER BBD 2-BARREL (Cont.)

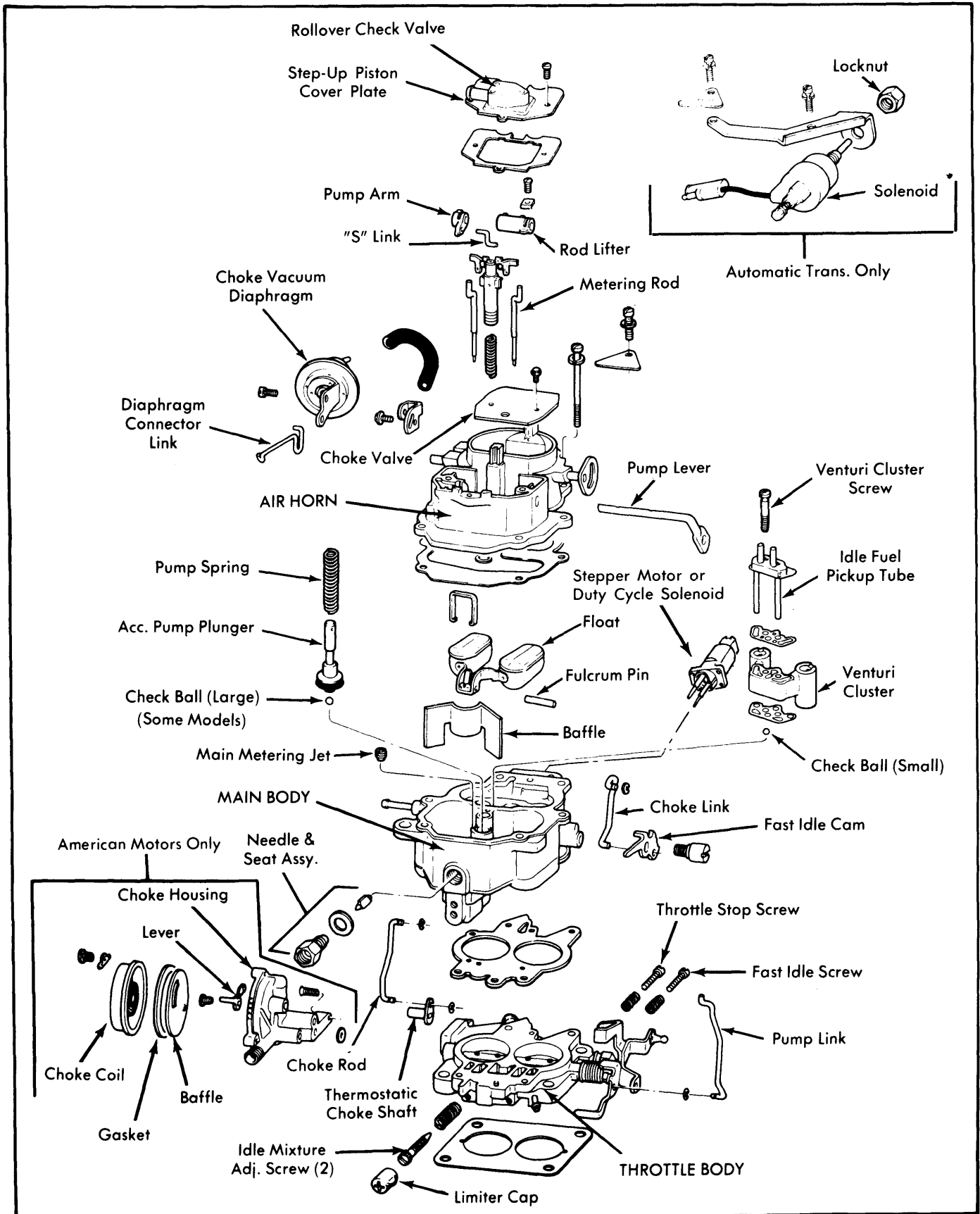

Fig. 10 Exploded View of Carter Model BBD 2-Barrel Carburetor

## CARTER BBD 2-BARREL (Cont.)

10) Turn idle limiter caps to stop. Remove plastic caps from idle mixture screws. Be sure to count number of turns it takes to seat screws for reassembly reference. Remove screws and springs.

11) Remove screws and separate throttle body from main body. Discard gasket. Check choke plate in air horn for freedom of movement. If any sticking or binding is evident, clean thoroughly.

## CLEANING &amp; INSPECTION

- Do not clean rubber, plastic parts or diaphragms, solenoid assemblies or pump plunger in solvent.
- Do not use wire, drill bit or hard parts to clean passages in carburetor.
- Inspect all parts for wear, cracks, nicks or burrs, uneven gasket sealing surfaces or warpage.
- Check for stripped threads, and excessive wear on throttle shafts. Replace throttle body assembly if shafts are worn.

## REASSEMBLY

**NOTE** — Use new gaskets and seals. Make sure new gaskets fit correctly and all holes are punched through and correctly located.

To reassemble carburetor, reverse disassembly procedures while noting the following:

**Idle Mixture Screw & Limiter Cap Installation** — 1) Install idle mixture screws and springs in throttle body. Tapered portion of screw must be straight and smooth. If tapered portion is grooved or ridged, use a new screw.

2) Turn each screw lightly against its seat with fingers. DO NOT use a screwdriver for installation. Back screws off seated position number of turns noted during disassembly and install plastic limiter caps with tab against stop.

**Accelerator Pump Assembly** — 1) Check operation as follows. Pour clean gasoline into carburetor bowl (1/2" deep). Operate pump plunger several times to fill cylinder and expel all air.

2) Using a small brass rod, hold discharge check ball down on its seat. Raise plunger and press downward. No fuel should be

emitted from either intake or discharge passage. If fuel does escape from passages, check if ball seat is damaged or dirty.

3) Clean check ball seat and retest. If leakage is still present, attempt to form a new ball seat. To form a new seat, install discharge check ball and place a piece of drill rod on top of check ball. Lightly tap drill rod with a mallet to form a new seat.

4) Remove and discard check ball and install a new one. Retest as previously described. If service does not correct problem, replace carburetor.

**Step-Up Piston & Rod Assembly** — Be sure step-up rods move freely each side of vertical position. Carefully guide step-up rods into main metering jets.

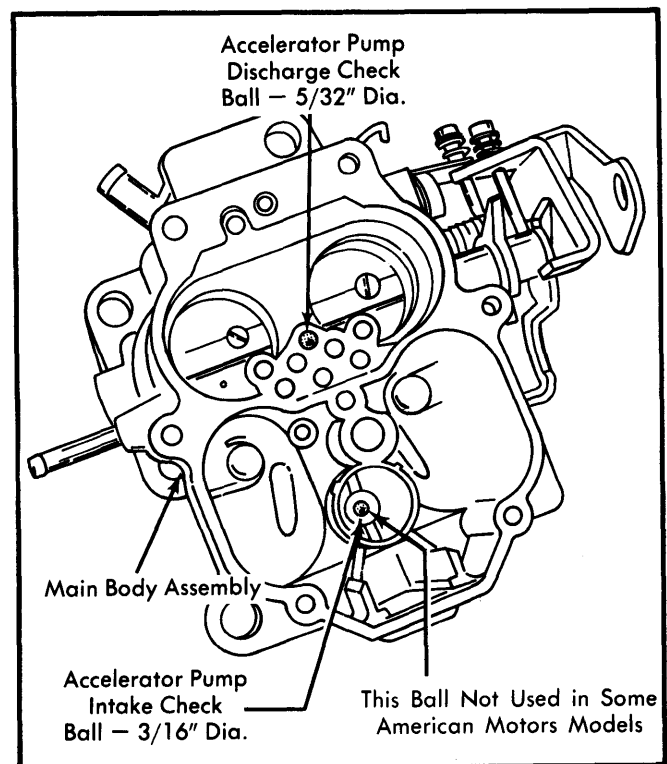

Fig. 11 View of Main Body Showing Locations of Large and Small Check Balls

## CARBURETOR ADJUSTMENT SPECIFICATIONS

Application	Float Level Setting	Vacuum Piston Gap Setting	Accel. Pump Stroke Setting	Fast Idle Cam Setting	Choke Vacuum Kick Setting	Choke Unloader Setting	Auto. Choke Setting
<b>American Motors</b>							
8302	.250"	.035"	.500"	.095"	.128"	.280"	1 Rich
8303	.250"	.035"	.500"	.090"	.128"	.280"	1 Rich
8306	.250"	.035"	.500"	.095"	.128"	.280"	1 Rich
8307	.250"	.035"	.500"	.095"	.128"	.280"	1 Rich
8308	.250"	.025"	.500"	.095"	.128"	.280"	2 Rich
8309	.250"	.035"	.520"	.093"	.128"	.280"	2 Rich
8310	.250"	.035"	.525"	.095"	.140"	.280"	Index
<b>Chrysler Corp.</b> BBD-8291S	.250"	.035"	.500"	.070"	.130"	.280"	.....