

TUNE-UP

ENGINE IDENTIFICATION

VEHICLE IDENTIFICATION NUMBER CODE

Engine can be identified by the Eighth Digit of Vehicle Identification Number, located on plate attached to top left corner of instrument panel and visible through windshield.

VIN Engine Codes

Application	Code
1.7L (105") 2-Bbl.	A
2.2L (135") 2-Bbl.	B
2.6L (156") 2-Bbl.	D

ENGINE IDENTIFICATION NUMBER CODE

The engine identification and serial number is stamped in the following locations: on 1.7L engines, above fuel pump on engine block; on 2.2L engines, rear of engine near distributor; on 2.6L engines, right front side on top of engine block.

TUNE-UP NOTES

NOTE — In order to comply with emission standards, specifications shown on engine compartment emission control tune-up decal must be used in all instances.

CAUTION — When performing tune-up on vehicles equipped with catalytic converters, do not allow or create a condition of engine misfire in more than one cylinder for an extended period of time. Damage to converter may occur due to loading converter with unburned air/fuel mixture.

CAUTION — On vehicles equipped with catalytic converters, do not add fuel system cleaning agents to fuel tank or carburetor as their use may be detrimental to the catalytic converter.

CAUTION — Before making a compression test or cranking engine using a remote starting switch, disconnect coil wire from distributor and secure to a good ground.

ENGINE COMPRESSION

Compression Ratio	
1.7L	8.2:1
2.2L	8.5:1
2.6L	8.2:1
Recommended Fuel 87 AKI Minimum Unleaded	
Compression Pressure	
1.7L & 2.2L	100 psi
2.6L	150 psi
Maximum Variation Between Cylinders	
1.7L & 2.2L	25 psi
2.6L	15 psi

Check compression pressure with engine warm, spark plugs removed, throttle valve wide open, and at cranking speed.

VALVE CLEARANCE

Application	Intake (Hot)	Exhaust (Hot)
1.7L008-.012"	.016-.020"
2.2L	Hydraulic	Hydraulic
2.6L	⓪.006"	.010"

⓪ — Jet Valve — .006".

VALVE ARRANGEMENT

1.7L	E-I-E-I-I-E-I-E
2.2L	E-I-E-I-E-I-E-I (Front to Rear)
2.6L	Right Side — All Exhaust Left Side — All Intake

SPARK PLUGS

Application	Gap (In.)	Torque (Ft. Lbs.)
1.7L048	20
2.2L035	20
2.6L041	20

Spark Plug Type

Application	Mopar Part No.
1.7L	65PR4
2.2L & 2.6L	65PR

HIGH TENSION WIRE RESISTANCE

Remove high tension wire from plug and remove distributor cap. Measure resistance between cap terminal and spark plug end. Use same procedure for coil wire. If resistance is too high, remove wire from cap (released from inside) and remeasure. If resistance is okay, clean cap connections. If not, replace wiring.

Resistance (Ohms)

Application	Maximum
1.7L & 2.2L	
Coil Wire	
Installed	25,000
Removed	15,000
Spark Plug Wire	
2.6L	50,000
2.6L	22,000

DISTRIBUTOR

All models are equipped with electronic ignition and no adjustments are necessary.

NOTE — Dwell is not adjustable, even though it may be read with a dwell meter. There is no means provided to change dwell.

TUNE-UP (Cont.)

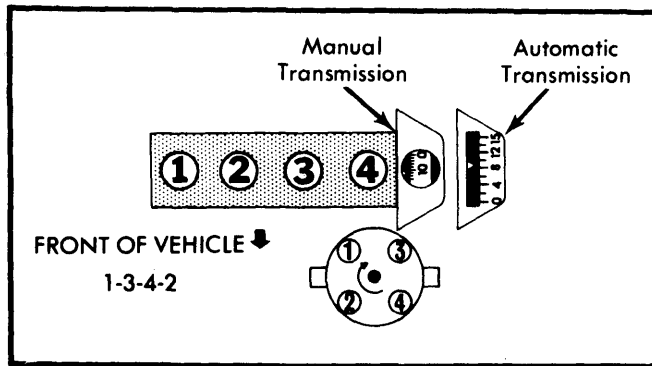

Fig. 1 Firing Order & Timing Marks (1.7L & 2.2L Engines)

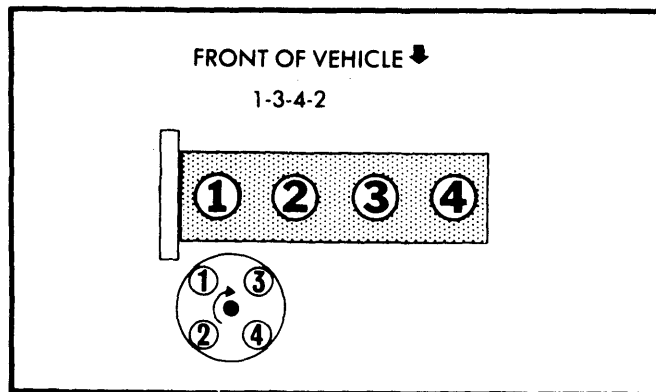

Fig. 2 Firing Order & Timing Marks (2.6L Engine)

IGNITION TIMING

CAUTION — Timing light connections should be made using proper adapters. Do not puncture cables, boots or nipples with test probes.

Connect a suitable timing light to number 1 cylinder. With engine at normal operating temperature, adjust to specified curb idle RPM. Disconnect and plug vacuum hose at vacuum transducer. Check timing through access hole in clutch housing.

Ignition Timing Specifications (Degrees BTDC@Idle)

Application	Timing
1.7L	
Federal Man. Trans.	12
All Other Models	10
2.2L	10
2.6L	7

HOT (SLOW) IDLE RPM

1.7L & 2.2L ONLY

1) Set parking brake, turn lights and accessories off, and connect tachometer to engine. Start and allow engine to reach normal operating temperature.

2) Return engine to idle. On models with fuel control computer, connect a jumper wire from carburetor switch to ground. Dis-

connect and plug vacuum lines at EGR valve. Connect a jumper wire at radiator fan so it runs continuously. Disconnect PCV valve from rubber connector and allow it to draw air. Plug 3/16" hose at canister.

3) On models with A/C, turn A/C on and open throttle slightly so solenoid can extend. Remove adjusting screw and spring from top of solenoid. Insert 1/8" Allen wrench into solenoid and adjust solenoid RPM. Automatic transmission selector should be in "D".

NOTE — Be sure compressor clutch is operating while solenoid RPM adjustment is made.

4) Return engine to idle and turn A/C off. Wait at least 1 minute, then check idle RPM. Turn screw on top of solenoid to adjust idle.

2.6L ONLY

1) Warm engine to operating temperature. Connect tachometer and place transmission selector in "N". Electric cooling fan should be off.

2) Wait 1 minute and check idle RPM. To adjust, turn idle speed adjusting screw (through access hole in choke cover plate). See Fig. 3.

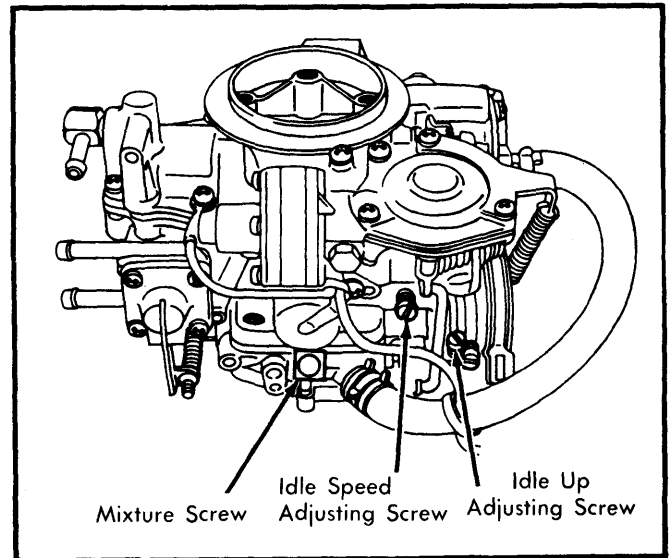

Fig. 3 Carburetor Adjustment Screw Locations (2.6L Engine — Shown With Choke Cover Removed)

3) Turn A/C on. With compressor running, adjust idle speed with idle up adjusting screw.

Idle Speed (RPM)

Application	Curb Idle	A/C Solenoid Idle
1.7L & 2.2L		
Man. Trans.	900	⓪850
Auto. Trans.	900	⓪750
2.6L	800	900

⓪ — If not equipped with A/C, set to 700.

TUNE-UP (Cont.)

IDLE MIXTURE

MIXTURE SCREW PLUG REMOVAL (1.7L & 2.2L ONLY)

1) Remove carburetor and clamp in vise with padded jaws so idle mixture screw is facing up. Drill 1/16" pilot hole through gasket surface at 45° angle into area of plug. Redrill hole to 1/8".

2) Drive mixture screw plug out with punch. Insert sharp punch through mixture screw hole and slide roll pin out. Reinstall carburetor.

PROPANE ENRICHMENT PROCEDURE (1.7L & 2.2L ONLY)

1) Start engine and warm to operating temperature. Turn off all accessories and place transmission selector in "N". Disconnect and plug hose at EGR valve.

2) Disconnect and plug vacuum hose to heated air door sensor at the 3-way connector. Connect propane supply hose in its place. Check engine timing and adjust if necessary.

3) Connect a jumper wire between carburetor switch and ground, then jumper radiator fan connector so it runs constantly. Disconnect and plug 3/16" control hose at canister. Remove PCV valve from rubber connector and allow it to draw air.

4) Open propane slowly until maximum RPM is reached. Adjust idle speed screw on top of solenoid to obtain propane RPM. Recheck propane flow and reset propane RPM if necessary.

5) Turn off propane and allow idle speed to stabilize. With air cleaner installed, adjust mixture screw carefully until curb idle speed is obtained. Pause between adjustments to allow idle to stabilize.

6) Turn on propane and observe maximum RPM. If more than 25 RPM from propane speed, repeat adjustment procedure.

7) Turn engine off and remove all test equipment. Reconnect hoses and wiring to original locations, then remove carburetor and install new roll pin and plug.

Propane Enrichment RPM (1.7L & 2.2L Only)

Application	Man. Trans.	Auto. Trans.
1.7L	1000	1000
2.2L	975	975

MIXTURE SCREW PLUG REMOVAL (2.6L ONLY)

Remove carburetor from engine. Hold in fixture or padded vise and drill out mixture screw plug. Use small punch to drive out roll pin. Install carburetor, using new flange gasket, but remove cover shield on front of carburetor.

IDLE MIXTURE ADJUSTMENT (2.6L ONLY)

1) Warm engine to operating temperature. Turn all accessories off and place transmission selector in "N". Check and adjust timing if necessary.

2) Disconnect and plug air hose between pulse air feeder and air cleaner. Insert CO meter probe into tailpipe of vehicle.

3) Set idle CO% and engine speed by simultaneously turning speed adjusting screw and mixture screw.

4) Connect air hose to air cleaner. If necessary, adjust curb idle to specifications by turning speed adjusting screw. Install new roll pin and mixture plug, then replace cover shield.

Idle Mixture CO Level (2.6L Only)

Application	CO%
2.6L	0.5

COLD (FAST) IDLE RPM

NOTE — No fast idle adjustment is necessary on 2.6L engines.

1.7L & 2.2L

1) With engine at normal operating temperature, transmission selector in "N", and all accessories off, ground carburetor switch. Check ignition timing. On 2.2L with automatic transmission, disconnect green wire from duty cycle solenoid on carburetor.

2) Remove air cleaner if necessary. Disconnect and plug EGR hose at EGR valve. Connect a jumper wire to radiator fan so it will run continuously.

3) Start engine and let speed stabilize. Place fast idle screw on 3rd step of fast idle cam (next to slowest). Adjust fast idle with fast idle speed screw.

4) Turn engine off and remove jumper wire to cooling fan. Reconnect EGR valve hose and green wire to solenoid.

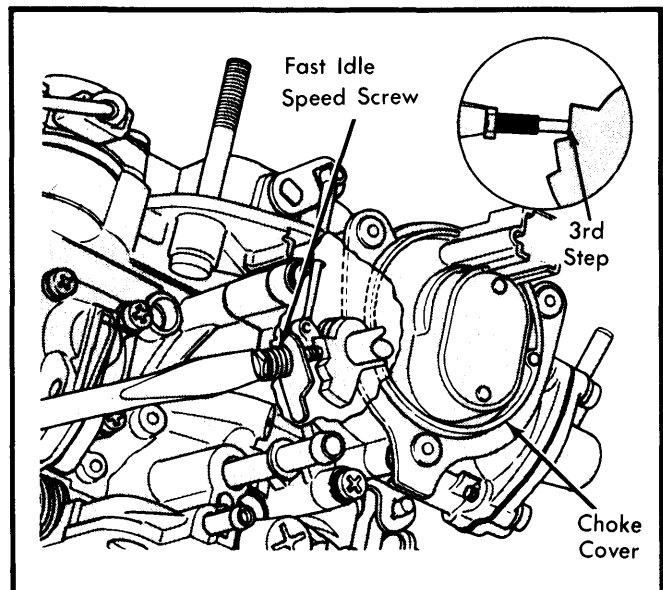

**Fig. 4 Fast Idle Speed Adjustment
(1.7L & 2.2L Engines Only)**

TUNE-UP (Cont.)

Fast Idle Speed (RPM)

Application	Man. Trans.	Auto. Trans.
1.7L	1400	1400
2.2L		
Fed.	1100	1500
Calif.	1200	1600

FUEL PUMP

Pressure (At Idle)	4.5-6.0 psi
Volume (At Idle)	1 pint in 30 seconds

AUTOMATIC CHOKE

All models are equipped with non-adjustable choke covers.

EXHAUST EMISSION SYSTEMS

See EXHAUST EMISSION SYSTEMS section.

GENERAL SERVICING

IGNITION

DISTRIBUTOR

Chrysler Electronic Ignition System is used on all 2.6L engines. 1.7L & 2.2L engines use the Electronic Spark Control system with electronic fuel control.

IGNITION COIL

Coil Resistance (Ohms@75°F)

Application	Primary	Secondary
Mitsubishi	0.7-0.85	9000-11,000
Prestolite	1.60-1.79	9000-11,700
Essex	1.41-1.62	9400-11,700

CARBURETION

CARBURETORS

Application	Model
1.7L & 2.2L	Holley 6520
2.6L	Mikuni

Other Data & Specifications — See *Tune-Up and Holley or Chrysler (Mikuni) Carburetors in FUEL SYSTEMS Section.*

ELECTRICAL

BATTERY

Application	Cranking Amps@0°F	Reserve Capacity Minutes
1.7L & 2.2L	310	60
2.6L	325	68
Optional		
Omni & Horizon	430	100
Aries & Reliant	500	120

STARTER

1.7L & 2.2L engines use either a Bosch or Nippondenso direct drive starter. A Nippondenso reduction gear starter is used on 2.6L engines.

Starter Specifications

Application	Volts	Amps	Test RPM
1.7L & 2.2L	11	47	6600
2.6L	11	85	3700

ALTERNATOR

1.7L & 2.2L engines use Chrysler alternators. 2.6L engines use Mitsubishi alternators with integral regulator.

Application	Rated Amp. Output
1.7L & 2.2L	
Yellow Tag	60
Brown Tag	65
2.6L	75

ALTERNATOR REGULATOR

1.7L and 2.2L engines use Chrysler Electronic Voltage Regulators. 2.6L engines use a Mitsubishi regulator, integral with alternator.

Application	Operating Voltage Volts@80°F
Chrysler	13.9-14.6
Mitsubishi	14.1-14.7

BELT ADJUSTMENTS

Tension (Lbs.) Using Strand Tension Gauge

Application	New Belt	① Used Belt
All	120	70

① — Any belt operated for 15 minutes.

1981 Chrysler Corp. 4 Tune-Up

GENERAL SERVICING (Cont.)

OIL & FUEL CAPACITIES

Application	Quantity
Crankcase	
1.7L & 2.2L (with or without filter)	4.0 qts.
2.6L (Including .5 qt. for filter)	5.0 qts.
Fuel Tank	
All Models	13.0 gals.

COOLING CAPACITIES

Application	Quantity
1.7L	6.0 qts.
2.2L	7.0 qts.
2.6L	8.5 qts.

REPLACEMENT INTERVALS

Component	Interval (Miles)
Oil Filter (Every 2nd oil change)	15,000
Air Filter	
1.7L & 2.2L	52,500
2.6L	30,000
PCV Filter (Clean & lubricate)	52,500
Spark Plugs	30,000

TRANSMISSION & DIFFERENTIAL CAPACITIES

Application	Quantity
Manual Transaxle	
A412 (SAE 80W-90 GL-4)	1.5 qts.
A460 (Dexron II)	2.0 qts.
Auto. Transaxle (Dexron II)	
Transmission	3.0 qts.
Differential	1.2 qts.