

FORD MOTOR CO. SPARK DELAY VALVES

DESCRIPTION

Spark Delay Valves (SDV) are used on many engine applications to permit closer control of vacuum-operated emission control equipment. All SDVs have internal sintered orifices to permit a restricted air flow in one direction, a check valve to allow free air flow in the other direction, and a filtering device to keep dirt and moisture from the emission control equipment.

NOTE — For location and names of various SDVs, refer to appropriate "Ford Motor Co. Vacuum Diagram" in this section.

OPERATION

By slowing, or restricting, vacuum signals to their respective emission control devices, the SDVs help modulate and regulate the vacuum signal being applied. Since engine vacuum levels vary with engine operating modes, it is important to control the vacuum signal by some means. The SDVs aid in this control.

TROUBLE SHOOTING

If valve is defective or installed backwards, engine will idle roughly, ping, and increase fuel consumption. When blowing air through valve by mouth, air will appear to flow in one direction. This should not be misinterpreted as direction of vacuum flow.

NOTE — It is very important that Black or inlet side of Spark Delay Valve and By-Pass Check Valve be connected to vacuum line leading to carburetor.

TESTING

DELAY VALVE TIME TEST

- 1) Connect appropriate side of delay valve to an external vacuum source set at 10" Hg. See chart below.
- 2) Connect a 24" length of vacuum hose and vacuum gauge to the other side of the delay valve.
- 3) Apply vacuum, observe gauge and note time, in seconds, required to go from 0-8" Hg.

NOTE — A steady 10" Hg must be applied by external vacuum source during this test.

- 4) Compare time to appropriate time chart below. If delay valve tested does not come within time limits, replace valve and repeat test.

Delay Valve Testing Attachments

Valve Type	Vac. Source Side	Vac. Gauge Side
Vacuum	Black	Color
Retard	Color	White
Two-Way		
Vacuum Vent	I.D. No.	
Air Cleaner	Color	White

Delay Valve Time Specifications (in Seconds)

Application	Min. Delay	Max. Delay
Vacuum Delay Valve		
Black & Gray	0.6	1.6
Black & Brown	1.0	3.0
Black & White	2.7	9.3
Black & Yellow	4.5	13.2
Black & Blue	6.8	18.8
Black & Green	8.0	26.0
Black & Orange	11.6	38.0
Black & Red	14.0	47.2
Retard Delay Valve		
White & Red	14.0	47.2
White & Blue	8.0	26.0
Two-Way Delay Valve		
Brown	1.0	3.0
White	2.7	9.3
Yellow	4.5	13.2
Green	8.0	26.0
Red	14.0	47.2
Vacuum Vent Delay Valve		
I.D. No. 5	7	13.7
I.D. No. 20	16	36.8
I.D. No. 40	28	67.6
Air Cleaner Delay Valve		
White & Red	14.0	47.2
White & Green	8.0	26.0
White & Blue	8.0	26.0

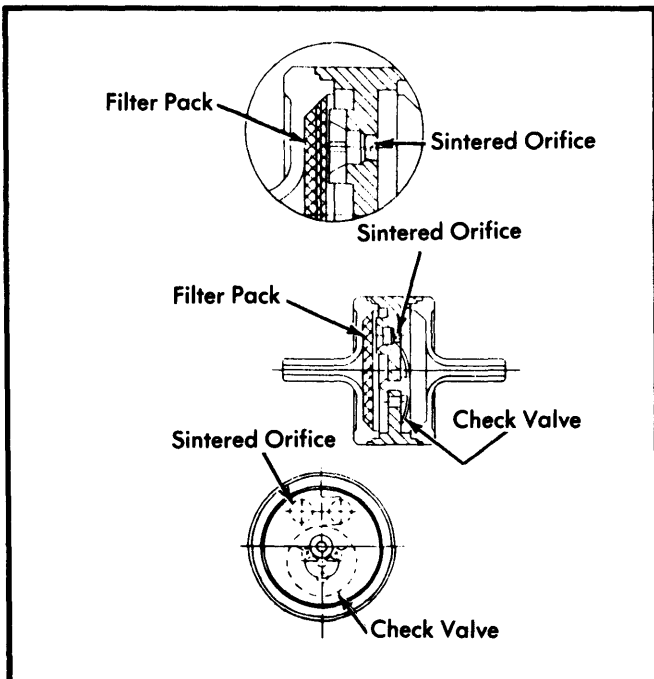

Fig. 1 Sectional Views of Typical Spark Delay Valve