

HOLLEY 4180-C 4-BARREL

CARBURETOR APPLICATION

FORD MOTOR CO.

Application	Ford Carb. No.	
	Man. Trans.	Auto. Trans.
460" V8 Federal	D9TE-BKA

CARBURETOR IDENTIFICATION

A carburetor identification tag is attached to carburetor. The tag contains part number prefix and suffix. Basic part number for all carburetors is 9510. A design change code (if any) is also stamped on the tag. An assembly date code (year, month and day) is also stamped on the tag.

DESCRIPTION

The Holley model 4180-C consists of 3 main components. The primary fuel bowl, secondary fuel bowl and main throttle body. Both primary and secondary fuel bowl assemblies are connected to the main fuel inlet system. All models are equipped with an automatic choke. Vehicles under 8500 lbs. GVW are equipped with an electric assist type choke. Vehicles over 8500 lbs. GVW utilize a hot air type automatic choke.

This model carburetor has a Modulated Power Valve System. This system ensures power valve opening when manifold vacuum increases (during full acceleration) beyond the point where power valve would start to close. Vacuum will bleed off whenever throttle valve opening is 50° or more.

All carburetors manufactured for federal models under 8500 lbs. GVW and all California models will be equipped with 2 external vent tubes.

ADJUSTMENT

HOT (SLOW) IDLE RPM

See appropriate article in TUNE-UP SERVICE PROCEDURES.

DECEL THROTTLE MODULATOR

See appropriate article in TUNE-UP SERVICE PROCEDURES.

IDLE MIXTURE

See appropriate article in TUNE-UP SERVICE PROCEDURES.

COLD (FAST) IDLE RPM

See appropriate article in TUNE-UP SERVICE PROCEDURES.

ACCELERATOR PUMP LEVER

1) Open throttle valves wide open. Using a feeler gauge, measure specified clearance between the lever adjustment screw head and pump arm with the pump arm manually open. See Fig. 1.

2) To adjust, loosen adjustment screw lock nut. Turn adjusting screw in to increase clearance and out to decrease clearance. Tighten lock nut.

NOTE — One-half turn of adjustment screw is equal to .015".

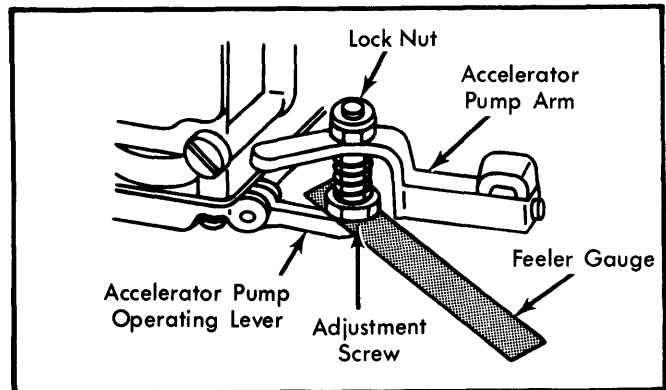

Fig. 1 Accelerator Pump Lever Adjustment

ACCELERATOR PUMP STROKE

NOTE — Accelerator pump stroke has been preset at factory. Setting should not be changed. If original setting has been changed, adjust as follows:

- 1) Check that plastic accelerator pump cam is aligned with correct hole (top or bottom) in throttle lever.
- 2) If not aligned with correct hole, remove screw. Reposition in correct hole. Install and tighten screw.

FLOAT LEVEL (DRY SETTING)

NOTE — Dry float setting is a preliminary adjustment only. Final adjustment (wet setting) must be made after carburetor is installed on vehicle.

- 1) Remove float bowl. Hold upside down. Float is adjusted correctly if top of float is parallel with float bowl. See Fig. 2.
- 2) To adjust, loosen lock nut and turn adjusting nut until float is parallel.

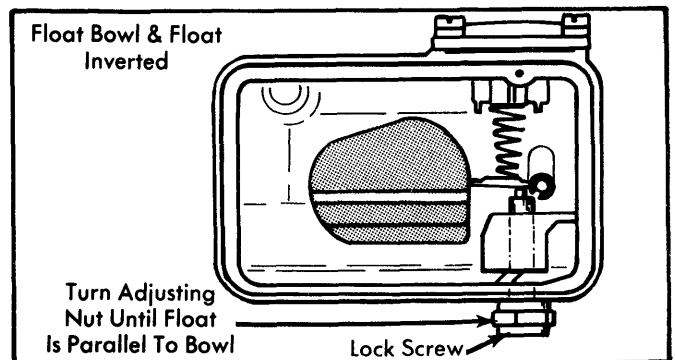

Fig. 2 Float Level Adjustment (Dry Setting)

FLOAT LEVEL (WET SETTING)

1) With engine at normal operating temperature, place vehicle on a flat, level surface. Remove air cleaner. Check fuel level at each float bowl separately. See Fig. 3.

HOLLEY 4180-C 4-BARREL (Cont.)

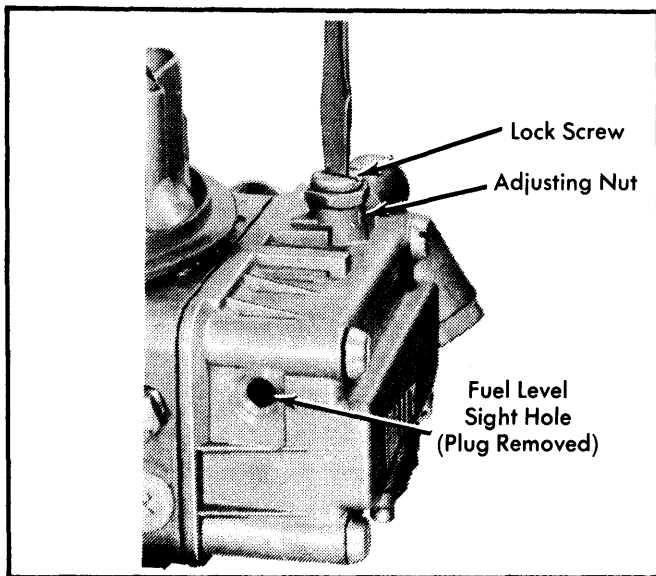

Fig. 3 Float Level Adjustment (Wet Setting)

2) Place a container under primary float bowl sight plug. With engine running remove plug and gasket. Fuel level should be at lower edge of plug opening.

3) If float level is too high, stop engine and drain fuel bowl by removing one of the lower float bowl screws. Drain fuel into a container. Tighten fuel bowl screw.

NOTE — Engine should be restarted to fill fuel bowl. This will make sure that foreign material did not cause a temporary flooding condition.

4) If float level is still too high, it should be lowered then raised to correct level. Remove both secondary and primary sight plugs and gaskets.

5) Loosen float adjustment lock screw on top of primary float bowl. Turn adjustment nut clockwise to lower fuel level below sight plug opening.

6) Now turn adjustment nut counterclockwise until fuel level just reaches lower edge of sight plug hole. Tighten lock screw. Allow fuel level to stabilize to check for correct level. Install sight plug and gasket.

7) If the float level was too low during original checking procedure, follow step 6).

SECONDARY THROTTLE VALVES

1) Hold secondary throttle valves closed. Turn secondary throttle valve stop screw out until secondary throttle valves seat in throttle bores.

2) Now turn screw in until screw just contacts secondary throttle valve lever.

CHOKE PULLDOWN

1) Remove choke thermostat housing, gasket and retainer. Insert a .026" wire gauge into choke piston bore. This moves piston down against stop screw. See Fig. 4.

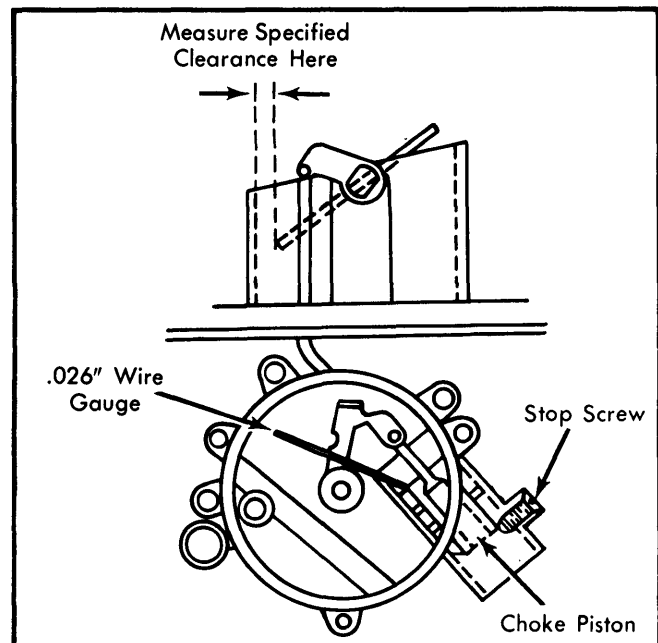

Fig. 4 Choke Pulldown Adjustment

2) Hold choke valve toward closed position. Measure specified choke pulldown clearance between lower edge of choke valve and air horn wall.

3) If adjustment is necessary, remove putty covering stop screw. Turn screw clockwise to increase clearance and counterclockwise to decrease clearance.

FAST IDLE CAM

1) Loosen choke thermostat housing screws. Rotate housing 45° counterclockwise (rich) to close choke valve. Tighten choke housing screws. See Fig. 5.

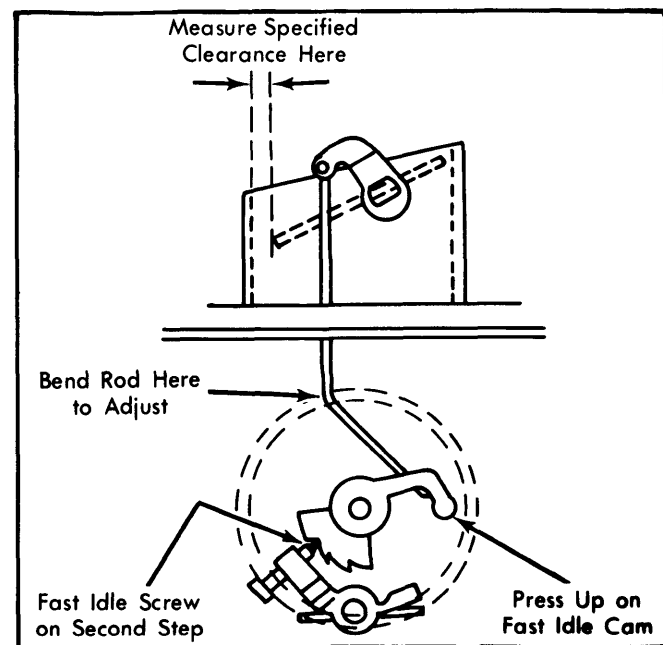

Fig. 5 Fast Idle Cam Adjustment

HOLLEY 4180-C 4-BARREL (Cont.)

- 2) Open then close throttle. This will position fast idle speed screw on top step of fast idle cam.
- 3) Insert a specified gauge between lower edge of choke valve and air horn wall. Open and close throttle and allow fast idle cam to drop.
- 4) Press up on fast idle cam. There should be little or no movement. This indicates that fast idle screw is on second (kickdown) step of cam, against first step.
- 5) To adjust, bend choke control rod until fast idle screw is in correct position on fast idle cam. Readjust automatic choke to correct setting and tighten screws.

CHOKE UNLOADER

- 1) Hold throttle valves wide open. Apply light closing pressure on choke valve. See Fig. 6.
- 2) Measure specified choke unloader clearance between lower edge of choke valve and air horn wall. To adjust, bend pawl on fast idle cam lever.

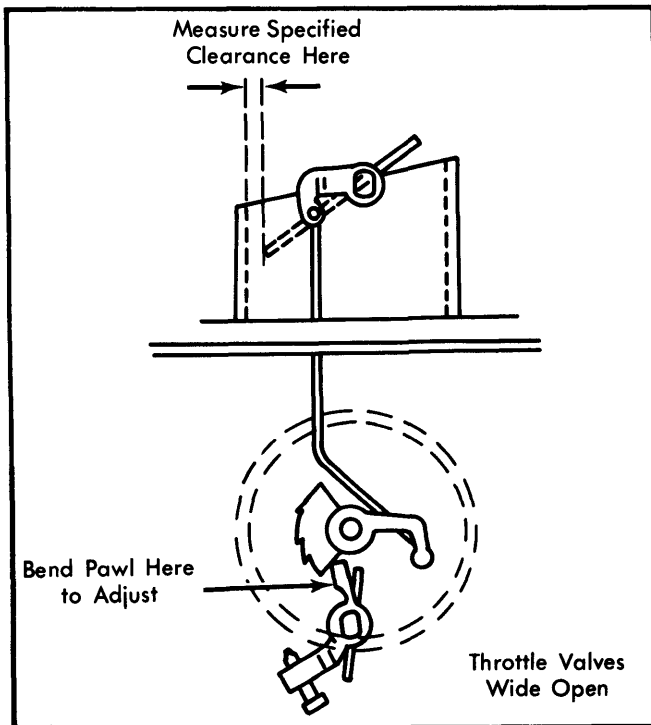

Fig. 6 Choke Unloader Adjustment

AUTOMATIC CHOKE

- 1) Loosen choke thermostat cover retaining screws.
- 2) Rotate cover assembly in "Rich" or "Lean" direction to align reference mark on cover with specified scale graduation in housing. Tighten cover screws.

OVERHAUL

DISASSEMBLY

Primary Fuel Bowl & Metering Block - 1) Remove primary fuel bowl and gasket. Remove metering block and gasket.

- 2) Remove pump transfer tube and "O" rings from main body if it was not removed with metering block.
- 3) Remove fuel line tube and "O" rings. Remove balance tube, washer and "O" ring seal.
- 4) Remove idle mixture screws and gaskets. Remove main jets and power valve from metering block.
- 5) Remove fuel level adjustment lock screw and gasket. Turn adjusting nut counterclockwise and remove nut and gasket.
- 6) Remove fuel inlet needle and seat assembly. Do not disassemble needle and seat, they are replaced as an assembly.
- 7) Remove float retainer using a pair of needle nose pliers. Slide float off shaft and remove spring from float.
- 8) Remove baffle plate from fuel bowl. Remove fuel level sight plug and gasket. Remove fuel inlet fitting, gasket and screen.
- 9) Invert fuel bowl. Remove accelerator pump cover, diaphragm and spring. Do not remove accelerator pump inlet check ball.

Secondary Fuel Bowl & Metering Block - 1) Remove fuel bowl. Using a clutch type screwdriver, remove metering block screws. Remove metering block, plate and gasket.

2) Remove balance tube, washer and "O" ring seal. Disassemble fuel bowl by following steps 5 through 8) in Primary Fuel Bowl assembly.

Main Body - 1) Remove air cleaner stud. Remove secondary diaphragm link retainer.

2) Invert carburetor. Remove throttle body screws and lock washers. Lift throttle body off main body and remove gasket.

3) Remove choke rod retainer from choke housing shaft and lever assembly. Remove choke cover, thermostatic spring and gasket. Remove choke main housing and gaskets.

4) Remove choke housing shaft nut, lock washer and spacer. Remove shaft and fast idle cam. Remove choke piston and lever assembly.

NOTE - If it is necessary to remove choke valve and shaft, tips of choke valve screws may have to be filed as they are staked into shaft.

5) If it is necessary, remove choke valve screws. Remove choke valve and slide out choke shaft.

6) Remove secondary diaphragm housing and gasket. Remove diaphragm housing cover, spring diaphragm and vacuum check ball.

NOTE - The secondary diaphragm housing must be removed before attempting to remove cover.

7) Remove accelerator pump discharge nozzle screw. Lift off discharge nozzle and gasket. Invert main body and catch accelerator pump discharge needle as it falls out of bore in main body.

1980 Holley Carburetors

HOLLEY 4180-C 4-BARREL (Cont.)

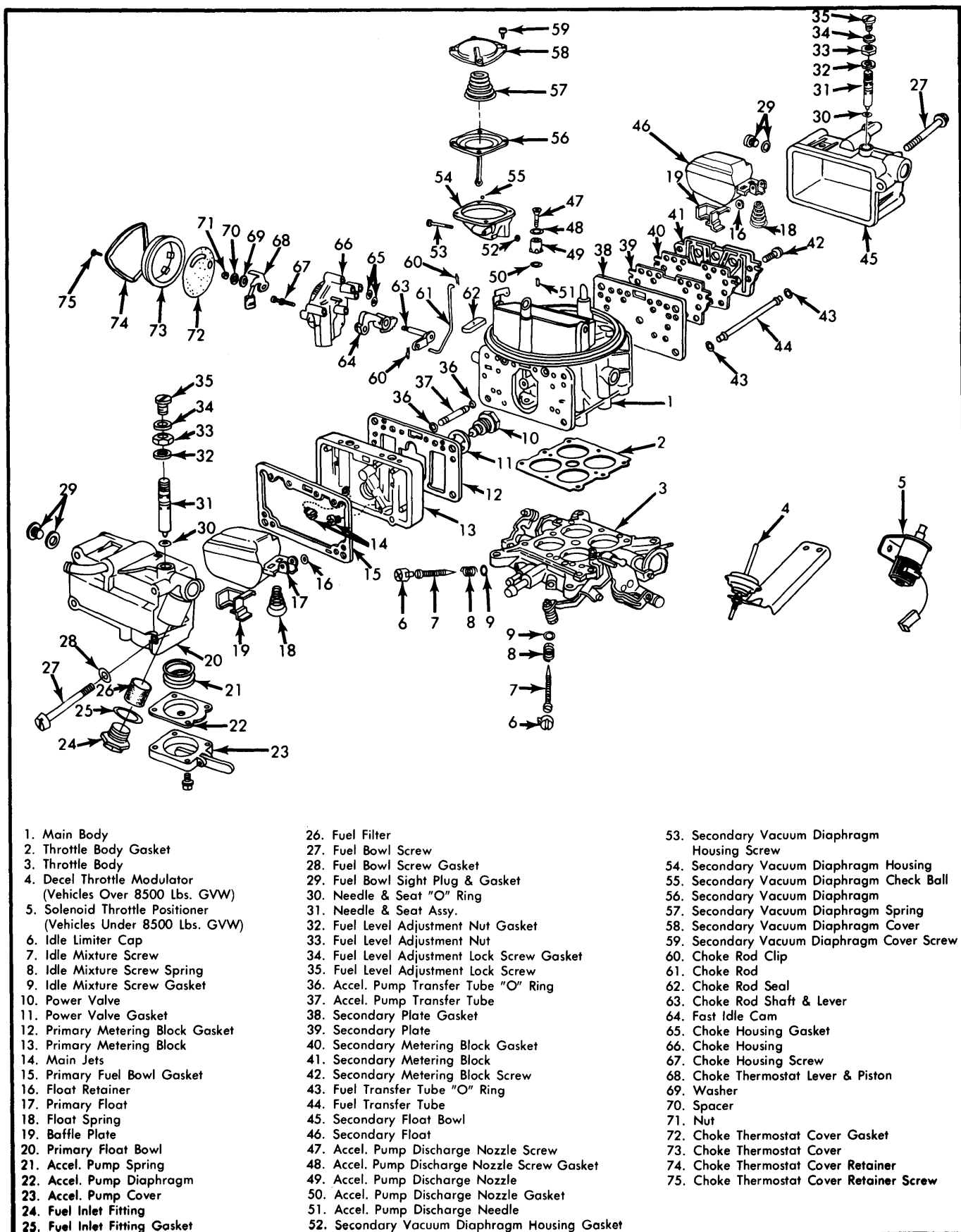

Fig. 7 Exploded View of Holley Model 4180-C 4-Barrel Carburetor

HOLLEY 4180-C 4-BARREL (Cont.)

Throttle Body — Components of throttle body are matched to meet emission control standards. Manufacturer does not recommend disassembly of throttle body.

CLEANING & INSPECTION

- Use a regular carburetor cleaning solution. Soak components long enough to thoroughly clean all surfaces and passages of foreign matter.
- Do not soak any components containing rubber, leather or plastic.
- Remove any residue after cleaning by rinsing components in a suitable solvent.
- Blow out all passages with dry compressed air.

REASSEMBLY

NOTE — Use new gaskets and seals. Make sure that new gaskets fit correctly and that all holes and slots are punched through and correctly located.

To reassemble carburetor, reverse disassembly procedure and note the following:

- 1) Apply petroleum jelly to all "O" rings before installation.
- 2) Make sure projection on the choke rod is positioned under the fast idle cam. This will ensure that fast idle cam will be raised up when the choke valve closes.
- 3) It will be necessary to install the secondary diaphragm housing cover and all 4 screws before diaphragm housing is installed onto main body.
- 4) When installing secondary metering block to main body, adjust balance tube so that it extends 1" from metering body.

CARBURETOR ADJUSTMENT SPECIFICATIONS						
Carb. No.	Accelerator Pump		Choke Pulldown Setting	Fast Idle Cam Setting	Choke Unloader Setting	Auto. Choke Setting
	Lever (Clearance)	Stroke (Hole No.)				
D9TE-BKA	.015"	No. 1	.212"	.210"	.315"	5 Rich