

1980 Exhaust Emission Systems

FORD MOTOR CO. ELECTRIC ASSIST CHOKE

DESCRIPTION

Some vehicles are equipped with an electrically assisted choke thermostatic spring heater to aid in fast choke release and to improve emission characteristics. Two types of chokes are used, a temperature sensitive type and a constant operating type. Both types operate from current supplied from the center tap of the alternator when the engine is running.

The temperature sensitive electric assist choke system consists of a choke cap, thermostatic spring, a bi-metal temperature sensing disc (switch), and a ceramic positive temperature coefficient (PTC) heater.

The constant operating type choke system consists of a choke cap, bi-metal spring, choke heater and a vacuum diaphragm and spring.

OPERATION

TEMPERATURE SENSITIVE TYPE

This system is grounded through a ground strap connected to the carburetor body. At temperatures below approximately 54-60°F, the switch is open and no current is supplied to the ceramic heater. Normal thermostatic spring choking action then occurs. At temperatures above approximately 54-60°F, the temperature sensing switch closes and current is supplied to the ceramic heater. As the heater warms, it causes the thermostatic spring to pull the choke plates open within 1 to 1½ minutes.

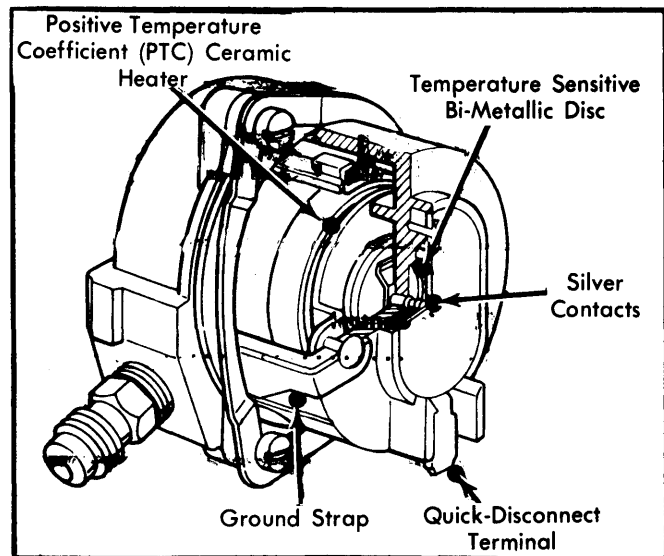

Fig. 1 Temperature Sensitive Type Electric Assist Choke

CONSTANT OPERATING TYPE

This system is installed between the choke thermostatic spring and the choke casting and heats whenever the engine is running. An overcenter spring is provided to assist in closing the choke plate for initial starting of a cold engine in high ambient temperatures. After the initial choke pull-down the overcenter spring has little or no effect on choke operation.

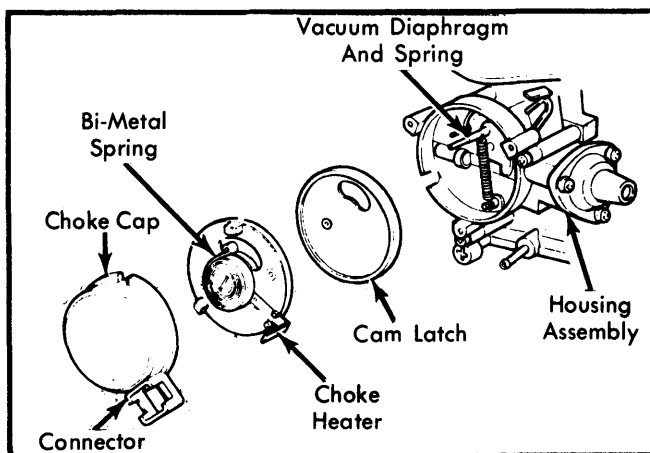

Fig. 2 Constant Operating Type Electric Assist Choke

TESTING

CHOKE CIRCUIT TEST

- 1) Disconnect stator lead at choke and connect a test light in series with stator lead wire and ground. With engine running, test light should glow.
- 2) If light does not glow, bypass the stator lead wire and connect test light in series with alternator stator terminal and ground. If light glows, repair or replace stator lead wire. If light does not glow, repair alternator as necessary.

CAP CONTINUITY TEST (TEMPERATURE SENSITIVE TYPE ONLY)

- 1) With engine off and air cleaner removed, connect 1 lead of a test light to choke cap terminal and touch the other lead to positive post of battery. If test light glows, choke cap contacts are closed. Remove test light and leads.
- 2) If test light does not glow, place an external heat source (100 watt light) against center of choke cap and hold test light lead to positive post of battery until test light glows, indicating cap contacts are closed, then quickly remove heat source and test light connections. Repeat test after several minutes. If light does not glow, replace choke cap.