

FORD MOTOR CO. TURBOCHARGING SYSTEM

Ford
Fairmont & Mustang
Mercury
Capri & Zephyr

DESCRIPTION

The Ford Motor Co. turbocharging system is used on the 2.3L 4-cylinder engine. The system includes a small turbocharger mounted on the left side of the engine, increased cooling, larger fuel tank and numerous engine modifications. Internal components such as bearings, pistons, lubrication system and valves have been strengthened or upgraded to withstand the additional power output. An ignition modification retards spark when the turbocharger is boosting intake pressure, helping to avoid detonation.

OPERATION

Air enters through the air filter and is mixed with fuel in the carburetor. The air/fuel mixture passes into the compressor assembly and into the intake manifold. When the engine is operating at low rpm, the compressor does not affect normal engine operation. As rpm increase, the flow of exhaust gas increases and speeds up the turbine assembly mounted in the exhaust system. Since the turbine is directly connected to the compressor, it begins to turn faster and force air into the engine. Since more fuel/air mixture is forced into the engine than can be drawn in with engine vacuum, the result is higher output.

Greater exhaust flow produces more compression of intake mixture, resulting in a cycle that would destroy the engine if there were no way to limit it. The wastegate assembly senses the amount of mixture compression (boost) and vents exhaust gases around the turbine when boost reaches a predetermined

level. This action is absolutely necessary to maintain engine life, and should any problem occur that causes over-boost or high oil temperatures, the driver will be signaled by a warning light and buzzer.

The higher combustion chamber pressures developed in a turbocharging system create problems with detonation. To prevent engine damage, Ford's system is designed to retard engine timing 6° when boost pressure reaches 1 psi, and another 6° at 4 psi. The maximum boost permitted by the wastegate system is 6 psi.

The increased engine load requires a more extensive oil supply system. Capacity and oil pressure are increased in the turbocharged engine. The compressor assembly can reach speeds of 140,000 rpm, and lubrication is essential to prevent self-destruction of the compressor. Whenever any kind of engine work that involves disassembly of components is done, or turbocharger disassembly, engine oil and filter should be changed.

TESTING

VACUUM/PRESSURE SYSTEM CHECK

- 1) Remove pressure hose from intake manifold fitting. Apply 7 psi to line and observe movement of wastegate activating rod.
- 2) If wastegate rod moves, remove pressure hose and reinstall manifold line.
- 3) If wastegate rod does not move, check for leaks at distributor diaphragm, boost retard switch, boost light switch and all hoses and lines.

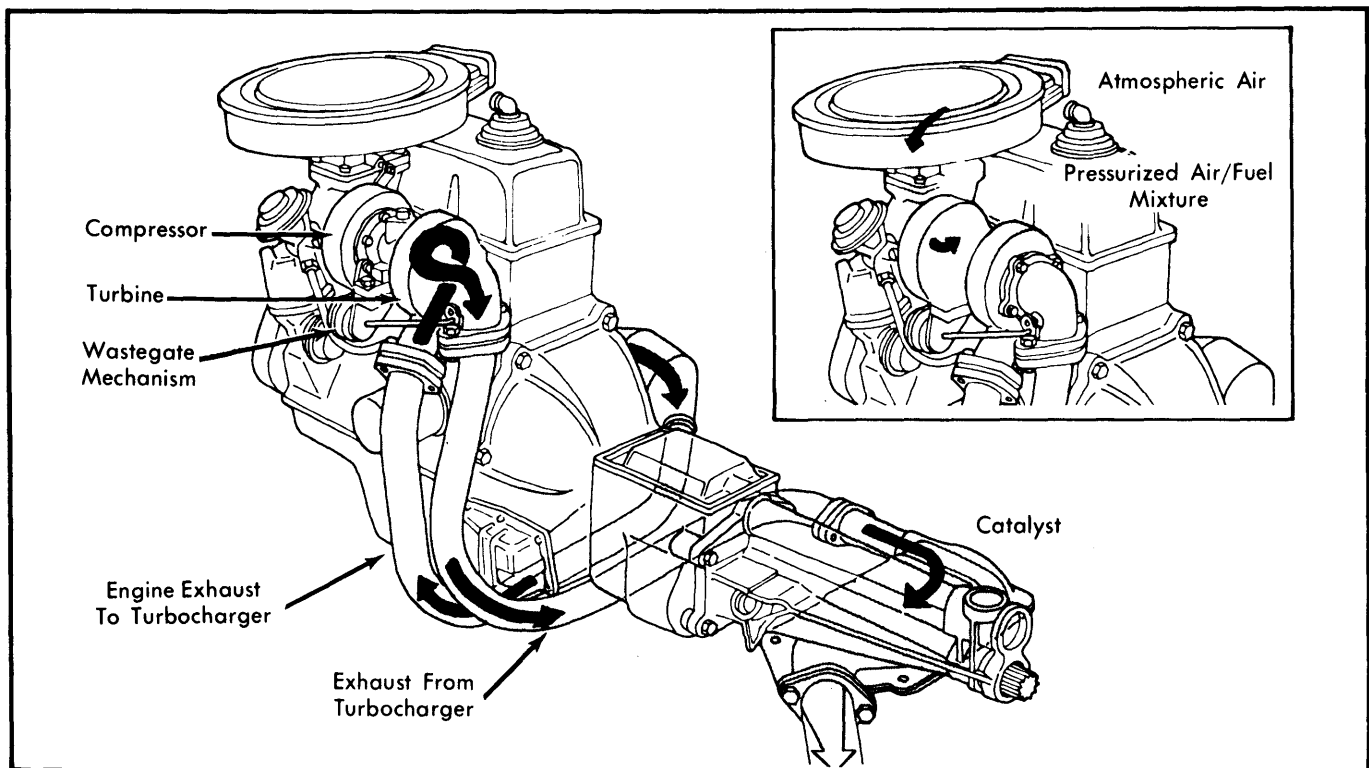

Fig.1 Ford Motor Co. Turbocharging System

FORD MOTOR CO. TURBOCHARGING SYSTEM (Cont.)

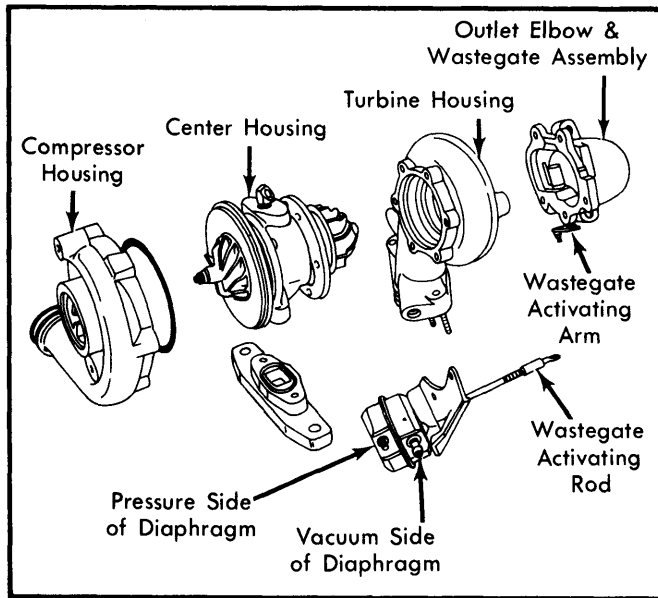

Fig. 2 Turbocharger Components

WASTEGATE ACTIVATING DIAPHRAGM CHECK

- 1) Check that activating rod is in place and retained by clip. Correct as required.
- 2) Remove lines from diaphragm and attach a vacuum source to vacuum side of diaphragm. Apply 25 in. Hg and trap. If vacuum drops below 18 in. Hg after 60 seconds, replace wastegate activating diaphragm.
- 3) Install an external pressure source to the pressure side of the diaphragm. Apply 5 psi and trap. If the pressure drops below 2 psi after 60 seconds, replace wastegate activating diaphragm. If pressure does not drop, release, but do not remove pressure source and hose.

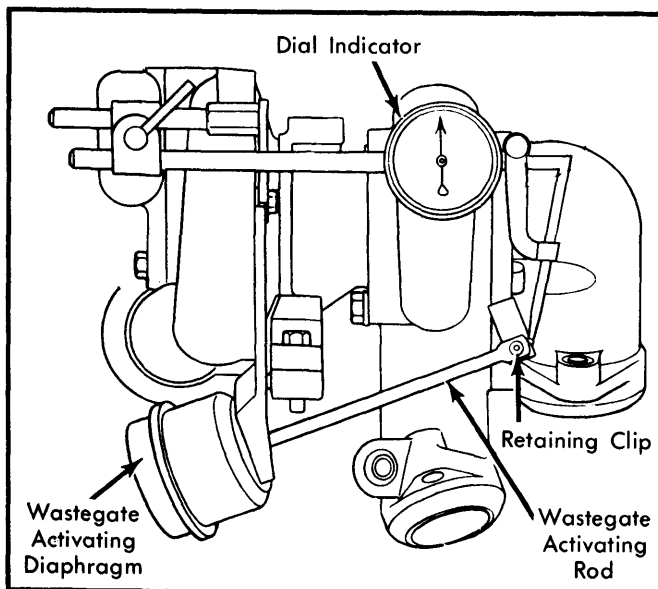

Fig. 3 Checking Wastegate Activating Rod Travel

- 4) Install a dial indicator to measure travel of wastegate activating rod. Apply pressure VERY SLOWLY until dial indicator shows .015" movement. Pressure gauge should read $6.8 \pm .5$ psi. If wastegate arm does not meet specification or move freely, replace wastegate activating diaphragm. See Fig. 3.

OUTLET ELBOW & WASTEGATE ASSEMBLY

- 1) Remove retaining clip from wastegate activating rod and check wastegate arm for free rotation (minimum of 40°). If not to specification, replace outlet elbow and wastegate assembly.
- 2) Remove turbocharger outlet pipe assembly. Check to see that wastegate sealing poppet is free to move on pintle and is seated on turbine housing by-pass hole. If not, clean hole and sealing surface or replace outlet elbow and wastegate assembly.

CAUTION — Use care to prevent any foreign material from entering turbine housing. Contamination will result in destruction of the turbine assembly.

- 3) Pressurize the wastegate diaphragm to 6 psi to aid in reinstallation of the wastegate activating rod. Reinstall rod and retaining clip.

INTERNAL INSPECTION

COMPRESSOR OIL SEAL

- 1) Remove turbocharger assembly from the engine.
- 2) Remove wastegate activating rod clip and rod. Scribe a line across compressor housing and backing plate to aid in reassembly.
- 3) Remove 6 compressor housing bolts. Remove wastegate activating diaphragm and detach compressor housing from backing plate.
- 4) Check for excessive oil on compressor wheel, backing plate and housing inner surface. If excessive oil is detected, replace turbocharger assembly.
- 5) Inspect compressor wheel for blade erosion, cracking, damage, rubbing or slipping on shaft. Check for rubbing or scraping. If any of these conditions exist, replace turbocharger assembly.

TURBINE OIL SEAL

- 1) Remove turbocharger assembly from engine.
- 2) Remove wastegate activating rod clip and rod. Scribe a line across turbine housing to aid in reassembly.
- 3) Remove 6 turbine housing bolts. Remove turbine housing from center housing.
- 4) Check for excessive oil on turbine wheel, housing and turbine heat shield. If excessive oil is detected, replace turbocharger assembly.

FORD MOTOR CO. TURBOCHARGING SYSTEM (Cont.)

5) Inspect turbine wheel for blade erosion, damage, cracking or burning. Check for rubbing or scraping and make sure blades do not have combustion by-product buildup. If any of these conditions exist, replace turbocharger assembly.

RADIAL CLEARANCE CHECK

- 1) Remove turbocharger assembly from engine.
- 2) Remove wastegate activating rod clip and rod from activating arm.
- 3) Remove 5 bolts connecting turbine outlet elbow to housing. One bolt is located inside elbow housing. Remove housing from turbocharger assembly.
- 4) Attach suitable dial indicator with 3" extension rod (4201-C and 4201-A) to center housing so indicator plunger extends through oil outlet port and contacts shaft of turbine wheel assembly. See Fig. 4.

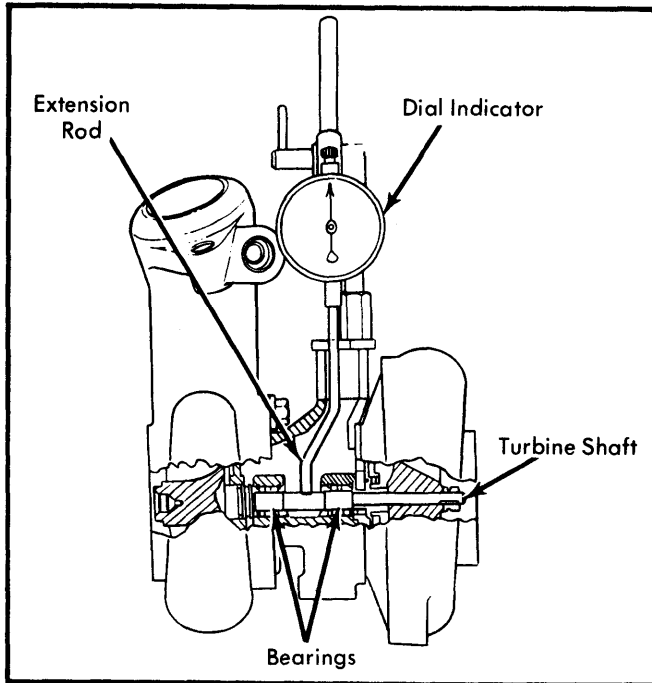

Fig. 4 Checking Radial Bearing Clearance With Dial Indicator

- 5) Manually apply equal pressure to both turbine and compressor wheels to move shaft AWAY from dial indicator extension rod. Set indicator to ZERO.
- 6) Manually apply equal pressure to both the turbine and compressor wheels to move shaft TOWARD dial indicator. Roll the wheels slightly in each direction to make sure shaft has moved as far as it will go. Record maximum reading on indicator gauge.
- 7) Manually apply equal pressure to both wheels to move shaft AWAY from dial indicator. The indicator pointer should be at ZERO.
- 8) Repeat procedure until sure maximum reading has been obtained. If maximum radial bearing clearance is not within .003-.006", replace turbocharger assembly.

AXIAL CLEARANCE CHECK

- 1) Remove turbocharger assembly from engine.
- 2) Remove wastegate activating rod clip and rod from activating arm.
- 3) Remove 5 bolts connecting turbine outlet elbow to housing. One bolt is located inside elbow housing. Remove elbow from turbocharger assembly.
- 4) Attach a suitable dial indicator (4201-C) at the turbine end of the turbocharger assembly so the tip rests on the end of the turbine wheel assembly. See Fig. 5.

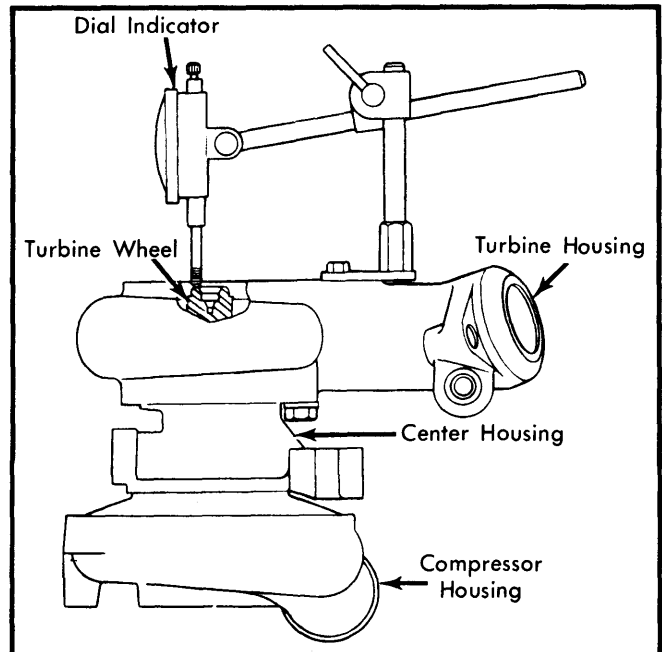

Fig. 5 Checking Axial Bearing Clearance With Dial Indicator

- 5) Manually move the compressor wheel and turbine wheel assembly alternately away from and toward the turbine end of turbocharger assembly. Note the travel of the shaft shown by dial indicator.
- 6) Repeat procedure until sure maximum travel has been indicated. If maximum thrust bearing clearance is not within .001-.003", replace turbocharger assembly.
- 7) If turbocharger meets all specifications, remove test equipment, reinstall by reversing removal procedure and tighten bolts to specification.

TIGHTENING SPECIFICATIONS

Application	INCH Lbs.
Compressor Housing Bolts	145-165
Turbine Housing Bolts	164-181
Outlet Elbow and Wastegate Bolts	164-181