

## GENERAL MOTORS ELECTRONIC FUEL INJECTION

**Cadillac  
Eldorado & Seville  
(California Only)**

### DESCRIPTION

This electronic fuel injection system (EFI) basically consists of four sub-systems: Fuel delivery, air induction, engine sensors and the electronic control unit (ECU). The fuel delivery system includes a chassis mounted electric fuel pump, an in-tank boost pump, engine mounted fuel filter, fuel rail, injectors, fuel pressure regulator and fuel supply and return lines.

The air induction system consists of throttle body, fast idle valve, idle air compensator and intake manifold. Engine sensors are as follows: Manifold absolute pressure (MAP), throttle position switch, coolant and air temperature sensors, and a speed sensor. The fourth system is the ECU.

This combination of sub-systems, working together, creates a two group timed port injection system. The two groups are based upon engine firing order; the first group consists of cylinders 1, 2, 7 and 8; the second group is made up of the center four cylinders, 3, 4, 5 and 6. All four injectors in either group are actuated at the same time and the separate groups are actuated alternately.

Seville models include a solenoid operated idle air compensator to control idle speed when the A/C compressor is operating. All models use a "Closed Loop" fuel injection system. This system uses an oxygen sensor, located in the left side exhaust manifold, to sense oxygen content in exhaust

gases. Differently calibrated ECUs are used for each model and cannot be interchanged.

### OPERATION

#### GENERAL

The amount of air entering the engine is measured by monitoring the intake manifold absolute pressure, the intake air temperature, and the engine speed. This information allows the electronic control unit to compute the flow rate of fuel required to achieve the desired air/fuel ratio for the particular engine operating condition. Each of the injector groups are activated once for every revolution of the camshaft or once for every two revolutions of crankshaft. The ECU converts the multi-variable information (see illustration) into an injector pulse width which opens the injectors for the proper duration and at proper time with respect to cylinder firing sequence.

#### CLOSED LOOP EFI SYSTEM

Closed Loop EFI system is used on all models. The closed loop system uses an oxygen sensor, in exhaust manifold, to sense oxygen content in exhaust gases. The oxygen sensor is an electromechanical device which produces a variable voltage depending upon oxygen content in exhaust gases. The variable voltage is sent to the ECU to signal it to regulate the amount of fuel injected. With this system, air/fuel ratio is maintained at the ideal ratio of 14.7 to 1.

#### AIR INDUCTION SYSTEM

Air for combustion enters engine through throttle body at a rate controlled by the throttle valves, which are connected to

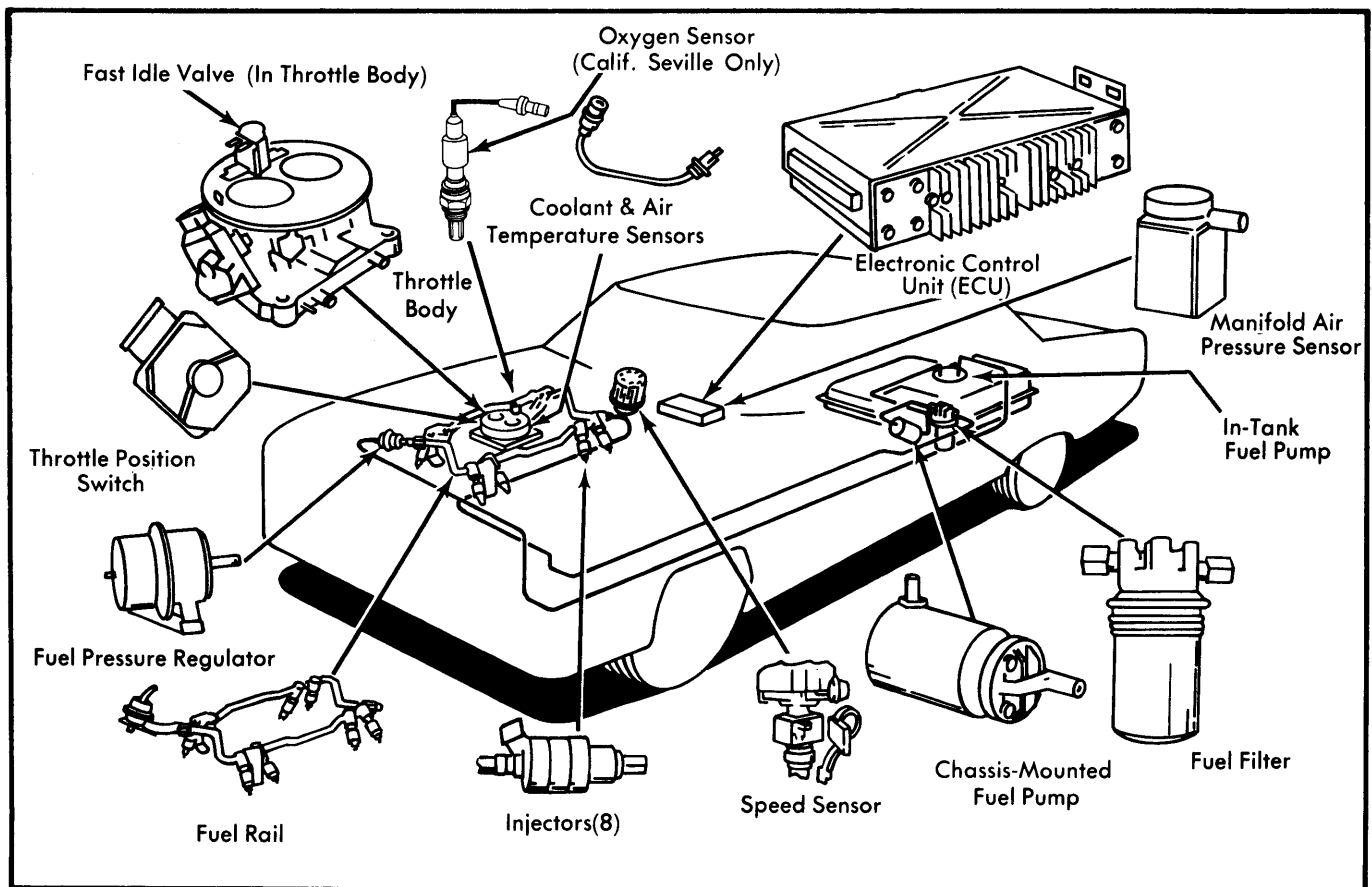

**Fig. 1 Electronic Fuel Injection System Components & Locations (Typical)**

## GENERAL MOTORS ELECTRONIC FUEL INJECTION (Cont.)

accelerator pedal linkage. An adjustable idle by-pass air passage is incorporated within the throttle body that allows a regulated amount of air to by-pass the throttle valves. The throttle valves are pre-set to slightly open position, even when throttle lever is resting against the idle stop position.

**NOTE** — This pre-set position is not adjustable. Additional air for cold starting is provided through an electrically operated (controlled) fast idle valve which is incorporated into top of throttle body.

Idle air bypass adjusting screw is a spring-loaded slot-head type. A solenoid operated idle air compensator is used on Seviles to aid in smooth idle with A/C compressor engaged.

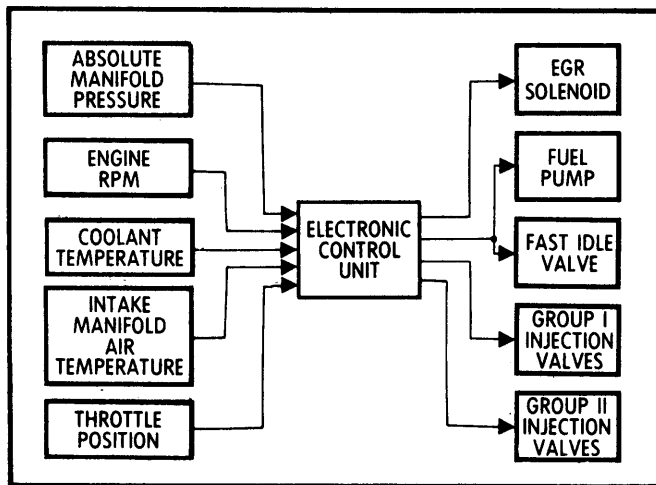

Fig. 2 Block Diagram Of EFI Electronic Functions

### FUEL DELIVERY

**Fuel Pumps** — Two electric fuel pumps are used on vehicles with EFI system. Located inside fuel tank, as an integral part of fuel gauge sending unit, the in-tank pump is used to supply fuel to chassis-mounted (main) pump. Purpose of this pump is to prevent vapor lock at suction side of main pump. The chassis-mounted main pump is constant displacement roller-vane type pump. This main pump has flow rate of 33 gallons per hour at 39 psi. Both fuel pumps are actuated by electronic control unit when ignition switch is "ON" and engine is either cranking or running.

**NOTE** — Both fuel pumps will deactivate in about one second if engine stalls or starter is not engaged.

**Fuel Pressure Regulator** — This unit maintains a constant 39 psi, above intake manifold absolute pressure, to the injectors. Excess fuel is returned to fuel tank via return lines. The regulator is located toward front of engine on fuel rail.

**Injectors** — Injectors are solenoid-operated pintle valves which meter fuel to each cylinder. To furnish adequate fuel under different engine operating conditions, the ECU controls length of time pintle is retracted and fuel is being injected.

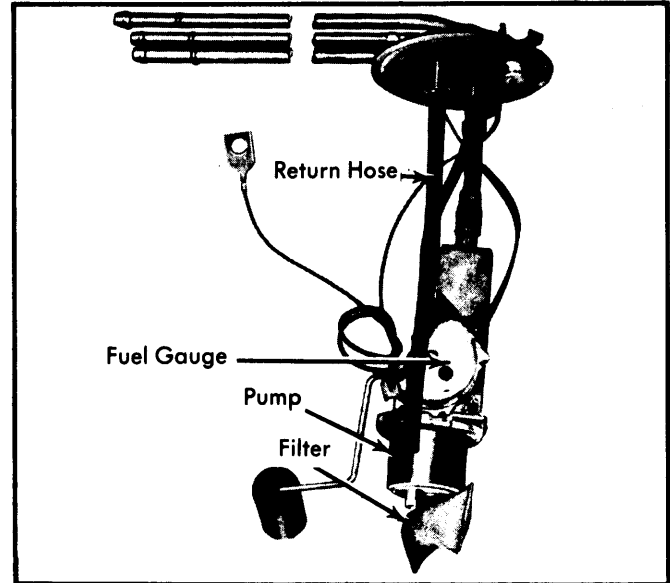

Fig. 3 View Of In-Tank Boost Pump

### ENGINE SENSORS

Each sensor furnishes an electronic signal to ECU, modifying the injection time commands which changes the fuel injection rate to conform with operating conditions of engine. These sensors are explained as follows:

**Manifold Absolute Pressure (MAP)** — This sensor monitors changes in intake manifold pressure which results from engine load, speed and barometric pressure variations. As intake manifold pressure increases, additional fuel is required. MAP sends this information to ECU so that the pulse width is increased (time injector is open). Conversely, as manifold pressure decreases, pulse width is shortened.

**Throttle Position Switch** — This slide switch is mounted on side of throttle body and connected directly to throttle shaft. This switch senses shaft movement and positions and transmits appropriate electrical signals to ECU. Four basic signals are sent to ECU. First, when throttle is closed (idle position) signal sent to ECU helps to determine basic pulse width. Second signal is sent to ECU when accelerating and ECU provides additional pulses to enrich fuel mixture. Third signal is needed for wide open throttle. Fourth signal is also wide open throttle, but with engine not running. This wide open throttle (W.O.T.) signal provides for clearing a flooded engine.

**Temperature Sensors** — Both coolant temperature sensor and air temperature sensor are exactly same and therefore interchangeable. These sensors consist of a coil of high temperature nickel wire which changes internal resistance according to temperature. Low temperature produces low resistance.

**Speed Sensor** — Located just below base plate of HEI distributor, the speed sensor consists of two components. First component is two reed switches mounted within a plastic housing, second component is plastic rotor with two magnets (called flags), attached to and rotating with distributor shaft. Each flag furnishes signal for each injection group. As flags rotate

## GENERAL MOTORS ELECTRONIC FUEL INJECTION (Cont.)

past reed switches, the switches open and close and this information is sent to ECU. This type of signal is basically a tachometer reading for each group of injectors.

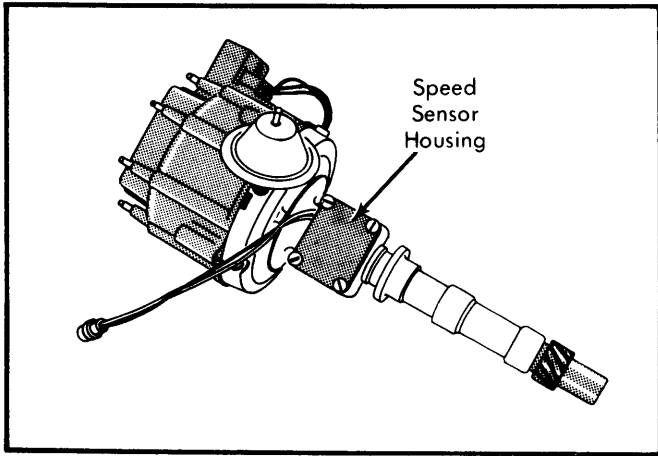

Fig. 4 HEI Distributor With Speed Sensor (Trigger)

### ELECTRONIC CONTROL UNIT (ECU)

The ECU is a preprogrammed analog computer which is installed behind instrument panel on the right side. It is electrically connected to vehicle power supply and to the components of the EFI system. As signals are received from sensors, the ECU processes the signals and commands injectors to open for a specific time duration. The duration of an injection (pulse width) varies as the engine operating conditions change. The desired air fuel ratios for any possible combination of driving or atmospheric conditions is programmed into the ECU.

### TROUBLE SHOOTING

**NOTE** — The fuel injection analyzer (J-25400) will functionally test each component of the system as well as the ECU. However, there are many problems which can be solved (without this analyzer) by following the diagnostic procedure. To aid in diagnosis, the table below indicates the approximate relationship between basic carburetor components and electronic fuel injection components.

**NOTE** — A driveability problem on an EFI equipped vehicle may sometimes be the fault of an improperly positioned EGR valve gasket or having the wrong gasket installed.

#### Carburetor-to-EFI Comparison

Carburetor	EFI Component
Accelerator Pump .....	Throttle Position Switch
Fast Idle Cam .....	Electric Fast Idle Valve
Float .....	Fuel Pressure Regulator
Power Valve/Metering Rods .....	MAP Sensor
Metering Jets/Idle System .....	Injection Valves/ECU
Idle Solenoid .....	Idle Air Compensator

### ENGINE CRANKS BUT WILL NOT START

1) Blown 20 amp. fuse at fuse block. Turn ignition switch to "ON" (not "START") position and listen for 1 second pump whine.

**NOTE** — Use only 20 amp. fuses (not "SLOW-BLOW"). These fuses are of flat wafer type and must be replaced with equivalent. Use of larger amperage fuses may damage expensive ECU unit.

2) If fuse continually blows, check for short circuit in light blue wire at ECU. Light blue wire showing short should be disconnected at fuel pump connections and retested. If no short is found in wire, check chassis mounted fuel pump, wire to in-tank fuel pump and in-tank fuel pump for short circuits.

3) Open circuit in purple or brown wire between starter solenoid and blue connector at ECU. Listen for a 1 second whine of fuel pump when ignition switch is turned to "ON" position.

4) Poor connection at ECU terminal connectors, fuel pump jumper harness, engine temperature sensors or at distributor trigger (speed sensor). To check engine temperature sensors, connect an ohmmeter across each sensor connector (disconnected). If ohmmeter reading is not between 600 and 1600 ohms (the higher the temperature the higher the ohm reading), replace sensor.

5) Malfunction in chassis mounted fuel pump. Check voltage of wire at pump connection.

6) Malfunction of throttle position switch. To check, disconnect switch and engine should start.

**CAUTION** — Fuel system is under approximately 39 psi; therefore, the following procedure should be followed when relieving pressure from fuel system: remove protection cap from pressure fitting of fuel pressure valve and loosely install special tool (J-5420) on fitting. Arrange shop towel or suitable container so that discharged fuel will be contained. Slowly tighten special tool until pressure is relieved.

7) Fuel flow restriction. Check by disconnecting pump outlet line and turning ignition switch to "ON" position, if fuel flow is abnormal, continue disconnecting fuel supply lines until fuel tank is reached.

### HARD STARTING

1) Engine coolant temperature sensor has open circuit. Indication of this condition is that it will start normally when engine is hot, but is hard to start when engine is cold or only partially warm. To check sensor, connect an ohmmeter across sensor connector (disconnected). If ohmmeter reading is more than 1600 ohms, replace sensor.

2) Malfunction in throttle switch. To check, disconnect switch and engine should start normally.

**CAUTION** — Fuel system is under approximately 39 psi; therefore, the following procedure should be followed when relieving pressure from fuel system: remove protection cap from pressure fitting of fuel pressure valve and loosely install special tool (J-5420) on fitting. Arrange shop towel or suitable container so that discharged fuel will be contained. Slowly tighten special tool until pressure is relieved.

3) Malfunction in pump or pressure regulator. To check, test pressure of fuel supply system.

## GENERAL MOTORS ELECTRONIC FUEL INJECTION (Cont.)

### POOR FUEL ECONOMY

- 1) Disconnected or leaking MAP sensor. Replace or repair as necessary.
- 2) Disconnected vacuum hose at fuel pressure regulator or at throttle body. Check all vacuum connections.
- 3) Malfunction of air temperature sensor. Check for closed (shorted) circuit in temperature sensor by connecting an ohmmeter across connector terminals. If sensor resistance is less than 600 ohms, replace sensor.

### ENGINE STALLS AFTER STARTING

- 1) Check for open circuit in pink (gray at ECU) wire from ignition switch to black connector at ECU or for poor connection at ECU terminal connectors, which is located below instrument panel near ECU.
- 2) Check for poor connection at engine coolant sensor. Check for open circuit in sensor wire or in sensor wiring connector. To check for open circuit in sensor, connect ohmmeter across disconnected sensor terminals, if resistance is greater than 1600 ohms, replace sensor.
- 3) Check idle air compensator for stalling after start or at idle. When compensator is working properly, an increase in air noise will be heard when A/C compressor cuts in. Idle RPM with A/C ON and transmission in DRIVE should be within about 30 RPM of the normal A/C OFF idle speed. Under extremely warm conditions, this difference in RPM may be greater. If electrical connections to compensator and compressor are good, compensator valve may be sticking and should be replaced.

### ROUGH IDLE

- 1) Check for disconnected or leaking MAP sensor hose.

**NOTE** — If plastic harness line requires replacing, replace entire EFI engine harness.

- 2) On cold engine only, check for poor connection at temperature sensors or for possible open circuit at sensors. To check for open circuit, connect ohmmeter across disconnected sensor terminals, if resistance is greater than 1600 ohms, replace sensor.
- 3) Check for poor connection at injector wiring.
- 4) Check engine coolant sensor for shorted (closed) circuit. To check, connect ohmmeter across disconnected sensor terminals. If resistance is less than 600 ohms, replace sensor.
- 5) Speed sensor harness located too close to secondary ignition wires.

### PROLONGED FAST IDLE

- 1) Check for possible poor connection at fast idle valve or for an open circuit in fast idle valve heating element.
- 2) Check adjustment of throttle position switch.
- 3) Check for possible vacuum leaks.

### NO FAST IDLE

Check for bent fast idle valve micro-switch causing heater to malfunction and drive valve section down to locked closed position.

### ENGINE HESITATES OR STUMBLES ON ACCELERATION

- 1) Check for disconnected, leaking or pinched MAP sensor hose.

**NOTE** — If plastic harness line requires replacing, replace entire EFI engine harness.

- 2) Check for electrical malfunction or mechanical alignment malfunction of throttle position switch.
- 3) Check for intermittent malfunction of distributor trigger (speed sensor).
- 4) Check 6 Pin connector, on ECU, for loose connection. Check EGR solenoid for loose connection or open circuit (cold engine only).

### LACK OF HIGH SPEED PERFORMANCE

- 1) Check throttle position switch for proper alignment at wide open throttle (W.O.T.). Also check for any other malfunctions in throttle positioning switch.
- 2) Check for malfunction of chassis mounted fuel pump.
- 3) Check for intermittent malfunction of distributor trigger (speed sensor).

**CAUTION** — Fuel system is under approximately 39 psi; therefore, the following procedure should be followed when relieving pressure from fuel system: remove protection cap from pressure fitting of fuel pressure valve and loosely install special tool (J-5420) on fitting. Arrange shop towel or suitable container so that discharged fuel will be contained. Slowly tighten special tool until pressure is relieved.

- 4) Check fuel system for restriction.
- 5) Check for open circuit in purple wire between ECU and starter solenoid.

## GENERAL MOTORS ELECTRONIC FUEL INJECTION (Cont.)

### REMOVAL & INSTALLATION

**CAUTION** — Fuel system is under approximately 39 psi; therefore, the following procedure should be followed when relieving pressure from fuel system: remove protection cap from pressure fitting of fuel pressure valve and loosely install special tool (J-5420) on fitting. Arrange shop towel or suitable container so that discharged fuel will be contained. Slowly tighten special tool until pressure is relieved.

### ELECTRONIC CONTROL UNIT

**Removal** — Disconnect battery negative cable. Remove instrument panel lower cover. Remove mounting screw from front of ECU. Remove screws (2) attaching ECU to instrument lower panel. Disconnect harness connectors and MAP hose.

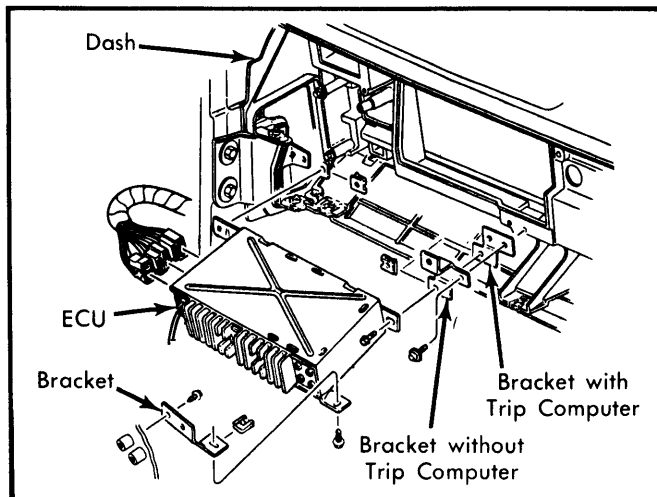

Fig. 5 ECU Mounting Location

**Installation** — Connect harness connectors and MAP hose to ECU. Attach ECU to instrument lower panel and install front screw to ECU. Install instrument panel lower cover and connect negative battery cable.

### THROTTLE BODY ASSEMBLY

**Removal** — 1) Remove air cleaner, disconnect throttle return springs and if equipped, remove retainer from cruise control. Remove hairpin clip, to disconnect throttle cable from throttle lever. Remove left rear throttle body mounting screws which holds throttle bracket to intake manifold. Disengage downshift switch from throttle lever and move switch and bracket out of the way. Disconnect throttle position switch electrical connection, idle air compensator solenoid valve wire and fast idle valve connection.

2) Slide fast idle valve wiring out of notch in throttle body. Using back-up wrench, remove power brake vacuum line. From nipples on throttle body, remove vacuum hoses. Remove remaining throttle body mounting screws and remove throttle body. Remove gasket material from intake manifold and bottom of throttle body. Clean all foreign material from around intake throttle bores, on intake manifold.

**Installation** — 1) Position new throttle body gasket to intake manifold, with identification tag to left. Install throttle position switch to right of throttle body and adjust switch. Position throttle body on intake manifold and loosely install both front and rear mounting screws. Move throttle linkage bracket into position over left rear mounting screw and install throttle body mounting screw.

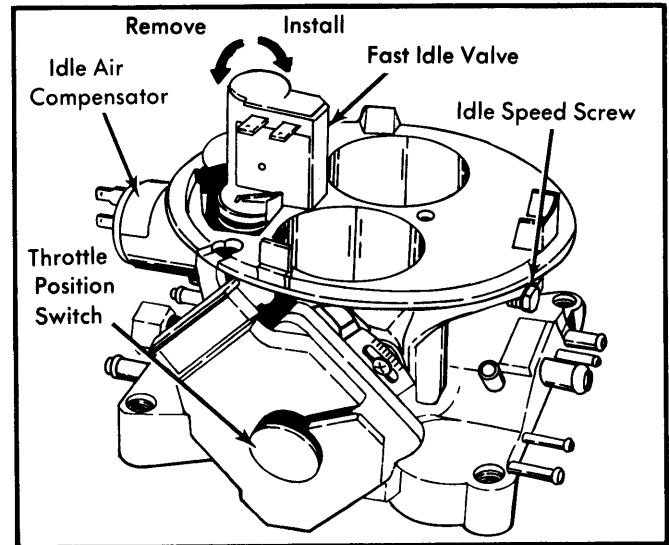

Fig. 6 External View of Throttle Body Assembly

2) Install additional bracket mounting screw and tighten all screws to specifications. Position throttle cable to throttle lever and secure cable with hairpin clip. Check operation of transmission downshift switch. Check for proper operation and wide open throttle (W.O.T.). On vehicles so equipped, position cruise control chain to throttle lever and secure with clip. Install power brake vacuum fitting to rear of throttle body and tighten bracket while using back-up wrench.

3) Install throttle return springs between throttle lever and pressure regulator bracket, with open end of spring on outside of throttle lever. Install vacuum hoses to nipples on throttle body. Install fast idle valve and air cleaner.

### THROTTLE POSITION SWITCH

**Removal** — Disconnect electrical connection to throttle position switch. Remove 2 screws mounting throttle switch to throttle body and remove throttle switch.

**Installation** — Install throttle position switch to right side of throttle body, so that tab on switch engages with flat on throttle shaft. Install 2 mounting screws and tighten so that switch will move, but is not loose. Adjust throttle position switch.

### FAST IDLE VALVE

**Removal** — Remove air cleaner and disconnect electrical connector from fast idle valve heater. Remove air cleaner stud. To remove fast idle valve heater, push down and twist 90° counterclockwise. Remove fast idle valve spring and seat from throttle body.

**Installation** — Install fast idle valve seat, spring and valve in position in throttle body. Position heater on top of fast idle valve and push down to compress spring.

## GENERAL MOTORS ELECTRONIC FUEL INJECTION (Cont.)

**NOTE** — Exercise care to avoid damaging micro-switch contact arm on bottom of heater housing. Align tabs of fast idle valve heater with cutout position of throttle body and compress spring further. Rotate heater 90° clockwise and connect electrical connector. Install air cleaner.

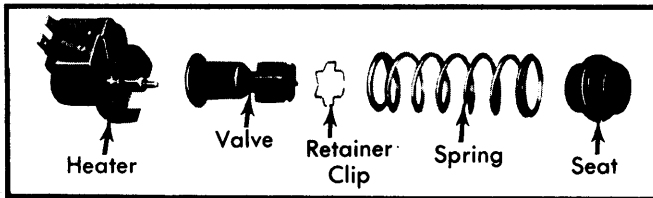

Fig. 7 Exploded View of Fast Idle Valve

## INJECTION VALVE (INJECTORS)

**Removal** — 1) Remove front and rear fuel rails. Remove electrical conduit from injector brackets. Remove two screws holding each injector bracket to intake manifold and remove brackets and rubber grommets. Disconnect electrical connections from all injectors.

2) Remove fuel rails and injectors from engine, as a unit.  
**NOTE** — Some injectors will stick in fuel rail, while others will remain with manifold. Remove injectors from fuel rail and from intake manifold. Injection valves are sealed by "O" rings at both fuel rail and intake manifold, remove and discard all "O" rings.

**NOTE** — Anytime EFI fuel rail fitting is separated, a new conically shaped metal gasket (part no. 1608786) should be installed. Do not reuse this gasket, replace each time a fitting is disconnected. Also, do not use teflon tape on fitting flare nuts.

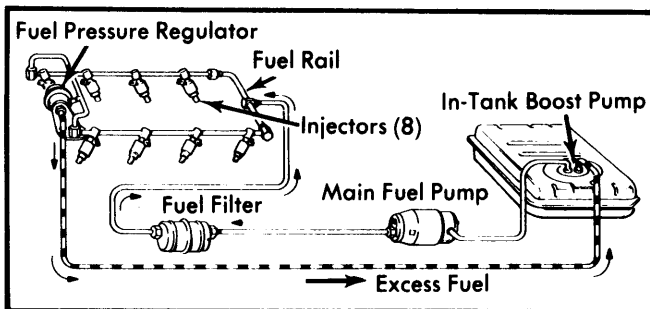

Fig. 8 Typical Cadillac EFI Fuel Delivery System

**Installation** — 1) Lubricate and install all new "O" rings on fuel rail side of injectors. Install injectors into fuel rail with electrical connector facing inboard. **NOTE** — Fuel rails are left and right side only and cannot be interchanged. Lubricate and install new "O" rings into each injector port of intake manifold.

2) Install fuel rail injector assembly into intake manifold making sure that each injector is properly installed in manifold "O" rings. Install rubber grommets on fuel rail (flange down) and install injector brackets in position. Secure each bracket with two screws and tighten screws to specifications.

3) Route electrical harness along bracket and secure to bracket. **NOTE** — Injectors may be rotated to provide proper harness routing. Install front and rear fuel rails. Turn ignition switch to ON position then turn to OFF. Perform this procedure several times to ensure that fuel rail has no leaks.

## FUEL PRESSURE REGULATOR

**Removal** — Remove vacuum hose from nipple on top of pressure regulator. Remove and discard clamps securing flexible fuel hose connecting regulator to fuel rail. Remove fuel return line. Remove nut securing pressure regulator to fuel rail.

**NOTE** — This nut has metric threads. Work regulator off of flexible fuel hose and out of bracket.

**Installation** — 1) Install new hose clamp over flexible fuel hose. Position regulator to bracket and work flexible fuel hose-to-fuel rail over nipple on side of regulator. Secure bracket with one nut. **NOTE** — This nut has metric threads. Connect return line to fitting on end of regulator.

2) Tighten clamps securing flexible fuel hose to regulator. Install vacuum hose to remaining nipple on pressure regulator.  
**NOTE** — Dry fuel system on vehicle with EFI may require substantial cranking before it will start.

## FUEL FILTER ASSEMBLY

**Removal** — Remove fuel inlet hose and discard clamp. Remove fuel outlet line from fitting of fuel filter. Remove two screws securing fuel filter assembly to bracket and remove filter. Remove inlet and outlet fittings from fuel filter assembly (if needed for new assembly). If it is necessary to remove fuel filter bracket, loosen lower mounting screw and remove upper mounting screw. Remove bracket and clean gasket surfaces.

**Installation** — If bracket was removed, position gasket to block (using gasket cement to hold in place) and start bottom screw. Position bracket to block, install upper mounting screw and tighten both screws. Install inlet and outlet fittings in fuel filter assembly. Position fuel filter to bracket and secure with 2 screws. Connect fuel inlet line and outlet line to fuel filter fittings.

**NOTE** — Dry fuel system on vehicle equipped with EFI, may require substantial cranking before engine will start.

## CHASSIS-MOUNTED FUEL PUMP

**NOTE** — Chassis-mounted fuel pump is located in front of left rear wheel on all models.

**Removal** — Remove fuel inlet and outlet hoses from nipples of pump. Peel back rubber boot and remove 2 nuts; one from each electrical terminal. Remove electrical leads.

**NOTE** — These nuts have metric threads. Remove 2 screws securing pump to bracket and remove pump. Disconnect inlet and outlet hoses by removing and discarding hose clamps.

**Installation** — Position fuel pump to mounting bracket and secure with two screws. Tighten screws to specifications. Position electrical leads to fuel pump terminals as follows: dark green wire to positive terminal and black wire to negative terminal. Secure with two nuts and reposition rubber boot.

**NOTE** — Use new nuts supplied with replacement pump. Install inlet and outlet hoses to fuel pump. Check to ensure fuel pump is resting on its two mounts and that it is not grounding against bracket or frame. **NOTE** — Dry fuel system may require substantial cranking before vehicle will start.

## GENERAL MOTORS ELECTRONIC FUEL INJECTION (Cont.)

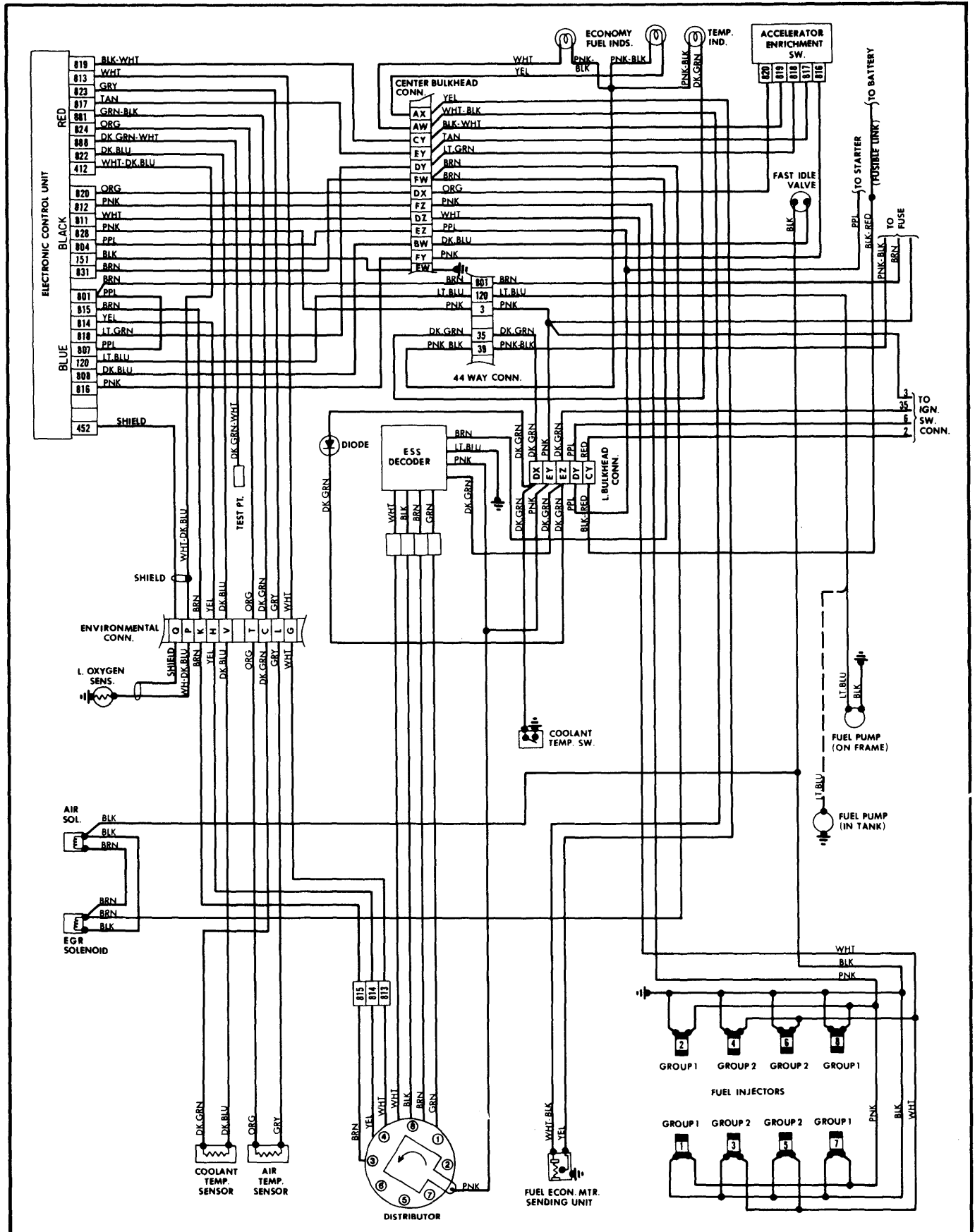

Fig. 9 General Motors Electronic Fuel Injection Wiring Diagram

## GENERAL MOTORS ELECTRONIC FUEL INJECTION (Cont.)

## IN-TANK FUEL PUMP

**Removal** — With fuel tank removed, remove locknuts securing fuel gauge tank unit and fuel pump feed wires to tank unit. Position fuel tank sending unit remover and installer (special tool J-24187) on cam locking ring, so that tool engages three tabs on ring. Install ratchet and turn counterclockwise to disengage lock ring from fuel tank. Remove tool and lift out tank unit.

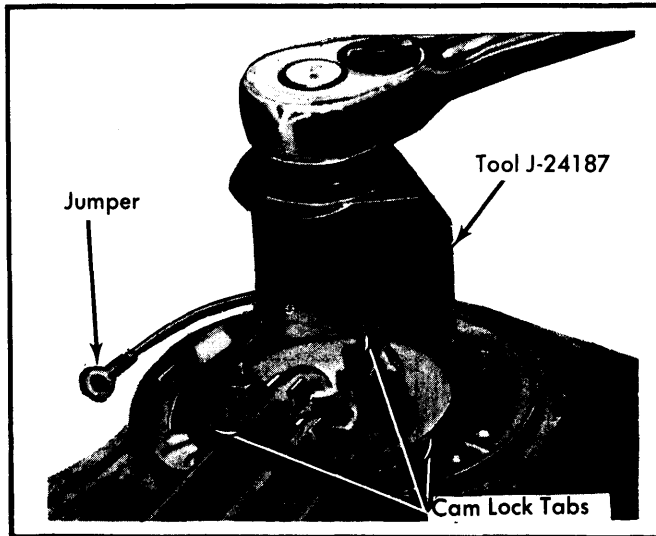

Fig. 10 Removing and Installing In-Tank Fuel Pump

**Installation** — Install gauge-pump unit in fuel tank. Install fuel tank sending unit remover and installer tool (J-24187). Turn tool clockwise until locking ring is fully engaged in fuel tank. Connect electrical leads to fuel gauge and secure with locknuts. Install fuel tank. **NOTE** — Dry fuel system may require substantial cranking before vehicle will start.

## AIR TEMPERATURE SENSOR

**Removal** — Locate air temperature sensor at right rear of intake manifold and disconnect sensor from vehicle harness. Remove sensor from intake manifold.

**Installation** — Apply non-hardening sealer to threads of sensor and install sensor in intake manifold. Tighten sensor to specifications. Connect sensor electrical connection to vehicle harness.

## COOLANT TEMPERATURE SENSOR

**Removal** — Drain radiator until coolant is below level of cylinder heads. Locate water temperature sensor at left front of intake manifold. Disconnect harness from sensor and remove sensor.

**Installation** — Apply non-hardening sealer to threads of sensor and install in sensor fitting. Tighten sensor to specifications. Connect sensor electrical connector to vehicle wiring harness. Fill radiator to proper level.

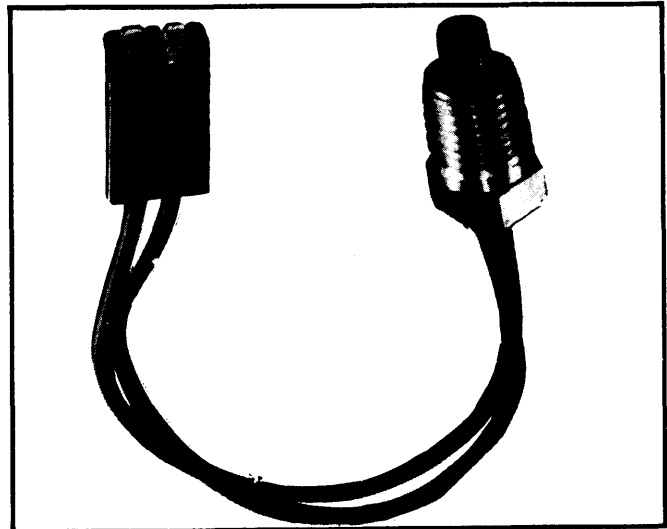

Fig. 11 Temperature Sensor  
ADJUSTMENT

## IDLE SPEED ADJUSTMENT

- 1) Disconnect distributor vacuum advance hose at distributor and plug. Disconnect parking brake hose at vacuum release cylinder and plug.
- 2) Engage parking brake and block wheels.
- 3) Connect tachometer to engine. Start engine and warm up to operating temperature in PARK.
- 4) Place transmission in DRIVE. Turn air conditioning OFF.
- 5) Adjust slotted idle bypass screw to obtain idle speed of 600 RPM.
- 6) Turn off engine. Disconnect tachometer. Reconnect all disconnected hoses.

## THROTTLE POSITION SWITCH

To adjust, loosen two throttle position switch mounting screws just enough to permit rotation of switch. Hold throttle valve in idle position while performing the following: Turn throttle position switch carefully counterclockwise until end-stop has been reached. Tighten mounting screws. Release throttle valves and make sure that throttle valves close to throttle stop, if not, repeat procedure.

## TIGHTENING SPECIFICATIONS

Application	Ft. Lbs.
Throttle Linkage Bracket-to-Manifold .....	30
Fuel Pump Bracket-to-Frame .....	20
Throttle Body Mounting Screws .....	15
Injector Hold Down Bracket .....	30
Flare Nuts on Fuel Rail .....	25
Sensors .....	15
Fuel Pump Mounting Screws .....	55 INCH Lbs.