

1980 Rochester Carburetors

ROCHESTER E4MC, E4ME, M4MC & M4ME 4-BARREL

CARBURETOR APPLICATION

GENERAL MOTORS
(BUICK, CADILLAC, CHEVROLET,
GMC CABALLERO, OLDSMOBILE & PONTIAC)

Application	Rochester Carb. No.	
	Man. Trans.	Auto. Trans.
231" V6		
Federal (M4ME)		17080240, 242, 243
California (E4ME)		17080540, 542, 543
252" V6		
Federal (M4ME)		
With A/C		17080244
301" V8		
Federal (M4ME)		17080270, 272, 274
305" V8		
Federal (M4ME)		
Without A/C	17080207	17080202
With A/C	17080207	17080204
California (E4ME)		
Without A/C		17080502
With A/C		17080504
307" V8		
Federal (M4MC)		
Without A/C		17080250
With A/C		17080253, 259
350" V8		
Federal (M4MC)		
With A/C		17080259
Federal (M4ME)		
Without A/C	17080207	17080202
With A/C	17080207	17080204, 228
California (E4MC)		
With A/C		17080553, 554
368" V8		
Federal (M4ME)		
With A/C		17080230
California (E4ME)		
With A/C		17080530

CARBURETOR IDENTIFICATION

The Rochester carburetor number is stamped on vertical section of float bowl, near the secondary throttle. If float bowl is replaced, follow manufacturer's instructions contained in service package to ensure part number is transferred to new float bowl.

DESCRIPTION

The M4MC and M4ME carburetor is a 2 stage type downdraft design. The primary side has a triple venturi system. The secondary side is composed of 2 large throttle bores using the air valve principle, in which fuel is metered in direct proportion to the amount of air passing through the secondary throttle bores. A baffle is attached to the secondary side of the air horn above the main well bleed tubes. This deflects incoming air to improve secondary nozzle operation on heavy acceleration. The M4MC models use a float bowl mounted heated air type choke assembly. The M4ME models use a float bowl mounted electrically actuated type choke assembly. Both models may be equipped with both primary (front) and secondary (rear) choke vacuum break diaphragms.

The E4ME and E4MC are basically the same type carburetors, except they are used in conjunction with the Computer Controlled Catalytic Converter System (C-4). The carburetors are equipped with an electrically actuated mixture control solenoid mounted in the float bowl. Fuel metering is controlled by stepped metering rods that operate in removable jets.

The metering rods are positioned by a plunger in the mixture control solenoid. The solenoid is actuated by an electrical signal from the Electronic Control Module (ECM). The ECM receives a signal from an oxygen sensor mounted in the exhaust manifold. The ECM will signal the mixture control solenoid to either lower the metering rods to lean the mixture or raise the rods to richen the mixture. Air metering to the idle system is controlled at the same time by an idle air bleed valve located in the air horn. This valve follows movement of the mixture control solenoid.

A Throttle Position Sensor (TPS) is used to signal the ECM of throttle position changes as they occur. When throttle position is changed, a tang on the pump lever moves TPS plunger. This signals the ECM to hold the last known air/fuel ratio to aid in throttle response. Under full throttle conditions, the TPS signals the ECM to run solenoid at full rich.

ADJUSTMENTS

HOT (SLOW) IDLE RPM

See appropriate article in *TUNE-UP SERVICE PROCEDURES*.

IDLE MIXTURE

See appropriate article in *TUNE-UP SERVICE PROCEDURES*.

COLD (FAST) IDLE RPM

See appropriate article in *TUNE-UP SERVICE PROCEDURES*.

IDLE AIR BLEED VALVE (E4ME & E4MC ONLY)

See appropriate article in *TUNE-UP SERVICE PROCEDURES*.

► ANGLE GAUGE ADJUSTMENT TOOL

Manufacturer recommends that some carburetor adjustments be performed using a choke valve angle gauge (Kent-Moore tool no. J-26701). While preparations and actual adjustments may vary with individual adjustment, the procedure for using the angle gauge to check the choke valve angle remains the same. Use the following procedure to perform adjustments requiring the use of the choke valve angle gauge.

- 1) Rotate degree scale on angle gauge so that 0° mark is opposite pointer.
- 2) With choke valve closed, place angle gauge magnet squarely on choke valve.
- 3) Rotate leveling bubble on angle gauge until it is centered.
- 4) Rotate degree scale until specified degree mark is opposite pointer.

ROCHESTER E4MC, E4ME, M4MC & M4ME 4-BARREL (Cont.)

5) Now perform individual adjustment preparations as outlined in the following carburetor adjustments requiring angle gauge. If bubble is centered, adjustment is correct. If not, adjust carburetor as outlined.

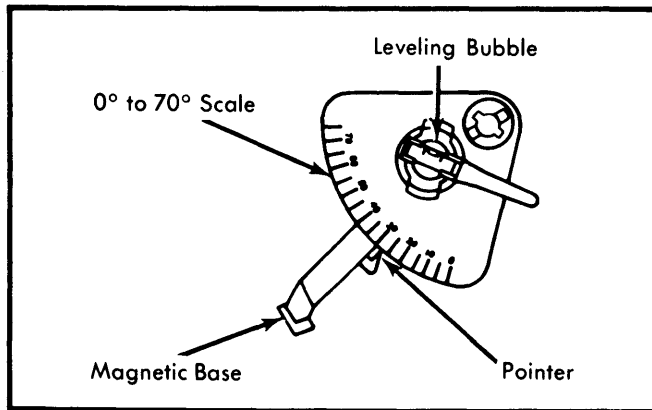

Fig. 1 Choke Valve Angle Gauge

FLOAT LEVEL

1) Remove air horn. Remove gasket from main body casting. Hold float retainer firmly in place. See Fig. 2.

2) Apply light finger pressure to push float gently against needle. Measure distance with "T" scale from top of casting to top of float. Gauging point should be $\frac{3}{16}$ " back from end of float at toe.

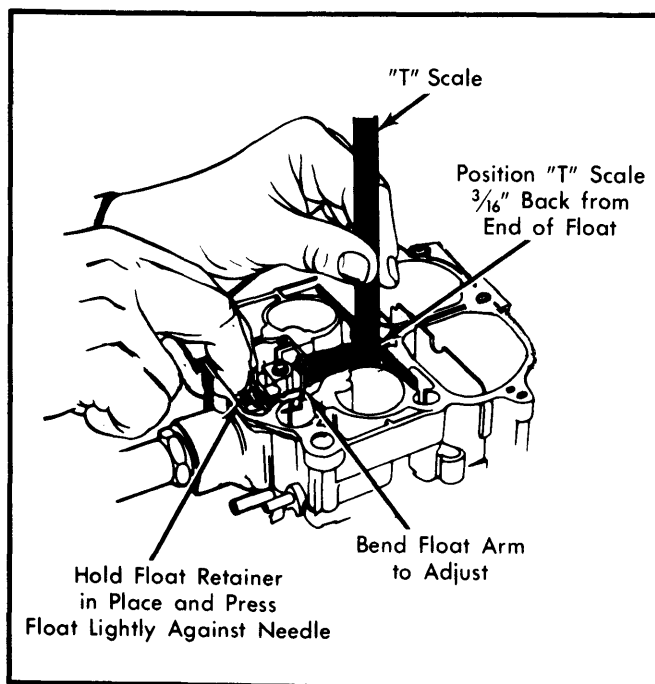

Fig. 2 Adjusting Float Level

3) If adjustment is needed, REMOVE float from main body of carburetor. Bend float arm up or down. Install float and recheck float level.

4) Be sure to check float alignment after adjusting operation. Install new gasket and reinstall air horn.

ACCELERATOR PUMP ROD

1) Close throttle valves completely. Make sure fast idle cam follower is off fast idle cam steps. Bend secondary throttle closing tang to make sure primary throttle valves are fully closed. Readjust after accelerator pump adjustment. See Fig. 3.

2) Make sure accelerator pump rod is in specified hole (inner or outer) in accelerator pump lever.

3) Using a "T" scale, measure specified distance from top of choke valve wall (next to vent stack) to top of pump stem.

4) To adjust, bend accelerator pump lever at point shown.

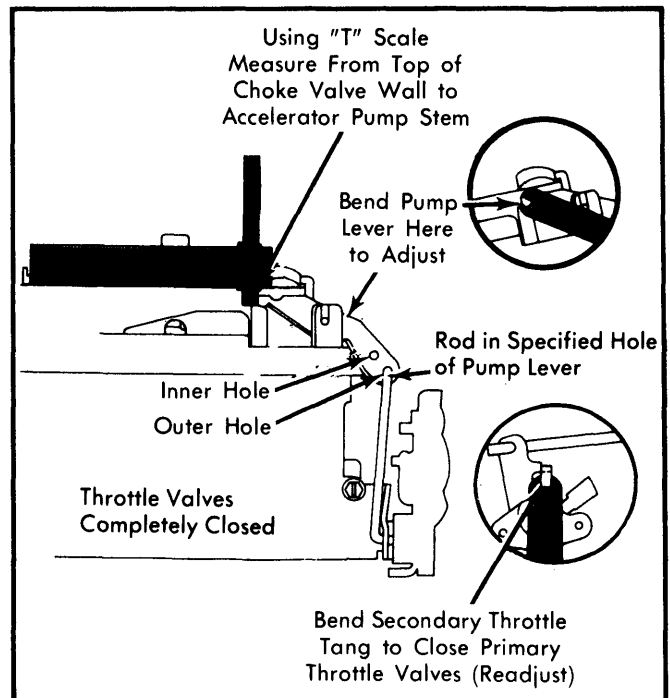

Fig. 3 Adjusting Accelerator Pump

CHOKE COIL LEVER

NOTE — Choke coil cover uses rivets in place of retaining screws. If necessary to remove choke coil cover, refer to Disassembly and Reassembly procedures in this Section.

1) Loosen (3) screws retaining thermostatic cover and coil assembly and remove cover from housing. Press upward on thermostatic coil tang (counterclockwise) until choke valve is closed. See Fig. 4.

ROCHESTER E4MC, E4ME, M4MC & M4ME 4-BARREL (Cont.)

2) Make sure choke rod is in bottom of slot in choke lever. Insert a drill or pin gauge of specified size into hole in choke housing casting.

3) Lower edge of lever in choke housing should just touch drill or pin gauge. Bend choke rod at point shown to adjust. Install choke coil and cover. Adjust automatic choke.

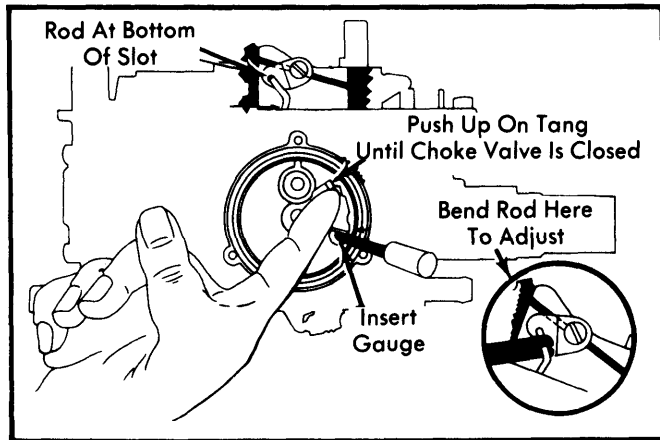

Fig. 4 Adjusting Choke Coil Lever

FAST IDLE ADJUSTMENT (BENCH SETTING)

NOTE — This is a preliminary adjustment only. It is required to ensure that other adjustments are made with fast idle speed approximately correct. Final Cold (Fast) Idle Speed adjustment must be made with carburetor installed and engine running. See appropriate article in TUNE-UP Section.

1) Place fast idle speed cam follower on high step of fast idle cam. Back off fast idle speed screw until throttle valves are completely closed.

2) Now turn fast idle speed screw in until it just touches lever, then turn an additional 2 turns in.

CHOKE ROD (FAST IDLE CAM)

NOTE — Fast idle adjustment (bench setting) and choke coil lever must be adjusted first. This adjustment is performed using choke angle gauge, see procedure at beginning of adjustment.

1) Place fast idle speed cam follower on second step of fast idle cam against shoulder of highest step. See Fig. 5.

2) Close choke by pushing up on choke coil lever or vacuum break lever tang. Hold choke closed with a rubber band.

3) Bubble on choke angle gauge should be centered with specified angle mark opposite pointer.

4) To adjust, bend tang on fast idle cam until bubble of choke valve angle gauge is centered.

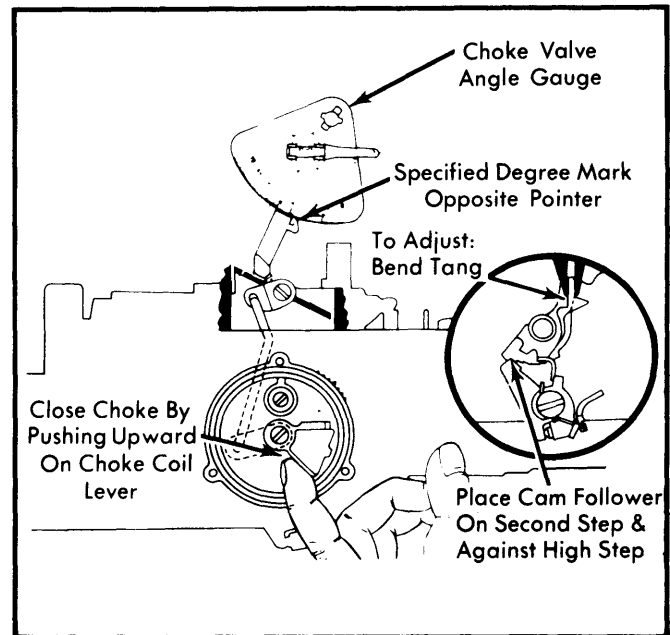

Fig. 5 Adjusting Choke Rod
(Fast Idle Cam)

AIR VALVE ROD — FRONT

1) Using an outside vacuum source, seat primary (front) choke vacuum break diaphragm. Plug purge bleed hole (if equipped) with masking tape. Hole is found in end of diaphragm. See Fig. 6.

2) Make sure air valve is completely closed. Measure clearance between rod and end of slot in lever. Clearance can be checked using a specified drill or pin gauge.

3) Bend rod at point shown to adjust clearance in slot. Remove tape and reconnect vacuum hose to diaphragm.

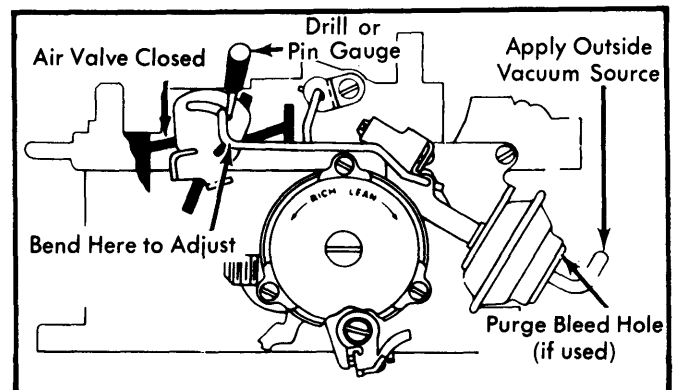

Fig. 6 Adjusting Air Valve Rod — Front

AIR VALVE ROD — REAR

1) Using an outside vacuum source, seat secondary (rear) choke vacuum break diaphragm. See Fig. 7.

ROCHESTER E4MC, E4ME, M4MC & M4ME 4-BARREL (Cont.)

2) Make sure air valve is completely closed. Measure clearance between rod and end of slot in lever. Clearance can be checked using a specified drill or pin gauge.

3) Bend rod at point shown to adjust clearance in slot. Reconnect vacuum hose to diaphragm.

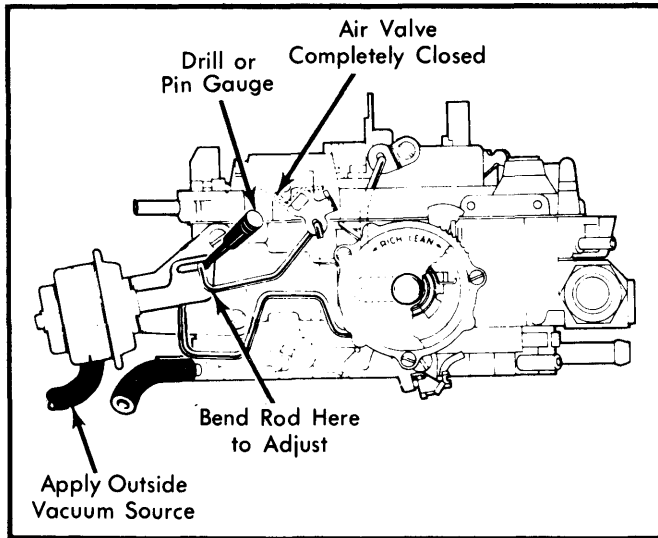

Fig. 7 Adjusting Air Valve Rod - Rear

PRIMARY (FRONT) VACUUM BREAK

NOTE - This adjustment is performed using the choke angle gauge, see procedure at beginning of Adjustments.

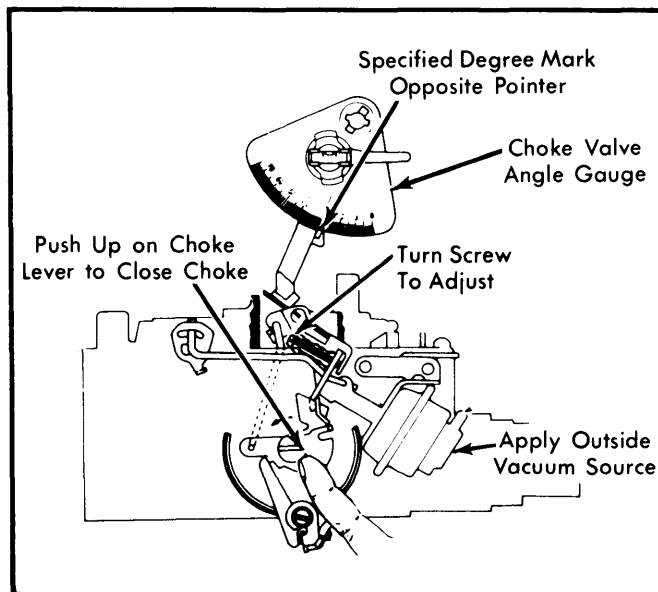

Fig. 8 Adjusting Primary (Front) Vacuum Break

1) Using an outside vacuum source of at least 15 in. Hg, seat primary (front) vacuum break diaphragm. See Fig. 8.

NOTE - Plug purge bleed hole (if equipped) with masking tape. Hole is found in end of diaphragm.

2) Close choke by pushing up on choke coil lever or vacuum break lever tang. Hold choke closed with a rubber band.

3) Bubble on angle gauge should be centered with specified degree mark opposite pointer.

4) To adjust, turn vacuum break adjustment screw until bubble of choke valve angle gauge is centered.

SECONDARY (REAR) VACUUM BREAK

NOTE - This adjustment is performed using the choke valve angle gauge, see procedure at beginning of Adjustments.

1) Using an outside vacuum source of at least 15 in. Hg, seat secondary (rear) choke vacuum break diaphragm. See Fig. 9.

2) Close choke valve by pushing up on choke coil lever or vacuum break lever tang. Make sure bucking spring on diaphragm plunger (if equipped) is compressed and seated.

3) Bubble on choke valve angle gauge should be centered with specified degree mark opposite pointer.

4) To adjust, turn rear vacuum break adjustment screw until bubble of choke valve angle gauge is centered.

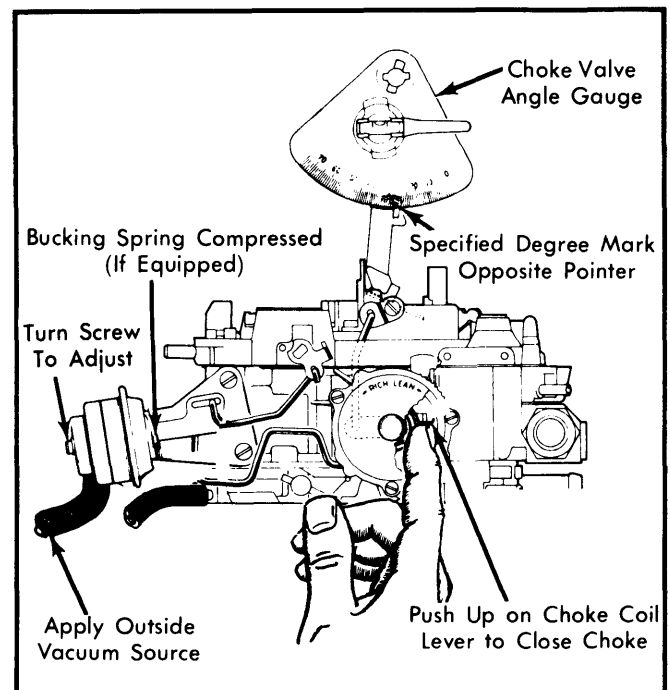

Fig. 9 Adjusting Secondary (Rear) Vacuum Break

ROCHESTER E4MC, E4ME, M4MC & M4ME 4-BARREL (Cont.)

AIR VALVE SPRING

- 1) Use hex wrench to loosen lock screw. Turn tension adjusting screw counterclockwise until air valve opens part way.
- 2) Hold air valve closed. Turn tension adjusting screw clockwise specified number after spring contacts pin.
- 3) Hold adjusting screw and tighten lock screw.

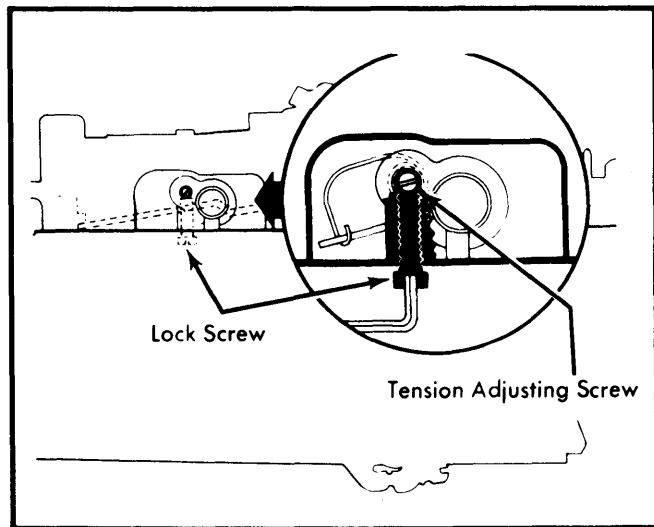

Fig. 10 Adjusting Air Valve Spring

AUTOMATIC CHOKE

NOTE — Choke coil cover uses rivets in place of retaining screws. If necessary to remove choke coil cover, refer to Disassembly and Reassembly procedures in this Section.

- 1) Loosen 3 choke cover retaining screws. Position fast idle cam follower on high step of fast idle cam.
- 2) Rotate cover in specified direction to align reference mark on cover with specified graduation in housing. Tighten cover screws.

CHOKE UNLOADER

NOTE — This adjustment is performed using the choke valve angle gauge. See procedure at beginning of Adjustments.

- 1) Adjust automatic choke as previously outlined. Hold throttle valves wide open. See Fig. 11.
- 2) If engine is warm, close choke valve by pushing up on vacuum break lever tang. Hold in position with a rubber band.
- 3) Bubble on choke valve angle gauge should be centered with specified degree mark opposite pointer.
- 4) To adjust, bend choke unloader tang on throttle lever until bubble of choke valve angle gauge is centered.

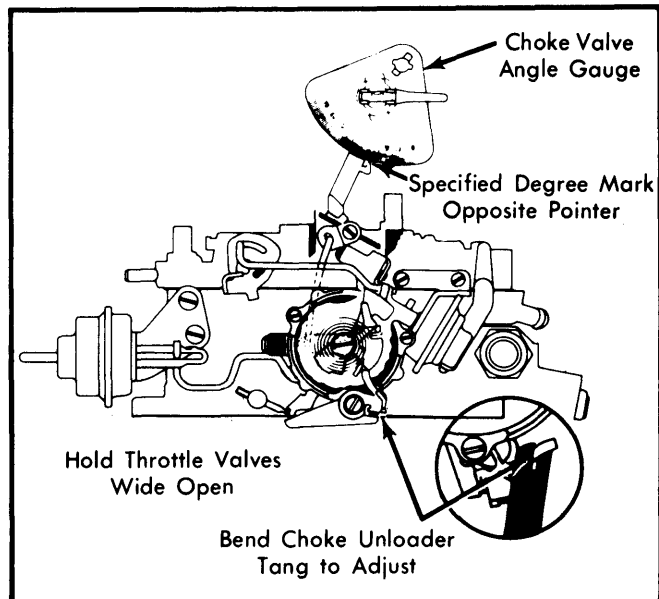

Fig. 11 Adjusting Choke Unloader

SECONDARY THROTTLE VALVE LOCKOUT

Lockout Lever Side Clearance — 1) Hold choke valve and throttle valves closed completely. See Fig. 12.

2) Measure secondary throttle valve lockout specified side clearance between pin and lockout lever.

3) Specified clearance is .015". To adjust, bend pin.

Lockout Lever Opening Clearance — 1) Push down on tail of fast idle cam and open choke valve completely.

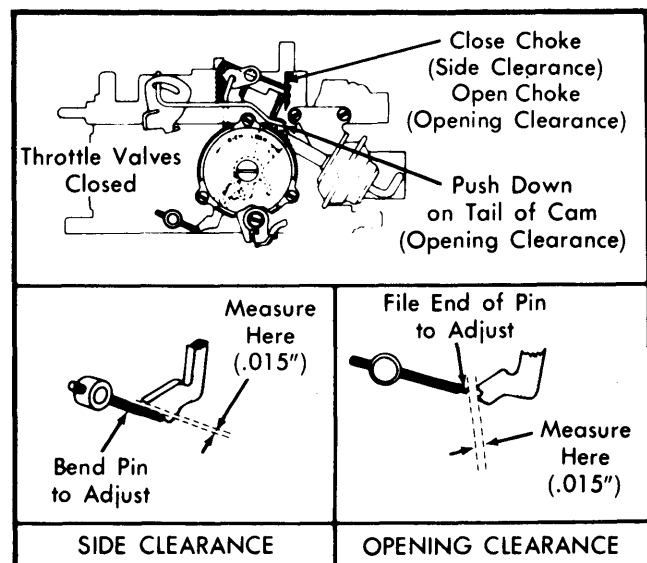

Fig. 12 Adjusting Secondary Throttle Valve Lockout

ROCHESTER E4MC, E4ME, M4MC & M4ME 4-BARREL (Cont.)

- 2) Measure secondary throttle valve lockout specified opening clearance between end of pin and toe of lockout lever.
- 3) Specified clearance is .015". To adjust, file end of lockout pin. Make sure all burrs are removed.

SECONDARY CLOSING LINKAGE

- 1) Engine idle speed must be correctly adjusted. Hold choke valve wide open and make sure fast idle cam follower is off fast idle cam steps. See Fig. 13.
- 2) Make sure secondary closing lever is against tang. Measure specified clearance between secondary throttle link and slot in secondary throttle lever.
- 3) Specified clearance is .020". To adjust bend tang.

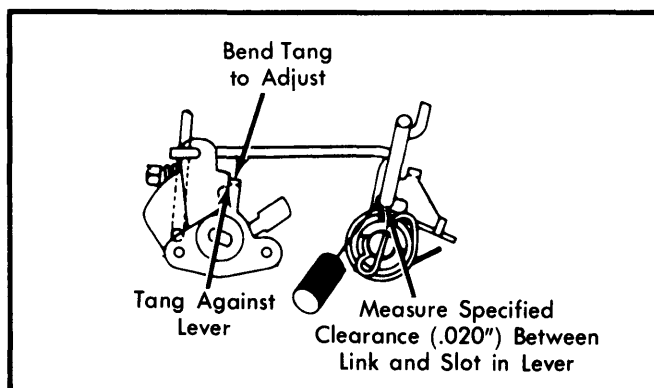

Fig. 13 Adjusting Secondary Throttle Closing Linkage

SECONDARY OPENING LINKAGE

- 1) Open primary throttle valves until secondary throttle link just contacts tang on secondary throttle lever. See Fig. 14.
- 2) Link should be centered in slot of secondary throttle lever. To adjust, bend tang on secondary throttle lever.

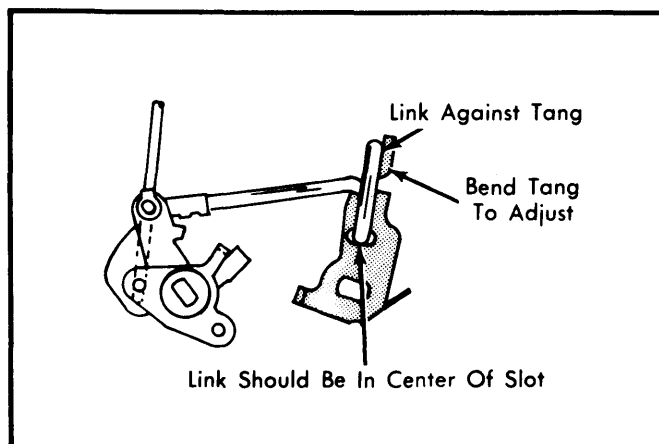

Fig. 14 Measuring Secondary Throttle Opening Linkage

MIXTURE CONTROL SOLENOID

- 1) Solenoid operation can be checked on vehicle using external float level gauge tool (J-9789-130). Some material must be removed from the side of the tool to allow for clearance in air horn.
- 2) Remove air cleaner and gasket. Insert gauge in "D" shaped vent hole in casting next to Idle Air Bleed Valve plug. Make sure gauge moves freely in hole.
- 3) Press down on gauge and release. With gauge released (solenoid up position), read inch mark on gauge that lines up with top of air horn casting and record reading.
- 4) Lightly press down on gauge until it bottoms (solenoid down position). Read inch mark that lines up with air horn casting.
- 5) Subtract solenoid up position from solenoid down position. Difference is total solenoid travel. Travel should not exceed or be less than 1/16" to 1/8".
- 6) To adjust, remove air horn. Turn mixture control solenoid screw clockwise. Record number of turns required to lightly bottom screw in float bowl.
- 7) If number of turns is greater than 2 1/2 or less than 1 1/2, solenoid travel is incorrect and solenoid mixture control solenoid screw must be adjusted. Proceed to step 8). If number of turns was 1 1/2 to 2 1/2, solenoid stop screw must be adjusted. Proceed to step 9).

8) With screw bottomed, turn screw counterclockwise until screw is backed exactly 2 turns off seat.

9) Turn air horn upside down. Using a wrench, remove solenoid stop screw. Drive out small plug located between 2 "D" shaped vent holes. This will allow access to stop screw when air horn is installed.

10) Reinstall solenoid stop screw and spring. Lightly bottom screw in air horn. Install air horn, with a new gasket, onto main body.

11) Install external gauge tool in "D" shaped vent hole. Adjust stop screw until total solenoid travel is 1/16" to 1/8".

OVERHAUL

DISASSEMBLY

NOTE — Before performing any service on carburetor, it is essential that carburetor be placed on a holding fixture (J-8328) to prevent damage to throttle valves.

Idle Stop Solenoid — If equipped with idle stop solenoid, remove screws securing solenoid and bracket to float bowl and remove assembly.

ROCHESTER E4MC, E4ME, M4MC & M4ME 4-BARREL (Cont.)

Air Horn Removal – 1) Remove upper choke lever from end of choke shaft by removing retaining screw. Then rotate upper choke lever to remove choke rod from slot in lever. Remove choke rod from lower lever inside float bowl casting.

NOTE – Remove rod by holding lower lever outward with small screwdriver and twisting rod counterclockwise.

2) Remove vacuum hose from front vacuum break unit. Remove secondary metering rods by removing the small screw in top of metering rod hanger. Lift upward on metering rod hanger until secondary metering rods are completely out of air horn. Metering rods may be disassembled from hanger by rotating ends out of holes in end of hanger.

3) Drive pump lever pivot pin inward until pump lever can be removed, then disconnect pump rod from pump lever. Remove air horn-to-float bowl attaching screws. Remove secondary air baffle deflector from beneath center 2 air horn screws. Remove air horn from float bowl by lifting straight up.

4) Remove front vacuum break attaching screws and front vacuum break diaphragm. Disconnect diaphragm from air valve dashpot rod and remove dashpot rod from air valve lever. On E4ME and E4MC models remove TPS plunger by pushing up through seal in air horn. Remove seal retainer and seal. Remove accelerator pump plunger seal from air horn.

5) No further disassembly of air horn is required unless choke valve or shaft is being replaced. If so, remove staking from choke valve screws before removal.

NOTE – E4ME and E4MC models with C-4 system are sensitive to air/fuel mixture adjustments. The solenoid stop screw and idle air bleed valve are preset at the factory. A plug is installed over the solenoid stop screw and a cover over the idle air bleed valve to prevent tampering. Do not remove these unless replacement or repair of stop screw, bleed valve or air horn is necessary.

6) If necessary to remove idle air bleed valve on E4ME models, align a .110" (No. 35) drill on rivet head retaining cover and drill only enough to remove rivet head. Repeat for remaining rivet and drive remaining rivet pieces out of air horn casting. Remove and discard cover.

7) Using a screwdriver that fully fits in slot in valve, turn valve counterclockwise to remove from air horn. Remove "O" rings from valve. New "O" rings are required for reassembly.

Float Bowl (E4ME & E4MC Models) – 1) Remove solenoid metering rod plunger by lifting straight up. Remove air horn-to-float bowl gasket. Remove pump plunger and return spring from pump well.

2) Push up from bottom on electrical connector and remove TPS and connector assembly from float bowl. Remove spring from TPS well. Remove rubber seal from mixture control solenoid. Remove plastic filler block from over float bowl.

3) Carefully remove each metering rod from metering jet. Make sure return spring is removed with each rod. Remove return spring by sliding it off metering rod.

4) Remove screw attaching solenoid connector to float bowl. Turn mixture control solenoid screw clockwise counting number of turns required to lightly seat in float bowl. Turn solenoid screw counterclockwise and remove from float bowl. Carefully lift connector and solenoid from float bowl.

NOTE – Do not remove plunger return spring or connector from solenoid body. Solenoid and connector are serviced as an assembly.

5) Remove plastic insert from solenoid connector cavity in float bowl. Remove solenoid screw tension spring (next to float hanger clip). Remove float assembly and needle valve by lifting straight up. Remove needle valve seat and gasket.

6) Remove large mixture control solenoid tension spring from boss on bottom of float bowl located between metering jets. Remove metering jets (if necessary).

7) Remove accelerator pump discharge check ball retainer and check ball. Remove accelerator pump well baffle (if necessary).

8) Remove rear vacuum break diaphragm and bracket. Rotate unit to remove vacuum break rod from slot in diaphragm plunger.

9) Align a .159" (No. 21) drill on choke cover retaining rivet and drill only enough to remove rivet head. Repeat for remaining 2 rivets. Remove choke cover and coil assembly. Remove choke housing retaining screw located inside choke housing. Slide complete choke assembly from float bowl.

10) Remove choke coil lever retaining screw from end of intermediate shaft. Remove thermostatic coil lever from flats on intermediate shaft and remove shaft. Fast idle cam can now be removed from intermediate choke shaft.

11) Remove fuel inlet nut, gasket and filter. Remove throttle body-to-float bowl attaching screws and throttle body.

Float Bowl (M4MC & M4ME) – 1) Remove air horn gasket by lifting tab gasket from beneath power piston hanger. Remove pump plunger and return spring from pump well.

2) Remove power piston and metering rods by depressing piston stem and allowing it to snap free. Repeat procedure until retainer is removed from casting. Remove power piston spring from well.

NOTE – Do not use pliers on metering rod hanger to remove power piston.

3) Disconnect tension spring from top of each metering rod. Rotate rods to remove from hanger. Note position of rods for reassembly. Remove plastic filler block from float bowl.

4) Remove float assembly and fuel inlet needle by lifting straight up on retaining clip. Remove needle valve and gasket. Remove aneroid cavity from float bowl. Remove main metering jets from float bowl.

NOTE – To complete disassembly of float bowl for M4MC and M4ME models, follow steps 7) through 11) in E4ME/E4MC float bowl disassembly procedures.

ROCHESTER E4MC, E4ME, M4MC & M4ME 4-BARREL (Cont.)

NOTE — If idle air bleed valve is not removed on E4ME/E4MC model carburetors, clean air horn in a low-volatile solvent only. DO NOT place in carburetor cleaner. Damage to "O" rings on idle air bleed valve will result.

Throttle Body — 1) Remove accelerator pump rod from throttle lever.

NOTE — It is not necessary to disassemble throttle body any further. Do not remove idle mixture screw plugs unless it is necessary to replace mixture screws or cleaning and air pressure fails to clean idle mixture passages. If necessary to remove, proceed as follows:

2) Invert throttle body and position on a holding fixture with manifold side up. Position a punch in between 2 locator points on manifold side of throttle body. There are 2 locator points adjacent to each mixture screw.

3) Using a hammer, drive punch against throttle body to break out portion of throttle body to gain access to idle mixture screw plugs. Drive out hardened steel plugs.

NOTE — Hardened steel plug will shatter. It is not necessary to remove plug completely. Remove just enough pieces to allow idle mixture adjusting tool (J-29030) to be used to remove mixture screws and springs. Idle mixture screw head has a "double-D" configuration and can also be removed using a piece of 7/32" copper tubing that has been partially flattened.

CLEANING & INSPECTION

- Use a regular carburetor cleaning solution. Soak components long enough to thoroughly clean all surfaces and passages of foreign matter.
- Remove any residue after cleaning by rinsing components in a suitable solvent.
- Do not soak any components containing rubber, leather or plastic.
- Blow out all passages with dry compressed air.

REASSEMBLY

NOTE — Use new gaskets and seals. Make sure that new gaskets fit correctly and that all holes and slots are punched through and correctly located.

Reassemble carburetor in reverse order of disassembly, noting the following:

1) The intermediate choke shaft lever and fast idle cam are assembled correctly when tang and lever are below fast idle cam.

2) When installing float and retaining pin, make sure open end of float retaining pin faces accelerator pump well and fuel inlet needle pull clip is over edge of flat on float arm. Do not hook clip into holes in float arm.

3) When installing mixture control solenoid on E4ME/E4MC models, make sure pin on end of solenoid aligns with hole in raised boss at bottom of float bowl.

4) On E4ME/E4MC models, turn solenoid mixture screw clockwise until it is lightly bottomed in float bowl. With screw bottomed, back screw out of float bowl exactly 2 turns.

NOTE — Do not force solenoid mixture screw to bottom. Damage to screw or seat will result.

5) When installing idle air bleed valve (if removed) on E4ME/E4MC models, turn valve clockwise until it is lightly seated. Then back screw out 2 turns. Final adjustment must be made on vehicle.

NOTE — If choke coil cover was removed, it will be necessary to install self-tapping screws (supplied in service kit) to replace retainer rivets. Before installing cover, start self-tapping screws into choke housing, making sure they start easily and are properly aligned. Remove screws and proceed as follows:

6) Place fast idle screw on high step of fast idle cam. Install choke coil cover, aligning notch in cover with tab on cover retainer (supplied in service kit). Install retainer with tab into screw hole in housing nearest front of carburetor. Install remaining screws and retainers and tighten securely.

7) Install air horn screws and tighten evenly, securely, and in sequence shown in Fig. 15.

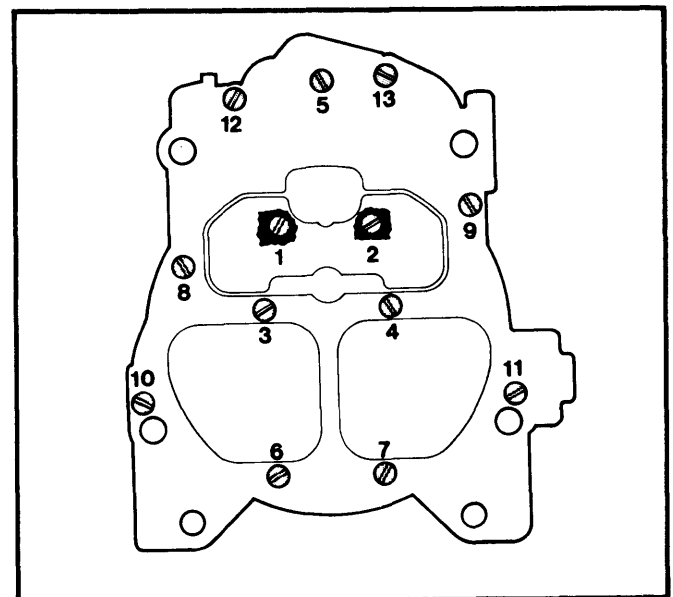

Fig. 15 Air Horn Screw Tightening Sequence

1980 Rochester Carburetors

2-81

ROCHESTER E4MC, E4ME, M4MC & M4ME 4-BARREL (Cont.)

CARBURETOR ADJUSTMENT SPECIFICATIONS										
Application	Float Level Setting	Accelerator Pump		Choke Coil Lever Setting	Choke Rod Setting	Air Valve Rod Setting ^①	Vacuum Break		Air Valve Spring Setting ^②	Choke Unloader Setting
		Stem Setting	Hole Setting				Primary Setting	Secondary Setting		
M4MC										
17080250	13/32"	9/32"	Inner	.120"	17°	.025"	26°	34°	1/2	35°
17080253	13/32"	9/32"	Inner	.120"	17°	.025"	26°	34°	1/2	35°
17080259	13/32"	9/32"	Inner	.120"	17°	.025"	26°	34°	1/2	35°
M4ME										
17080202	7/16"	1/4"	Inner	.120"	20°	.025"	27°	7/8	38°
17080204	7/16"	1/4"	Inner	.120"	20°	.025"	27°	7/8	38°
17080207	7/16"	1/4"	Inner	.120"	20°	.025"	27°	7/8	38°
17080228	7/16"	9/32"	Inner	.120"	20°	.025"	30°	1	38°
17080230	7/16"	9/32"	Inner	.120"	16°	.025"	26°	24°	1/2	35°
17080240	3/16"	9/32"	Inner	.120"	14.5°	.025"	16°	16°	9/16	30°
17080242	13/32"	9/32"	Inner	.120"	14.5°	.025"	15°	18°	9/16	35°
17080243	3/16"	9/32"	Inner	.120"	14.5°	.025"	16°	16°	9/16	30°
17080244	5/16"	9/32"	Inner	.120"	24.5°	.025"	18°	14°	5/8	38°
17080270	15/32"	3/8"	Outer	.120"	14.5°	.025"	26°	34°	5/8	35°
17080272	15/32"	3/8"	Outer	.120"	14.5°	.025"	23°	29.5°	5/8	33°
17080274	15/32"	5/32"	Outer	.120"	16°	.025"	20°	28°	5/8	33°
E4MC										
17080553	15/32"	9/32"120"	17°	.025"	25°	35°	1/2	35°
17080554	15/32"	9/32"120"	17°	.025"	25°	34°	1/2	35°
E4ME										
17080502	1/2"120"	20°	.025"	24°	30°	9/16	38°
17080504	1/2"120"	20°	.025"	24°	30°	9/16	38°
17080530	17/32"	9/32"120"	16°	.025"	25°	55°	1/2	40°
17080540	3/8"120"	14.5°	.025"	19°	23°	9/16	38°
17080542	3/8"120"	14.5°	.025"	19°	13°	9/16	38°
17080543	3/8"120"	14.5°	.025"	19°	23°	9/16	38°

- ① - Setting is for both Front and Rear Air Valve Rod Adjustments.
 ② - Specification is amount of turns.