

## ROCHESTER MODELS 2SE & E2SE 2-BARREL

### CARBURETOR APPLICATION

#### AMERICAN MOTORS

Application	AMC Carb. No.
151" 4 Cylinder Man. Trans.	
Federal (2SE)	
Without A/C .....	17080681
With A/C .....	17080683
California (E2SE) .....	17080781
151" 4 Cylinder Auto. Trans.	
Federal (2SE)	
Without A/C .....	17080686
With A/C .....	17080688
California (E2SE) .....	17080782

#### GENERAL MOTORS

Application	Rochester Carb. No.
151" 4 Cylinder Man. Trans.	
Federal (2SE)	
Without A/C .....	17059615, 619, 623 & 17080675
With A/C .....	17059617, 621, 625 & 17080677
California (E2SE)	
Without A/C .....	17059715, 721, 775
With A/C .....	17059717, 723, 777
151" 4 Cylinder Auto. Trans.	
Federal (2SE)	
Without A/C .....	17059614, 618, 622 & 17080674
With A/C .....	17059616, 620, 624 & 17080676
California (E2SE)	
Without A/C .....	17059714, 718, 722, 774
With A/C .....	17059716, 720, 724, 776
173" V6 Man. Trans.	
Federal (2SE)	
Without A/C .....	17059651, 665
With A/C .....	17059653
California (E2SE) .....	17059763
173" V6 Auto. Trans.	
Federal (2SE)	
Without A/C .....	17059650, 660, 664
With A/C .....	17059652, 662
California (E2SE)	
Without A/C .....	17059760
With A/C .....	17059762, 768

### CARBURETOR IDENTIFICATION

The Rochester 2SE and E2SE carburetor numbers are stamped vertically on the float bowl next to the vacuum tube. If float bowl is replaced, follow manufacturer's instructions contained in service package, so that part number is transferred to new float bowl.

### DESCRIPTION

The Rochester models 2SE & E2SE are 2-stage, 2-barrel downdraft carburetors. The primary stage consists of a triple venturi with a 35 mm bore. The secondary stage has a 46 mm bore and is equipped with an air valve with a single tapered metering rod. Both are equipped with integral electronically activated chokes, a choke vacuum break diaphragm and an idle speed solenoid.

The E2SE model is used in conjunction with the Computer Controlled Catalytic Converter System (C-4). The carburetor is

equipped with an electrically actuated mixture control solenoid mounted in the float bowl. Fuel metering is controlled by the mixture control solenoid plunger opening and closing the fuel passage to the main metering jet.

This opening and closing action causes a variable restriction of fuel to the main metering circuit, changing air/fuel ratio. Also, air metered to the idle system is controlled by the movement of the mixture control solenoid plunger.

The solenoid is activated by an electronic signal from the Electronic Control Module (ECM). The ECM responds to a signal from the oxygen sensor in the exhaust, then energizes the solenoid to move the plunger down to a lean position or de-energizes solenoid to move plunger up to a rich position. Air metered (by solenoid plunger) to idle system is controlled by an idle air bleed valve located in the air horn. This valve follows movement of the mixture control solenoid.

On E2SE models used on V6 engines, a Throttle Position Sensor (TPS) is used to signal the ECM of throttle position changes as they occur. When throttle position is changed, a tang on the pump lever moves TPS plunger. This signals the ECM to hold the last known air/fuel ratio to aid in throttle response.

### ADJUSTMENT

#### HOT (SLOW) IDLE RPM

See appropriate article in TUNE-UP SERVICE PROCEDURES.

#### COLD (FAST) IDLE RPM

See appropriate article in TUNE-UP SERVICE PROCEDURES.

#### IDLE MIXTURE

See appropriate article in TUNE-UP SERVICE PROCEDURES.

#### IDLE AIR BLEED VALVE (E2SE ONLY)

See appropriate article in TUNE-UP SERVICE PROCEDURES.

#### ▶ ANGLE GAUGE ADJUSTMENT TOOL

Manufacturer recommends that some carburetor adjustments be performed using a choke valve angle gauge (Kent-Moore tool no. J-26701). While preparations and actual adjustments may vary with each individual adjustment, the procedure for using the angle gauge to check the choke valve angle remains the same. Use the following procedure to perform adjustments requiring the use of the choke angle gauge.

- 1) Rotate degree scale on angle gauge so that 0° mark is opposite pointer.
- 2) With choke valve closed, place angle gauge magnet squarely on choke valve.
- 3) Rotate leveling bubble on angle gauge until it is centered.
- 4) Rotate degree scale until specified degree mark is opposite pointer.
- 5) Now perform individual adjustment preparations as outlined in the following carburetor adjustments requiring angle gauge. If bubble is centered, adjustment is correct. If not, adjust carburetor as outlined.

# 1980 Rochester Carburetors

## ROCHESTER MODELS 2SE & E2SE 2-BARREL (Cont.)

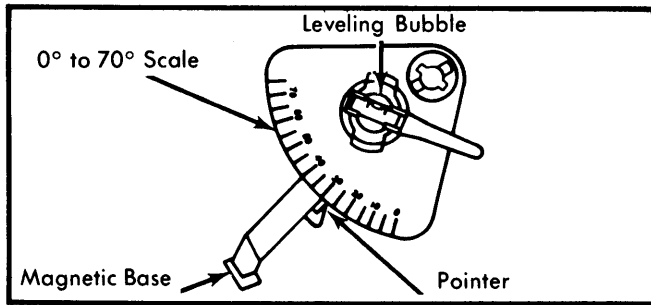

Fig. 1 Choke Valve Angle Gauge

### FLOAT LEVEL

- 1) Remove air horn and gasket from float bowl. Hold float retainer firmly down while pushing float down against needle. See Fig. 2.
- 2) Position a "T" scale over toe of float at point furthest away from float hinge. Measure distance from float bowl casting to float.
- 3) To adjust, remove float and bend float arm. Check to make sure float is correctly aligned after adjustment.

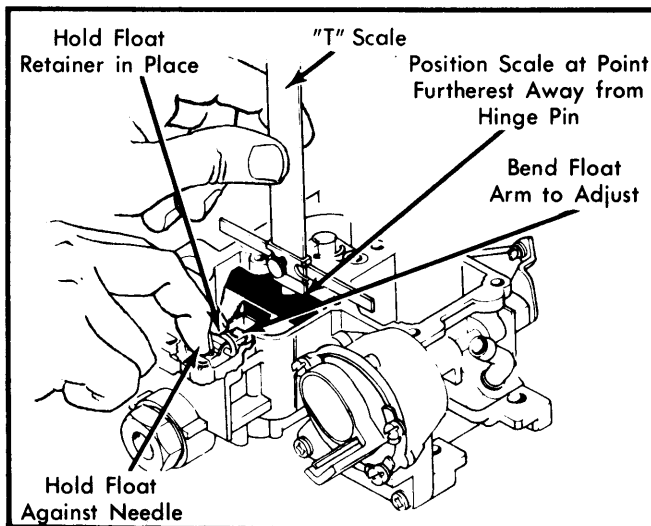

Fig. 2 Adjusting Float Level

### ACCELERATOR PUMP

**NOTE** — Accelerator pump adjustment should not be changed from original factory setting. Adjustment should be made only if specified setting is changed. Pump lever is manufactured from hardened steel. It is difficult to bend if adjustment is required. However, pump arm should not be removed to make adjustment unless absolutely necessary.

- 1) Close throttle valves completely. Make sure fast idle speed screw is off fast idle cam. See Fig. 3.
- 2) Using a "T" scale, measure accelerator pump specified distance from cast surface of air horn to top of pump stem.
- 3) To adjust, remove pump lever screw and washer. Remove pump lever by rotating lever and removing from pump rod. Secure lever in a vise and bend end of lever at small segment.

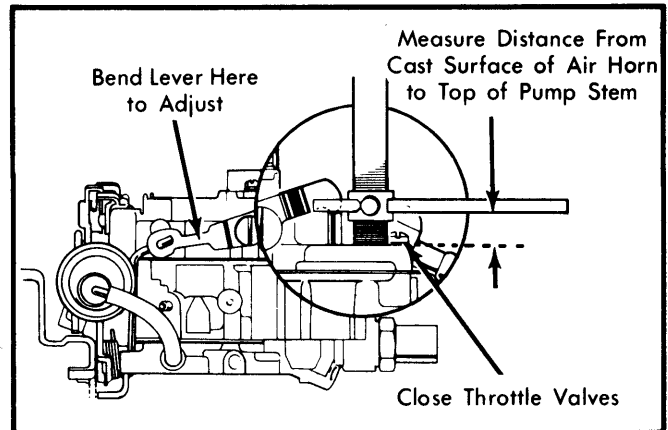

Fig. 3 Adjusting Accelerator Pump

- 4) Install pump lever and tighten screw. Recheck specified distance. Open and close throttle and check for freedom of movement.

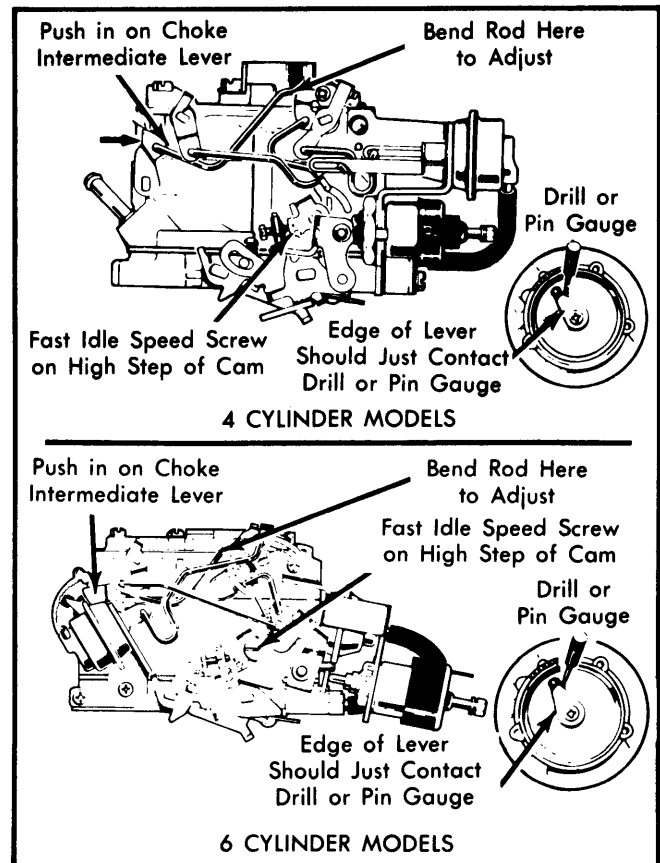

Fig. 4 Adjusting Choke Coil Lever

### CHOKE COIL LEVER

**NOTE** — Choke coil cover is retained on housing with rivets to prevent tampering with factory adjustment. If necessary to remove cover, refer to Disassembly and Reassembly procedures in this Section.

- 1) Remove choke thermostatic cover from choke housing. Place fast idle speed screw on high step of fast idle cam. See Fig. 4.
- 2) Push in on intermediate choke lever until choke valve is fully closed.

## ROCHESTER MODELS 2SE & E2SE 2-BARREL (Cont.)

3) Insert a specified drill or pin gauge in hole provided in choke housing. Choke lever inside housing should just touch drill or pin gauge.

4) To adjust, bend intermediate choke rod at point shown in illustration. Reinstall choke cover and adjust.

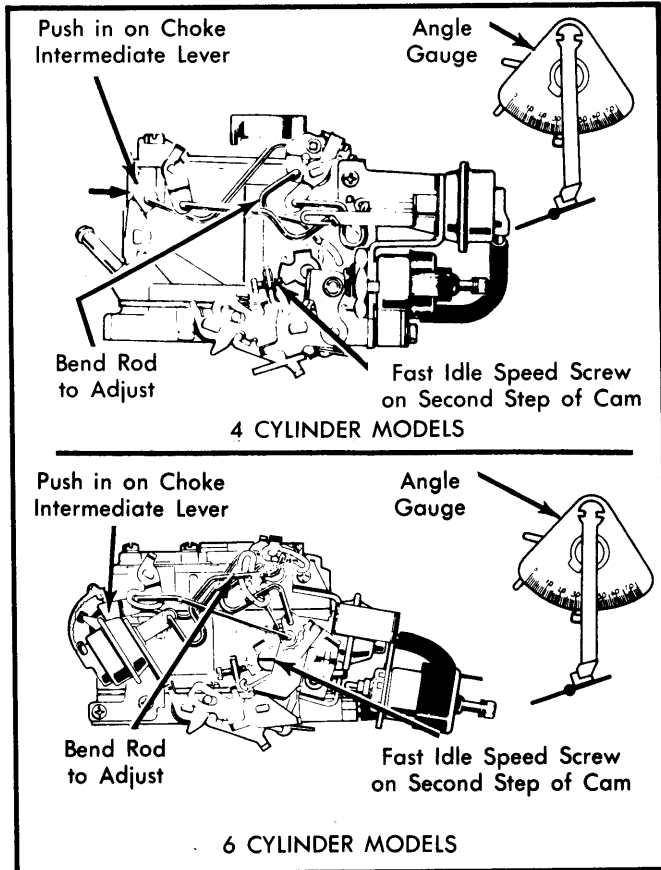

**Fig. 5 Adjusting Choke Rod (Fast Idle Cam)**

### CHOKE ROD (FAST IDLE CAM)

**NOTE** — Choke coil lever adjustment must be correct first. This adjustment is made using choke angle gauge. See angle gauge procedure at beginning of Adjustments.

1) Place fast idle speed screw on second step of fast idle cam against shoulder of highest step. See Fig. 5.

2) Close choke valve by pushing on intermediate choke lever. Push vacuum break lever toward open choke until lever is against rear tang on choke lever.

3) Bubble on choke angle gauge should be centered with specified degree mark opposite pointer.

4) To adjust, bend fast idle cam rod at point shown in illustration until bubble of choke valve angle gauge is centered.

### AIR VALVE ROD

**NOTE** — This adjustment is made by using the choke valve angle gauge. See procedure at beginning of Adjustments.

1) Using an outside vacuum source of at least 15 in. Hg, seat primary choke vacuum break diaphragm. Close air valve, mount and adjust angle gauge. See Fig. 6.

2) Apply light opening pressure to air valve shaft. Set to specified angle by bending air valve rod at a point near its connection to primary vacuum break (models equipped with primary vacuum break only) or at a point near its connection to air valve lever (models equipped with primary and secondary vacuum breaks).

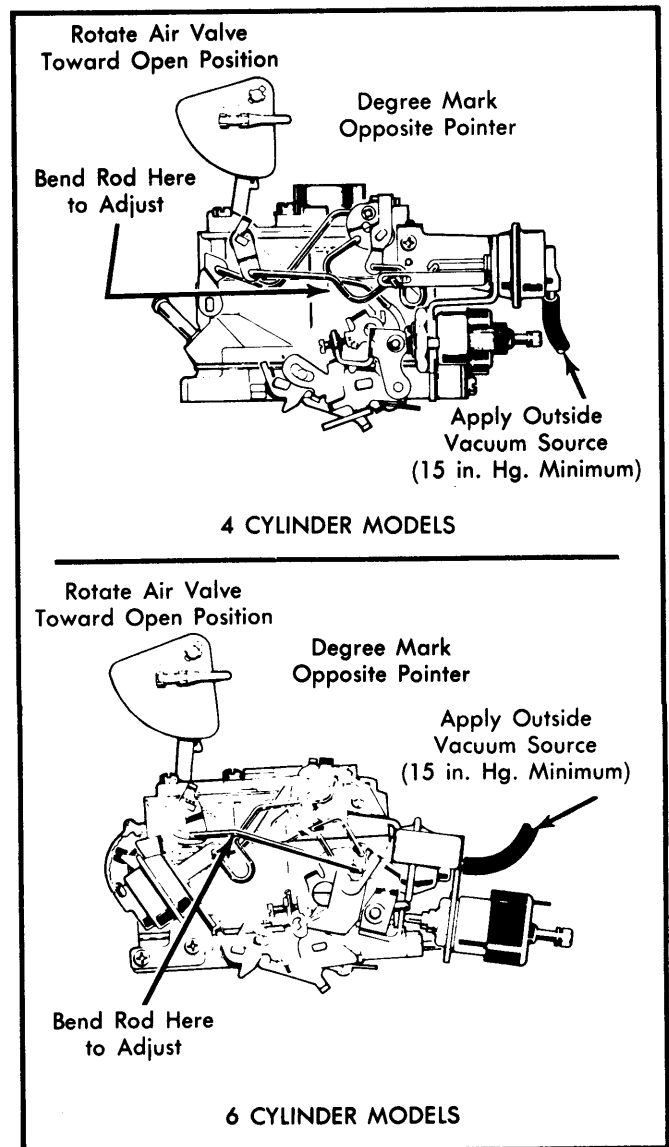

**Fig. 6 Adjusting Air Valve Rod**

### PRIMARY VACUUM BREAK

**NOTE** — This adjustment is performed using the choke valve angle gauge, see procedure at beginning of Adjustments.

1) Using an outside vacuum source of at least 15 in. Hg, seat primary choke vacuum break diaphragm. See Fig. 7.

## ROCHESTER MODELS 2SE &amp; E2SE 2-BARREL (Cont.)

**NOTE** — On delay models with air bleed, plug hole in cover with masking tape. Remove tape after adjustment. Also, make sure diaphragm plunger bucking spring (if equipped) is compressed.

2) Close choke valve by pushing on intermediate choke lever. Bubble on choke valve angle gauge should be centered with specified degree mark opposite pointer.

3) To adjust, bend primary vacuum break rod until bubble of choke valve angle gauge is centered.

2) Rotate cover in specified direction to align reference mark on cover with specified graduation in housing. Tighten cover screws.

## CHOKE UNLOADER

**NOTE** — This adjustment is performed using the choke valve angle gauge, see procedure at beginning of adjustments.

1) Adjust automatic choke as previously outlined. Hold throttle valves wide open.

2) If engine is warm, close choke valve by pushing in on choke intermediate lever. Hold in position with a rubber band.

3) Bubble on choke valve angle gauge should be centered with specified degree mark opposite pointer.

4) To adjust, bend choke unloader tang on throttle lever until bubble of choke valve angle gauge is centered.

## SECONDARY VACUUM BREAK

**NOTE** — This adjustment is made using the choke valve angle gauge, see procedure at beginning of Adjustments.

1) Using an outside vacuum source of at least 15 in. Hg., seat secondary choke vacuum break diaphragm. See Fig. 8.

2) Close choke valve by pushing on intermediate choke lever. Make sure bucking spring on diaphragm plunger (if equipped) is fully compressed and seated.

3) Bubble on choke valve angle gauge should be centered with specified degree mark opposite pointer.

4) To adjust, bend secondary break vacuum rod until bubble of choke valve angle gauge is centered.

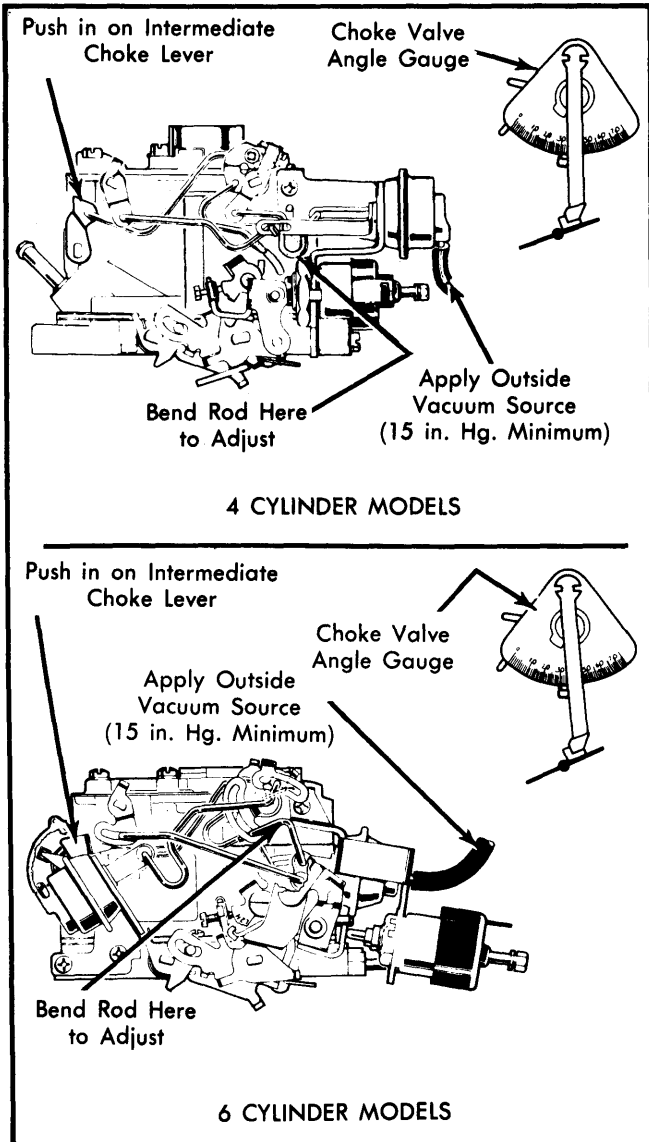

Fig. 7 Primary Vacuum Break Adjustment

## AUTOMATIC CHOKE

**NOTE** — Choke coil cover is retained on housing with rivets to prevent tampering with factory adjustment. If necessary to remove cover, refer to Disassembly and Reassembly procedures in this Section.

1) Loosen 3 choke cover retaining screws. Position fast idle speed screw on high step of fast idle cam.

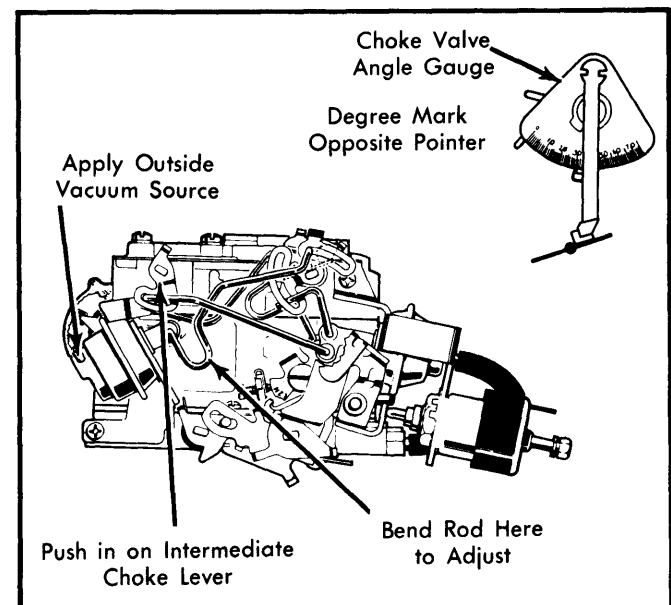

Fig. 8 Secondary Vacuum Break Adjustment

## ROCHESTER MODELS 2SE & E2SE 2-BARREL (Cont.)

### SECONDARY LOCK OUT

- 1) Hold choke valve wide open by pulling out on choke intermediate lever. See Fig. 9.
- 2) Open throttle valves until end of second actuating lever is opposite toe of lockout lever.
- 3) Measure clearance between end of actuating lever and toe of lockout lever. Measurement can be checked using a drill or pin gauge of specified size.
- 4) To adjust, bend lockout lever tang contacting fast idle cam.

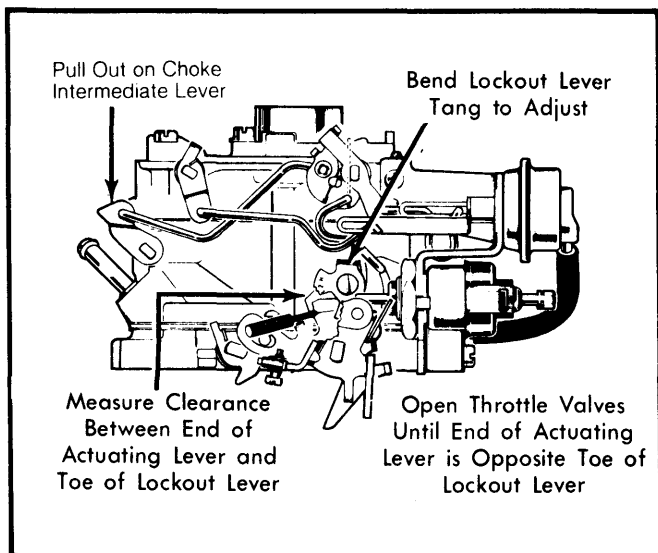

Fig. 9 Adjusting Secondary Throttle Lockout

## OVERHAUL

### DISASSEMBLY

**NOTE** — Before disassembling carburetor, mount unit in a suitable holding fixture to prevent damage to throttle valves or linkage.

**Air Horn** — 1) Bend back tabs on idle speed solenoid lock washer. Remove large solenoid retaining nut. Care must be taken when loosening nut to avoid damaging linkage, solenoid bracket, throttle lever or vacuum break. Remove solenoid and washer from bracket.

2) Remove accelerator pump lever retaining screw from air horn. Rotate pump lever to disengage from pump rod. Remove vacuum hose from primary (front) vacuum break diaphragm.

3) Remove primary (front) vacuum break diaphragm bracket screws. Rotate diaphragm and bracket assembly to disconnect rods from vacuum break lever and air valve lever.

**NOTE** — It is not necessary to disconnect vacuum break or air valve rods from vacuum break diaphragm plunger. If necessary to replace rods, remove retaining clips and remove rods. Save plastic bushing on ends of rods for reuse.

4) Remove idle speed solenoid/secondary (rear) vacuum break bracket screws. Rotate bracket to disconnect rod from secondary vacuum break lever.

**NOTE** — It is not necessary to disconnect secondary vacuum break rod from vacuum break diaphragm plunger. If necessary to replace rod, remove retaining clip and remove rod. Save plastic bushing on end of rod for reuse.

5) Remove and discard retaining clip from rod at choke intermediate lever. Remove choke rod and plastic bushing from lever.

6) Remove hot idle compensator valve screws. Remove valve and seal from air horn. Discard seal. Hot idle compensator must be removed to gain access to 1 air horn-to-float bowl screw.

7) On E2SE models, remove 3 mixture control solenoid screws and remove mixture control solenoid using a light twisting motion. Remove and discard solenoid gasket, plunger seal and plunger seal retainer.

8) Remove all air horn-to-float bowl screws and lock washers. Remove vent and screen assembly. Rotate fast idle cam up as far as possible. Rotate air horn and tilt to disengage fast idle cam rod from slot in fast idle cam.

9) Disconnect fast idle cam rod from choke lever by aligning tang on rod with slot in lever. Lift off air horn assembly.

10) Remove TPS plunger (E2SE models) by pushing through seal in air horn. Remove seal retainer and seal. Remove accelerator pump plunger seal from air horn.

11) It is not necessary to remove choke valve and shaft unless bent or damaged. Choke valve screws are staked in place. Staking must be removed before screws are removed.

**Float Bowl** — 1) Remove air horn gasket. Remove pump plunger and pump spring from pump well. Remove plastic filler block from float valve.

2) Remove float assembly and float valve by pulling up on retaining pin. Remove float needle seat and gasket using a suitable removal tool (J-22769).

3) On E2SE models, push up from bottom on electrical connector and remove TPS and connector from float bowl. Remove spring from bottom of TPS well in bowl. On 2SE models, press down on power piston stem and allow it to snap up. Repeat this until plastic retainer is dislodged and remove power piston and metering rod assembly.

4) Remove spring from power piston bore. If necessary to remove metering rod from hanger, compress spring on metering rod and align groove on rod with slot in holder. Care must be taken not to damage tip of metering rod.

5) Remove main metering jet using a screwdriver that fits tight in groove. Using a small slide hammer, remove plastic retainer holding pump discharge spring and check ball in place in float bowl. Discard retainer.

6) Align a .159" (No. 21) drill on choke cover retaining rivet and drill only enough to remove rivet head. Repeat for remain-

## ROCHESTER MODELS 2SE &amp; E2SE 2-BARREL (Cont.)

ing 2 rivets. Remove choke cover and coil assembly. Remove screw from end of intermediate choke lever in choke housing. Remove choke coil lever from shaft.

7) Slide intermediate choke shaft out of float bowl. Remove choke housing screws and remove choke housing. Remove fuel inlet nut, gasket, check valve/filter and spring.

8) Remove 4 screws securing throttle body to float bowl. Remove throttle body. Remove throttle body insulator gasket.

**Throttle Body** — 1) Hold throttle valves wide open. Disengage pump rod from throttle lever by rotating rod until tang on rod aligns with slot in lever.

2) Remove curb idle and fast idle speed screws and springs if necessary.

**NOTE** — It is not necessary to disassemble throttle body any further. Throttle valve screws are permanently staked in. Do not remove idle mixture screw plug unless it is necessary to replace mixture screw or cleaning and air pressure fails to clean idle mixture passage. If necessary to remove, proceed as follows:

3) Invert throttle body and position on a holding fixture with manifold side up. Position a punch in locator point in pilot hole on bottom of throttle body.

4) Holding punch vertical, drive punch through locator until hardened steel plug shatters. Hold punch at a 45° angle and break out throttle body casting to gain access to idle mixture screw plug. Drive out hardened steel plug.

**NOTE** — Hardened steel plug will shatter. It is not necessary to remove plug completely. Remove just enough pieces to allow idle mixture adjusting tool (J-28706) or a thin walled 3/16" deep socket to be used to remove mixture screw and spring.

## CLEANING &amp; INSPECTION

- Use a regular carburetor cleaning solution. Soak components long enough to thoroughly clean all surfaces and passages of foreign matter.
- Do not soak any components containing rubber, leather or plastic.
- Remove any residue after cleaning by rinsing components in a suitable solvent.
- Blow out all passages with dry compressed air.

## REASSEMBLY

**NOTE** — Use new gaskets and seals. Make sure new gaskets fit correctly and all holes are punched through and properly located.

To reassemble carburetor, reverse disassembly procedure and note the following:

1) Install fuel inlet needle pull clip over edge of flat on float arm facing float. Do not hook clip in holes in float arm.

2) After throttle body is installed on float bowl, make sure secondary lockout tang is in correct position to engage secondary lockout lever.

3) Install new accelerator pump discharge check ball and spring plastic retainer. Insert end of retainer in spring and place in position in float bowl. Lightly tap retainer into position until it is flush in float bowl.

4) Make sure holes in fuel filter face toward fuel inlet fitting when filter is installed.

5) Some linkage retaining clips are dished. Make sure portion of clip that bends outward is toward end of rod. Make sure clip makes full contact with rod.

**NOTE** — If choke coil cover was removed, it will be necessary to install self-tapping screws (supplied in service kit) to replace retainer rivets. Before installing cover, start self-tapping screws into choke housing, making sure they start easily and are properly aligned. Remove screws and proceed as follows:

6) Place fast idle screw on high step of fast idle cam. Install choke coil cover, aligning notch in cover with raised boss on housing cover flange. Install self-tapping screws and tighten.

7) Install air horn screws, noting location and type of screw for correct installation. Tighten all screws evenly, securely and in order shown in Fig. 10.

8) On E2SE models, install mixture control solenoid seal on solenoid stem. Using a 3/16" socket and hammer, lightly tap retainer in place, on stem, leaving a slight clearance between retainer and seal. Apply silicone grease to seal before installation of solenoid.

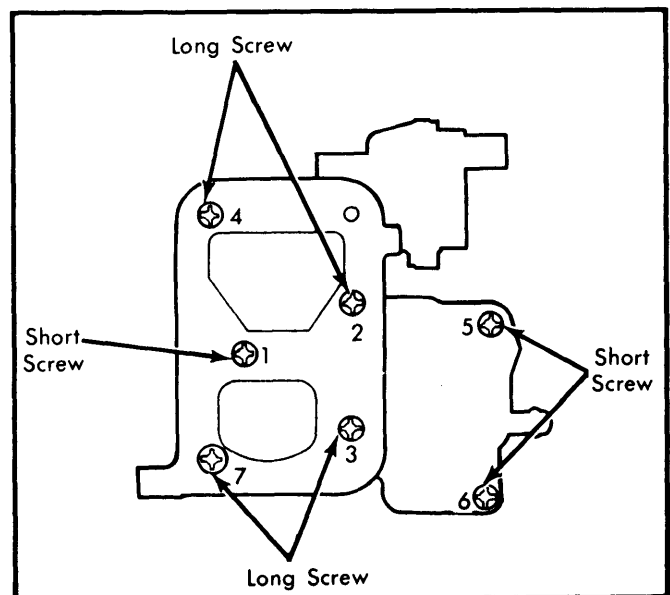
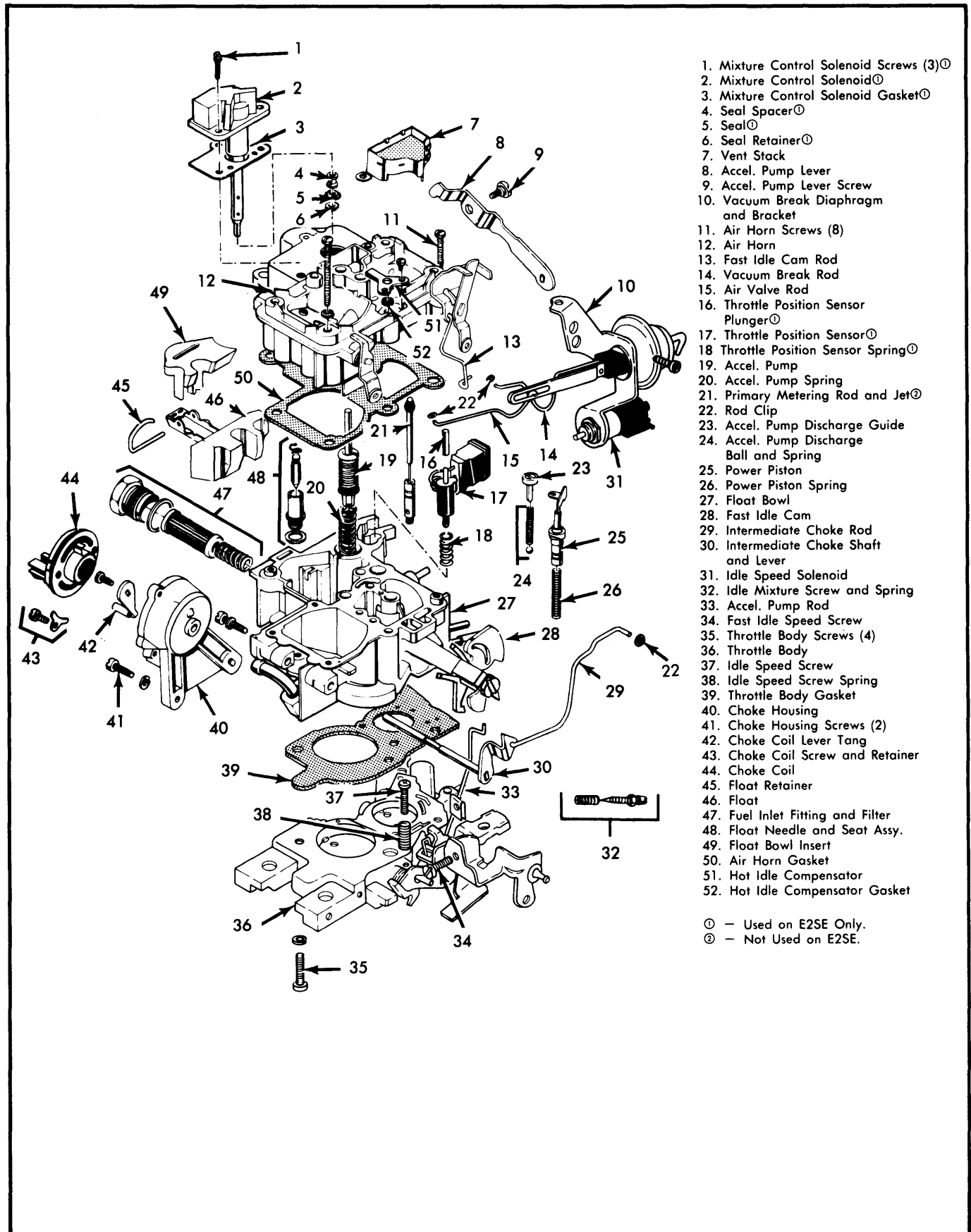

Fig. 10 Air Horn Screw Location and Tightening Sequence

## ROCHESTER MODELS 2SE & E2SE 2-BARREL (Cont.)



1. Mixture Control Solenoid Screws (3)①
2. Mixture Control Solenoid①
3. Mixture Control Solenoid Gasket①
4. Seal Spacer①
5. Seal①
6. Seal Retainer①
7. Vent Stack
8. Accel. Pump Lever
9. Accel. Pump Lever Screw
10. Vacuum Break Diaphragm and Bracket
11. Air Horn Screws (8)
12. Air Horn
13. Fast Idle Cam Rod
14. Vacuum Break Rod
15. Air Valve Rod
16. Throttle Position Sensor Plunger①
17. Throttle Position Sensor①
18. Throttle Position Sensor Spring①
19. Accel. Pump
20. Accel. Pump Spring
21. Primary Metering Rod and Jet②
22. Rod Clip
23. Accel. Pump Discharge Guide
24. Accel. Pump Discharge Ball and Spring
25. Power Piston
26. Power Piston Spring
27. Float Bowl
28. Fast Idle Cam
29. Intermediate Choke Rod
30. Intermediate Choke Shaft and Lever
31. Idle Speed Solenoid
32. Idle Mixture Screw and Spring
33. Accel. Pump Rod
34. Fast Idle Speed Screw
35. Throttle Body Screws (4)
36. Throttle Body
37. Idle Speed Screw
38. Idle Speed Screw Spring
39. Throttle Body Gasket
40. Choke Housing
41. Choke Housing Screws (2)
42. Choke Coil Lever Tang
43. Choke Coil Screw and Retainer
44. Choke Coil
45. Float Retainer
46. Float
47. Fuel Inlet Fitting and Filter
48. Float Needle and Seat Assy.
49. Float Bowl Insert
50. Air Horn Gasket
51. Hot Idle Compensator
52. Hot Idle Compensator Gasket

① - Used on E2SE Only.  
 ② - Not Used on E2SE.

**Fig. 11 Exploded View of Rochester Model 2SE and E2SE 2-Barrel Carburetor (4 CYLINDER MODELS)**

# 1980 Rochester Carburetors

## ROCHESTER MODELS 2SE & E2SE 2-BARREL (Cont.)

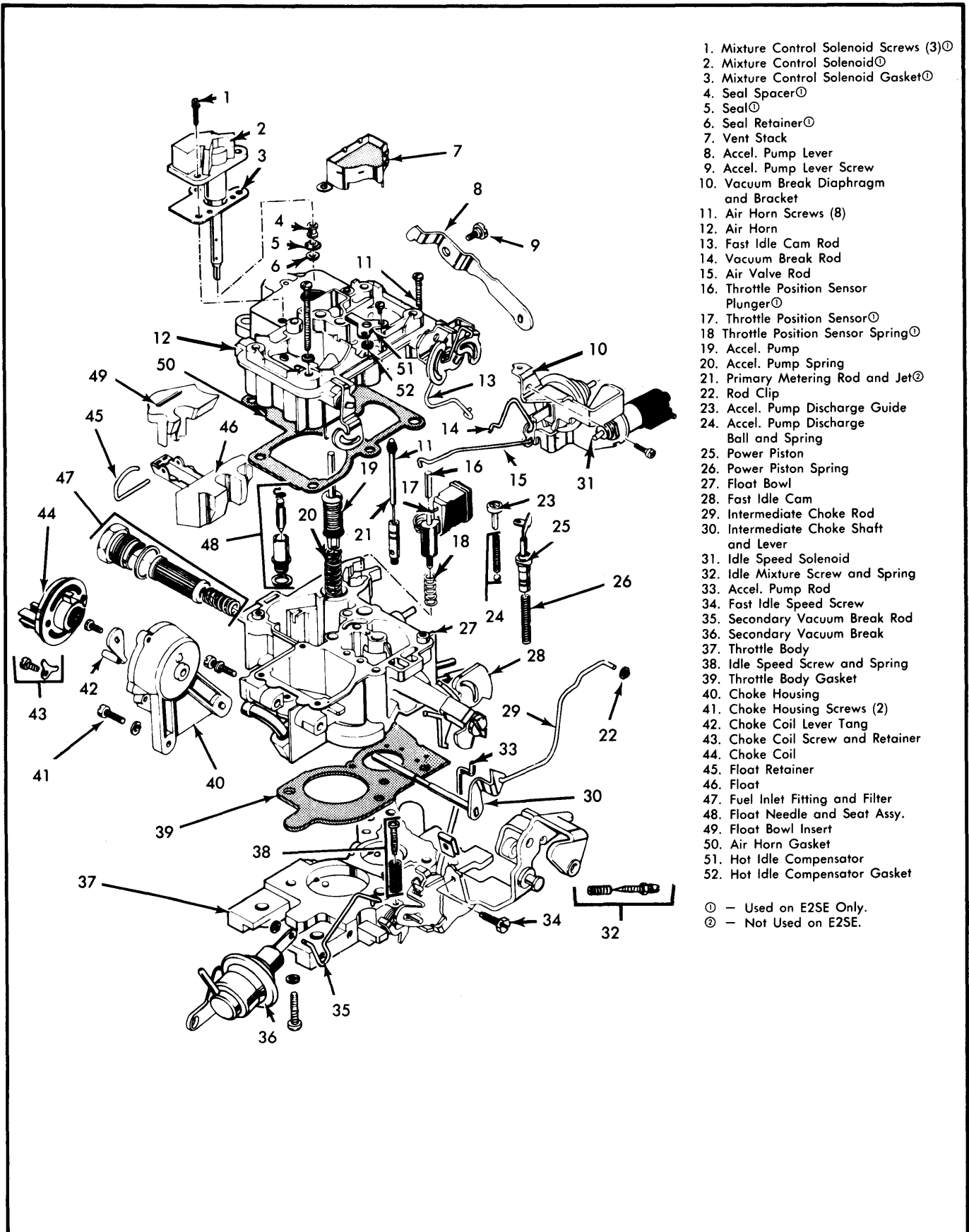

1. Mixture Control Solenoid Screws (3)⓪
2. Mixture Control Solenoid⓪
3. Mixture Control Solenoid Gasket⓪
4. Seal Spacer⓪
5. Seal⓪
6. Seal Retainer⓪
7. Vent Stack
8. Accel. Pump Lever
9. Accel. Pump Lever Screw
10. Vacuum Break Diaphragm and Bracket
11. Air Horn Screws (8)
12. Air Horn
13. Fast Idle Cam Rod
14. Vacuum Break Rod
15. Air Valve Rod
16. Throttle Position Sensor Plunger⓪
17. Throttle Position Sensor⓪
18. Throttle Position Sensor Spring⓪
19. Accel. Pump
20. Accel. Pump Spring
21. Primary Metering Rod and Jet⓪
22. Rod Clip
23. Accel. Pump Discharge Guide
24. Accel. Pump Discharge Ball and Spring
25. Power Piston
26. Power Piston Spring
27. Float Bowl
28. Fast Idle Cam
29. Intermediate Choke Rod
30. Intermediate Choke Shaft and Lever
31. Idle Speed Solenoid
32. Idle Mixture Screw and Spring
33. Accel. Pump Rod
34. Fast Idle Speed Screw
35. Secondary Vacuum Break Rod
36. Secondary Vacuum Break
37. Throttle Body
38. Idle Speed Screw and Spring
39. Throttle Body Gasket
40. Choke Housing
41. Choke Housing Screws (2)
42. Choke Coil Lever Tang
43. Choke Coil Screw and Retainer
44. Choke Coil
45. Float Retainer
46. Float
47. Fuel Inlet Fitting and Filter
48. Float Needle and Seat Assy.
49. Float Bowl Insert
50. Air Horn Gasket
51. Hot Idle Compensator
52. Hot Idle Compensator Gasket

⓪ — Used on E2SE Only.  
 Ⓛ — Not Used on E2SE.

**Fig. 12 Exploded View of Rochester Model 2SE and E2SE 2-Barrel Carburetor (6 CYLINDER MODELS)**

# 1980 Rochester Carburetors

## ROCHESTER MODELS 2SE & E2SE 2-BARREL (Cont.)

CARBURETOR ADJUSTMENT SPECIFICATIONS										
Application	Float Level Setting	Accel. Pump Setting	Choke Coil Lever Setting	Choke Rod Setting	Air Valve Rod Setting	Vacuum Break		Auto. Choke Setting	Choke Unloader Setting	Secondary Lockout Setting
						Primary Setting	Secondary Setting			
<b>American Motors</b>										
17080681	3/16"	17/32"	.085"	18°	2°	20°	.....	Index	32°	.....
17080683	3/16"	1/2"	.085"	18°	2°	20°	.....	Index	32°	.....
17080686	3/16"	1/2"	.085"	18°	2°	20°	.....	Index	32°	.....
17080688	3/16"	1/2"	.085"	18°	2°	20°	.....	Index	32°	.....
17080781	7/32"	1/2"	.085"	18°	2°	20°	.....	Index	32°	.....
17080782	7/32"	1/2"	.085"	18°	2°	20°	.....	Index	32°	.....
<b>General Motors</b>										
17059614	7/32"	1/2"	.085"	18°	2°	17°	.....	Index	36°	.....
17059615	7/32"	17/32"	.085"	18°	2°	19°	.....	Index	36°	.....
17059616	7/32"	1/2"	.085"	18°	2°	17°	.....	Index	36°	.....
17059617	7/32"	17/32"	.085"	18°	2°	19°	.....	Index	36°	.....
17059618	7/32"	1/2"	.085"	18°	2°	17°	.....	Index	36°	.120"
17059619	7/32"	17/32"	.085"	18°	2°	19°	.....	Index	36°	.....
17059620	7/32"	1/2"	.085"	18°	2°	17°	.....	Index	36°	.....
17059621	7/32"	17/32"	.085"	18°	2°	19°	.....	Index	36°	.....
17059622	3/16"	17/32"	.085"	18°	2°	17°	.....	Index	36°	.....
17059623	.....	.....	.085"	.....	2°	.....	.....	Index	.....	.....
17059624	3/16"	17/32"	.085"	18°	2°	17°	.....	Index	36°	.....
17059625	.....	.....	.085"	.....	2°	.....	.....	Index	.....	.....
17059650	1/4"	17/32"	.085"	27°	2°	30°	38°	Index	30°	.....
17059651	1/4"	17/32"	.085"	27°	2°	30°	37°	Index	30°	.....
17059652	1/4"	17/32"	.085"	27°	2°	30°	38°	Index	30°	.....
17059653	1/4"	17/32"	.085"	27°	2°	30°	37°	Index	30°	.....
17059660	1/4"	17/32"	.085"	27°	2°	30°	32°	Index	30°	.....
17059662	1/4"	17/32"	.085"	27°	2°	30°	32°	Index	30°	.....
17059664	1/4"	17/32"	.085"	27°	2°	30°	32°	Index	30°	.....
17059665	1/4"	17/32"	.085"	27°	2°	30°	32°	Index	30°	.....
17059714	3/16"	1/2"	.085"	18°	2°	19°	.....	Index	32°	.....
17059715	3/16"	1/2"	.085"	18°	2°	21°	.....	Index	32°	.....
17059716	3/16"	1/2"	.085"	18°	2°	19°	.....	Index	32°	.....
17059717	3/16"	1/2"	.085"	18°	2°	21°	.....	Index	32°	.....
17059718	3/16"	1/2"	.085"	18°	2°	19°	.....	Index	32°	.....
17059720	3/16"	1/2"	.085"	18°	2°	19°	.....	Index	32°	.....
17059721	3/16"	17/32"	.085"	18°	2°	23°	.....	Index	32°	.....
17059722	3/16"	15/32"	.085"	18°	2°	19°	.....	Index	32°	.....
17059723	3/16"	17/32"	.085"	18°	2°	23°	.....	Index	32°	.....
17059724	3/16"	15/32"	.085"	18°	2°	19°	.....	Index	32°	.....
17059760	1/4"	1/2"	.085"	16°	2°	24°	30°	Index	35°	.....
17059762	1/4"	.....	.085"	16°	2°	24°	30°	Index	35°	.120"
17059763	1/4"	.....	.085"	16°	2°	24°	33°	Index	35°	.120"
17059768	1/4"	.....	.085"	16°	2°	24°	30°	Index	35°	.....