

## HOLLEY MODEL 6500 & 6510-C 2-BARREL

### CARBURETOR APPLICATION

**NOTE:** Some Chrysler Corp. Omni and Horizon models use the Holley 6520 2-barrel carburetor. See 1981 supplement FUEL SYSTEMS section for information on this carburetor.

#### FORD MOTOR CO. (MODEL 6500)

Application	Ford Motor Co. Part No.	
	Man. Trans.	Auto. Trans.
140" (2.3 Liter) 4 Cylinder California		
Without A/C .....	EOEE-VA .....	EOZE-AFA
With A/C .....	EOEE-NA .....	EOZE-SA
Turbocharged .....	EOZE-AZA .....	EOZE-ATA

#### GENERAL MOTORS - CHEVROLET (MODEL 6510-C)

Application	Chevrolet Part No.	
	Man. Trans.	Auto. Trans.
98" (1.6 Liter) 4 Cylinder California		
Without A/C .....	14004472 .....	14004470
With A/C .....	14004471 .....	14004469

### CARBURETOR IDENTIFICATION

Carburetor part number or identification number may be found stamped on the fuel bowl assembly or on a metal tag attached to carburetor.

### DESCRIPTION

The Holley model 6500 and 6510-C carburetor is referred to as a "Feedback" type carburetor. It is similar in design to the Holley 5200 series carburetor. The 6500 series carburetors are equipped with an externally variable auxiliary "Feedback" fuel metering system, rather than an enrichment (power) valve used on the 5200 series carburetors.

The "Feedback" type metering system, used on the 6500 model, is controlled through vacuum. The vacuum is regulated through an electronic control unit. The control unit increases or decreases vacuum depending upon readings taken from an oxygen sensor mounted in the exhaust manifold.

The 6510-C is used in conjunction with the Computer Controlled Catalytic Converter System (C-4). The carburetor is equipped with an electrically actuated mixture control solenoid mounted on the air horn and extending into the float bowl and power enrichment valve bore (power enrichment valve is not used on these models).

The mixture control solenoid is activated by an electric signal from the Electronic Control Module (ECM). The ECM receives a signal from the oxygen sensor mounted in the exhaust manifold. The ECM will signal the solenoid to either lower its plunger to lean the mixture or raise its plunger to richen the mixture.

A Throttle Position Sensor (TPS) is used to signal the ECM of throttle position changes as they occur. When throttle position is changed, a tang on the throttle linkage moves the TPS plunger. This signals the ECM to hold the last known air/fuel

ratio to aid in throttle response. Under wide open throttle conditions, the TPS signals the ECM to hold the mixture control solenoid in full rich position.

### ADJUSTMENTS

#### HOT (SLOW) IDLE RPM

See appropriate article in TUNE-UP SERVICE PROCEDURES.

#### IDLE MIXTURE

See appropriate article in TUNE-UP SERVICE PROCEDURES.

#### COLD (FAST) IDLE RPM

See appropriate article in TUNE-UP SERVICE PROCEDURES.

#### MIXTURE CONTROL SOLENOID

See appropriate article in TUNE-UP SERVICE PROCEDURES.

#### FLOAT LEVEL

1) With air horn removed, turn upside down. Allow weight of float to press down against float needle valve. See Fig. 1.

2) Measure float level specified clearance between top of float and air horn gasket surface. Clearance can be checked using a specified drill or pin gauge.

3) Make sure float tang still rests on float needle when clearance is checked. To adjust bend tang that contacts float needle.

**NOTE** - Do not apply pressure to float needle while checking or changing adjustment.

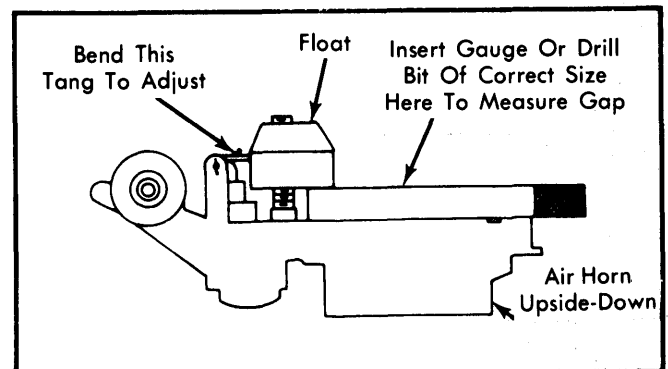

Fig. 1 Adjusting Float Level

#### CHOKE VACUUM BREAK (INITIAL CHOKE VALVE CLEARANCE)

**NOTE** - General Motors models use tamper-proof screws to retain choke coil cover. File screw heads until cover retaining ring can be removed and then remove remaining portion of cover screws from choke housing. (New screws are supplied in service kit.)

1) Remove retaining screws from choke coil cover. Remove choke coil cover and choke coil. See Fig. 2.

# 1980 Holley Carburetors

## HOLLEY MODEL 6500 & 6510-C 2-BARREL (Cont.)

2) On Ford models, position fast idle speed screw on second step of fast idle cam. Rotate choke coil lever inside choke housing to close choke.

3) Using a screwdriver, push vacuum diaphragm stem in until it reaches stop (Ford models) or apply an outside vacuum source to seat vacuum break diaphragm. Apply light closing pressure to choke valve.

4) Measure choke vacuum break specified clearance between lower edge of choke valve and air horn wall. Clearance can be measured using a specified drill or pin gauge.

5) To adjust, turn adjusting screw in end of choke vacuum diaphragm using a  $\frac{5}{32}$ " Allen wrench. Install choke coil cover and adjust to specifications

2) Measure fast idle cam specified clearance between lower edge of choke valve and air horn wall. Clearance can be measured using a specified drill or pin gauge.

3) With clearance correct, choke lever tang should just contact lever on fast idle cam. To adjust, bend choke lever tang.

### CHOKE UNLOADER

**General Motors Only** - 1) Hold throttle valves wide open. Measure choke unloader specified clearance between lower edge of choke valve and air horn wall. See Fig. 4.

2) Clearance can be measured using a specified drill or pin gauge. To adjust, bend choke unloader tang on fast idle cam.

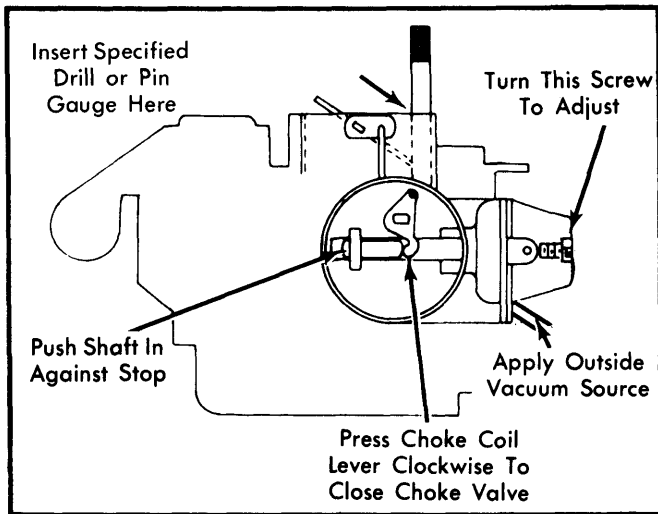

**Fig. 2 Adjusting Choke Vacuum Break (Initial Choke Valve Clearance)**

### FAST IDLE CAM POSITION

1) Place fast idle speed screw on low step of fast idle cam (Ford models) or second highest step of fast idle cam (General Motors models), against shoulder of next highest step. See Fig. 3.

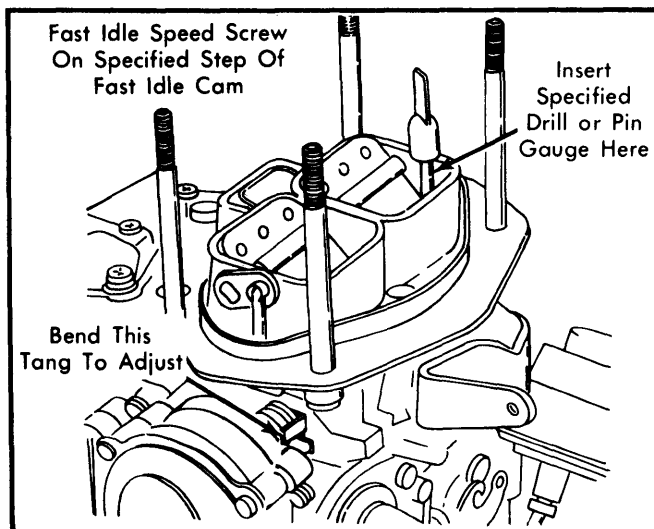

**Fig. 3 Adjusting Fast Idle Cam Position**

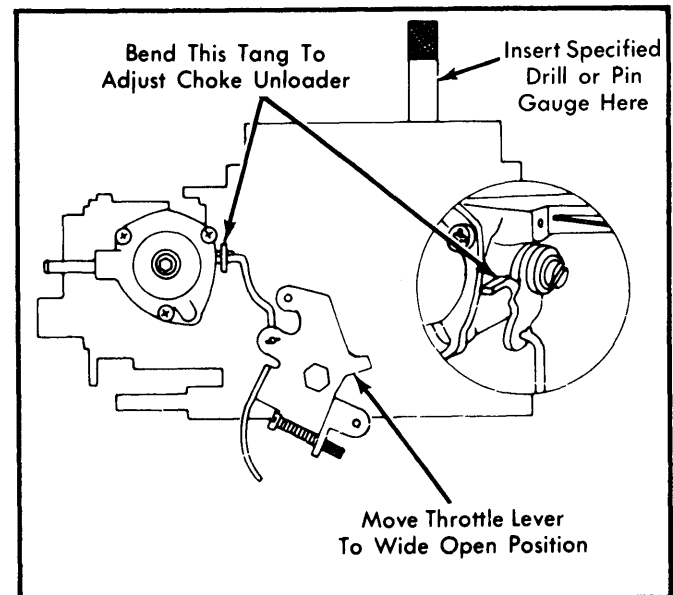

**Fig. 4 Adjusting Choke Unloader**

### AUTOMATIC CHOKE

**NOTE** - General Motors models use tamper-proof screws to retain choke coil cover. File screw heads until cover retaining ring can be removed and then remove remaining portion of cover screws from choke housing. (New screws are supplied in service kit.)

1) Loosen choke coil cover retaining screws. Rotate choke coil cover until index mark on cover is aligned with correct setting on choke housing.

2) Housing is not marked for a rich or lean setting. Rotate cover clockwise for rich setting and counterclockwise for a lean setting.

### SECONDARY THROTTLE STOP SCREW

1) Back off secondary throttle stop screw until secondary valve seats in bore. See Fig. 5

2) Turn screw in until it just contacts tab on secondary throttle lever. Now turn screw an additional  $\frac{1}{4}$  turn.

## HOLLEY MODEL 6500 & 6510-C 2-BARREL (Cont.)

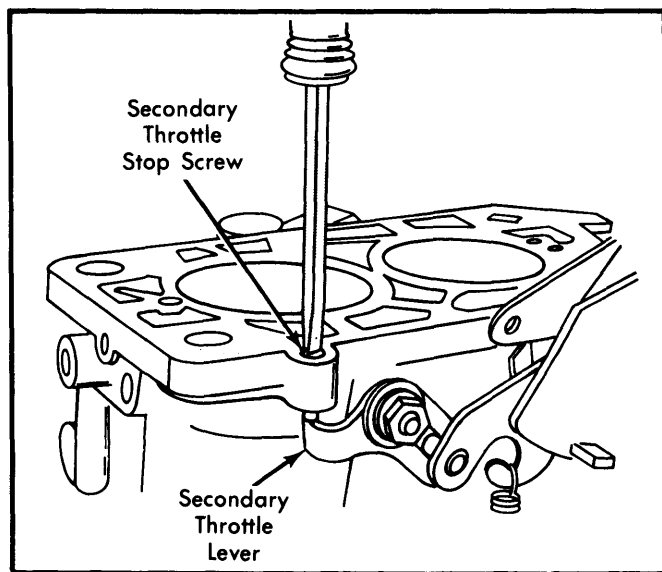

Fig. 5 Adjusting Secondary Throttle Stop Screw

### OVERHAUL

#### DISASSEMBLY

**Air Horn** – 1) Remove mixture control solenoid screws and solenoid (General Motors models only). Pry choke rod loose from choke lever. Remove air horn screws and lockwashers. Carefully separate air horn from main body.

2) Disconnect choke rod from choke lever. Remove choke rod and dust seal. Remove float hinge pin. Remove float and fuel inlet needle. Remove fuel inlet needle seat and gasket.

3) Remove 3 "Feedback" fuel metering diaphragm cover screws. Remove cover, spring and diaphragm and needle valve assembly (Ford models only).

4) Remove 3 bowl vent valve cover screws and remove cover. Remove clip from bowl vent valve diaphragm stem. Remove retainer, spring (if equipped) and diaphragm.

5) On Ford models, pry vent valve paddle pivot pin toward fuel inlet seat. Remove pin and vent valve paddle. Remove power enrichment valve screws and remove power enrichment diaphragm.

6) Remove idle solenoid (if equipped). Remove fuel inlet fitting, gasket and filter.

**Main Body** – 1) Remove 3 choke cover retaining screws. Remove retaining ring and choke coil cover. Remove choke vacuum diaphragm cover screws. Remove cover and spring.

**NOTE** – General Motors models use tamper-proof screws to retain choke coil cover. File screw heads until cover retaining ring can be removed and then remove remaining portion of cover screws from choke housing. (New screws are supplied in service kit.)

2) Rotate cam on choke shaft to allow diaphragm shaft to be removed. Remove choke housing screws, pull housing away and disconnect fast idle cam rod. Remove housing.

3) On Ford models, remove "O" ring from vacuum passage in choke housing. On all models, remove choke shaft nut in choke housing. Remove choke lever and fast idle cam. Remove fast idle speed screw and spring.

4) Remove 4 accelerator pump cover screws. Remove accelerator pump diaphragm and spring. Remove accelerator pump discharge nozzle. Turn main body over and catch both check balls.

**NOTE** – General Motors models have TPS mounted in accelerator pump cover. Use care in removing connector and solenoid. DO NOT soak accelerator pump cover in carburetor cleaner unless TPS has been removed first.

5) Remove primary and secondary high speed bleed plugs. Note size and position for reassembly. Turn main body upside down and catch primary and secondary main well tubes. Note size and position for reassembly.

6) Remove primary and secondary main jets. Note size and position for reassembly. Remove power valve and gasket.

7) On Ford models, remove secondary idle jet retainer and remove idle jet located on side of carburetor.

8) Remove idle limiter cap. Count number of turns required to gently seat mixture screw for reference during reassembly. Remove idle mixture screw and plug.

9) Remove secondary operating lever and return spring. Remove nut and lock washer from end of primary throttle shaft. Remove accelerator pump cam. Remove idle speed screw and spring from throttle lever.

10) On General Motors models, remove 2 screws from hot idle compensator cover. Remove hot idle compensator and gasket.

#### CLEANING & INSPECTION

- Do not immerse plastic or rubber parts in solvent. Do not immerse diaphragm assemblies or solenoid in solvent.
- Blow out all passages with compressed air. Do not use wire or drill bit to clean carburetor orifices.
- Inspect all parts for wear, cracks, nicks or burrs, and damage. Replace parts as necessary.
- After cleaning with solvent, wash all parts in hot water and blow dry with compressed air.

#### REASSEMBLY

To reassemble carburetor, reverse disassembly procedures. Use new gaskets and seals. Make sure that new gaskets fit correctly and that all holes and slots are punched through and correctly located.

**NOTE** – When installing "Feedback" diaphragm (Ford models only), tighten 3 cover screws to 4-5 INCH lbs.

# 1980 Holley Carburetors

## HOLLEY MODEL 6500 & 6510-C 2-BARREL (Cont.)

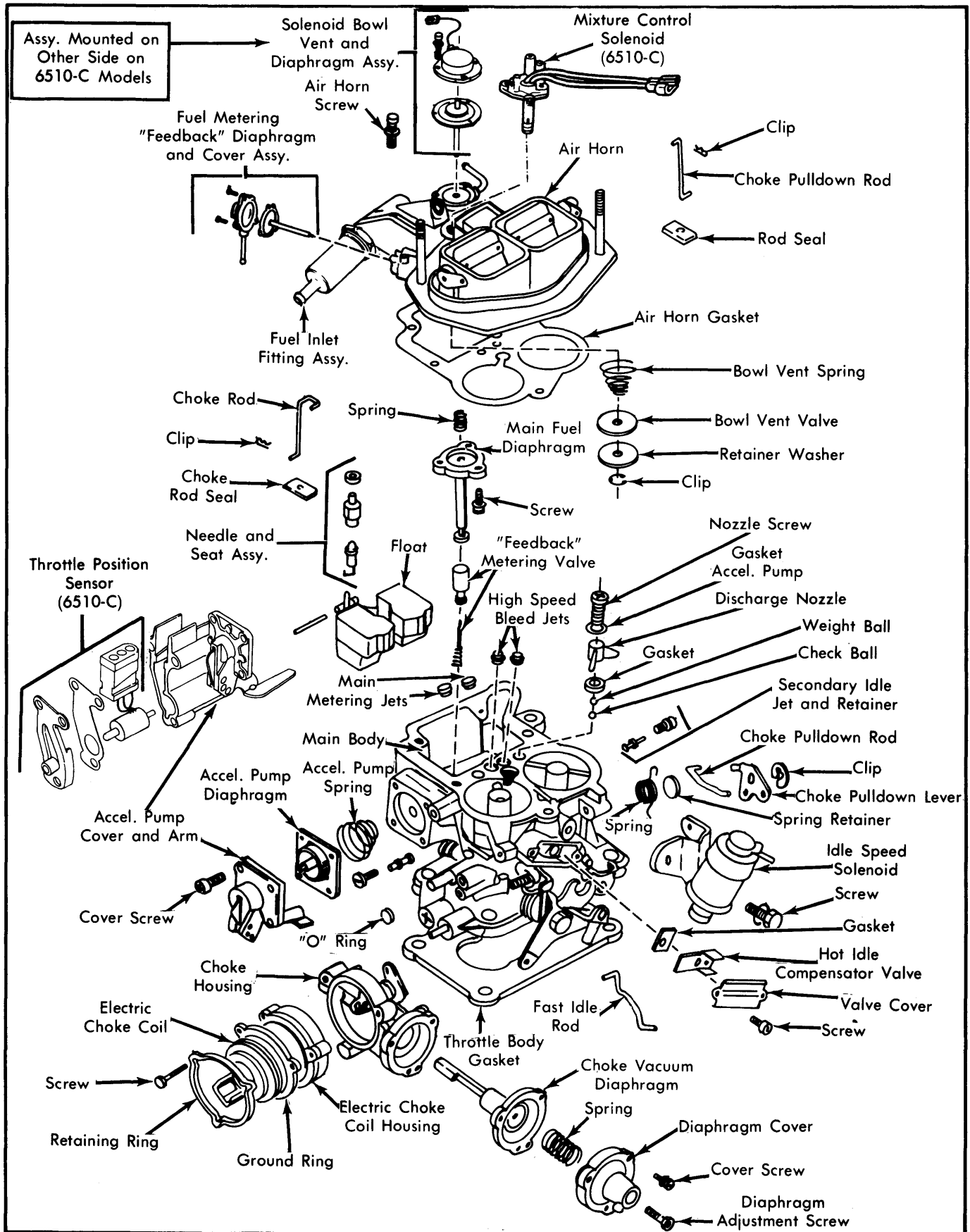

Fig. 6 Exploded View of Holley Model 6500 and 6510-C 2-Barrel Carburetor

# 1980 Holley Carburetors

## HOLLEY MODEL 6500 & 6510-C 2-BARREL (Cont.)

CARBURETOR ADJUSTMENT SPECIFICATIONS					
Application	Float Level Setting	Choke Vacuum Break Setting	Fast Idle Cam Setting	Choke Unloader Setting	Auto Choke Setting
<b>Ford Motor Co. (6500 Model)</b>					
EOEE-NA	15/32"	.236"	.118"	.394"	Index
EOEE-VA	15/32"	.236"	.118"	.394"	Index
EOZE-AFA	15/32"	.236"	.118"	.394"	Index
EOZE-ATA	15/32"	.236"	.118"	.394"	Index
EOZE-AZA	15/32"	.236"	.118"	.394"	Index
EOZE-SA	15/32"	.236"	.118"	.394"	Index
<b>General Motors (6510-C Model)</b>					
14004469	33/64"	.300"	.130"	.350"	⊙
14004470	33/64"	.275"	.130"	.350"	⊙
14004471	33/64"	.300"	.130"	.350"	⊙
14004472	33/64"	.275"	.130"	.350"	⊙

⊙ - No adjustment required.