

4-30 1975-79 DISTRIBUTORS & IGNITION SYSTEMS

Prestolite BID Ignition System

1975-77 Jeep

DESCRIPTION & OPERATION

The Breakerless Inductive Discharge (BID) ignition system uses an Electronic Control Unit (ECU) to control system, a breakerless distributor and an oil filled coil. When ignition switch is on, primary circuit is on and ignition coil is energized. As distributor shaft rotates, the distributor generates signals causing module to break primary current and induce secondary voltage in coil. A timing circuit in module turns primary circuit on again to energize coil for next spark cycle. The dwell is controlled by electronic module and angle between trigger teeth, and is not adjustable.

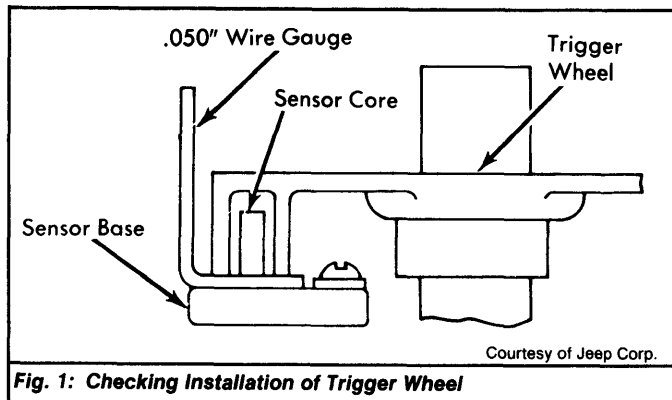

Fig. 1: Checking Installation of Trigger Wheel

ADJUSTMENTS

Trigger Wheel - Press trigger wheel onto distributor shaft until teeth of trigger wheel are .050-.060" from sensor base. See Fig. 1.

Sensor Position - 1) Install sensor positioning gauge over yoke making sure gauge is against flat of shaft. Move sensor to side until gauge can be positioned. Snug down retaining screw. Remove and then install gauge. If sensor is properly positioned, no sensor side movement should be detected when gauge is removed or installed.

2) Tighten screw and recheck sensor position. When trigger wheel is installed, sensor core should be positioned in center of trigger wheel legs and legs should not touch sensor core. See Fig. 2.

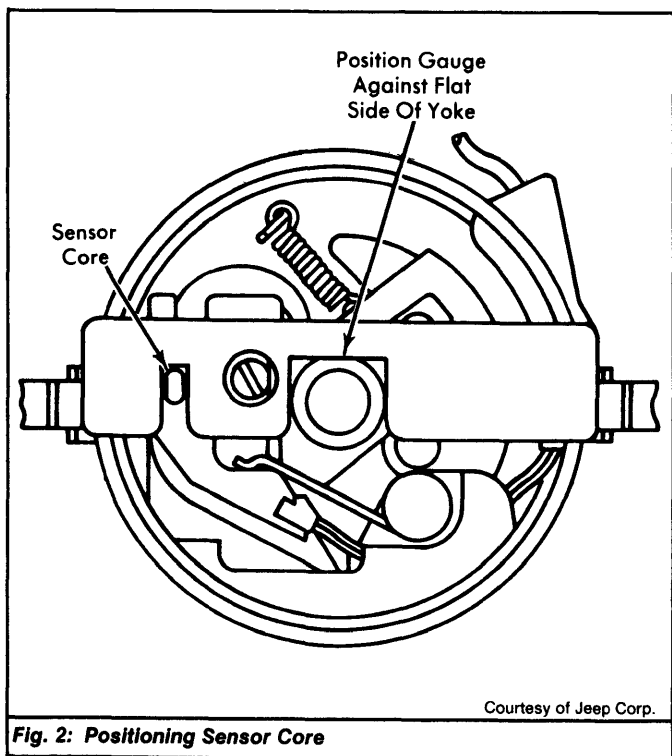

Fig. 2: Positioning Sensor Core

TESTING

NOTE: Before starting tests, make sure battery is fully charged and delivers 12-13 volts. Check all wiring and connectors for damage or loose connections. Replace any high tension cable which show signs of cracks or deterioration.

1) Disconnect Electronic Control Unit (ECU) ground and 4-wire connector. Clean all connectors and terminals to ECU. Disconnect battery cables from battery. Momentarily place ignition switch to "START" position, then in "ON" position. Check resistance of feed circuit by connecting ohmmeter to positive battery cable (B1) and terminal F3 of 4-wire connector. See Fig. 3.

2) If resistance is less than one ohm, tighten attaching screw for main harness connector. If resistance is one ohm or greater, check resistance at points B1-B2, B2-A1, A1-H1, F3-C1, C1-H2, and AV-DV. Clean, tighten, reposition, repair or replace connectors as needed.

3) Check all primary wiring connections for proper assembly and tightness. Wire terminals must be between channel washer and nut. Washer tabs must face up. Check primary circuit resistance by connecting ohmmeter to terminals F3 and F4. If resistance is less than one ohm, replace coil and go to step 5). If resistance is greater than 2 ohms, check resistance at the following terminals: C1-C2 (1-2 ohms), F3-C1 (0 ohms), and F4-C2 (0 ohms). Replace coil or repair wiring as necessary. If resistance is 1-2 ohms, go to next step.

4) Remove coil-to-distributor wire at coil tower and connect ohmmeter between C1 and coil tower. If resistance is 9000-15,000 ohms, reinstall coil wire and continue testing. If resistance is not within specifications, replace coil before continuing testing.

5) Remove distributor cap, rotor and dust cover. Connect ohmmeter to terminals F1 and F2 to check resistance of sensor circuit. Observe ohmmeter while applying side pressure to sensor post, wiggling sensor wire grommet at distributor, and flexing and lightly pulling sensor wires and 2-wire connector. Ohmmeter reading should be 1.6-2.4 ohms and should not waver or fluctuate.

6) If reading is not within specifications, disconnect 2-wire connector and connect ohmmeter to terminals S1 and S2. If resistance is still not within specifications, wavers or fluctuates, replace sensor assembly. If resistance is now within specifications and steady, proceed with testing.

7) Clean terminals S1, S2, S3, and S4. Connect ohmmeter to terminal G2 and battery ground cable. Resistance should be zero ohms. Clean and retighten ground connections as necessary. Apply a film of petroleum jelly to male terminals on 4-wire and ground connectors and also to outer edge of terminal end of ECU 4-wire connector. Connect the ground and 4-wire connector.

8) Connect Pulse Simulator (J-25331) to terminals S3 and S4. Connect battery cables to battery. Remove coil-to-distributor wire at coil tower and hold wire end 1/2" from a known good ground. With ignition switch in "ON" position, operate simulator. If spark jumps 1/2" gap, proceed to step 10).

9) If spark will not jump gap, disconnect coil negative terminal. Connect one lead from pulse simulator to terminal and other lead to a good ground. Hold coil wire 1/2" from ground and operate simulator. If spark now jumps gap, replace ECU. If spark still will not jump gap, replace coil.

10) Disconnect pulse simulator. Apply a film of petroleum jelly to male terminals before connecting 2-wire connector. Connect coil negative terminal wire. Inspect distributor cap, dust cover, and coil-to-distributor wire, then reinstall components.

IGNITION SYSTEM SPECIFICATIONS

Application	Specification
Sensor Resistance (@77°F)	1.6-2.4 Ohms
Ignition Coil	
Primary Resistance	1-2 Ohms
Secondary Resistance	9000-15,000 Ohms
Open Circuit Voltage (Minimum)	20,000 Volts

4-32 1975-79 DISTRIBUTORS & IGNITION SYSTEMS Prestolite BID Ignition System (Cont.)

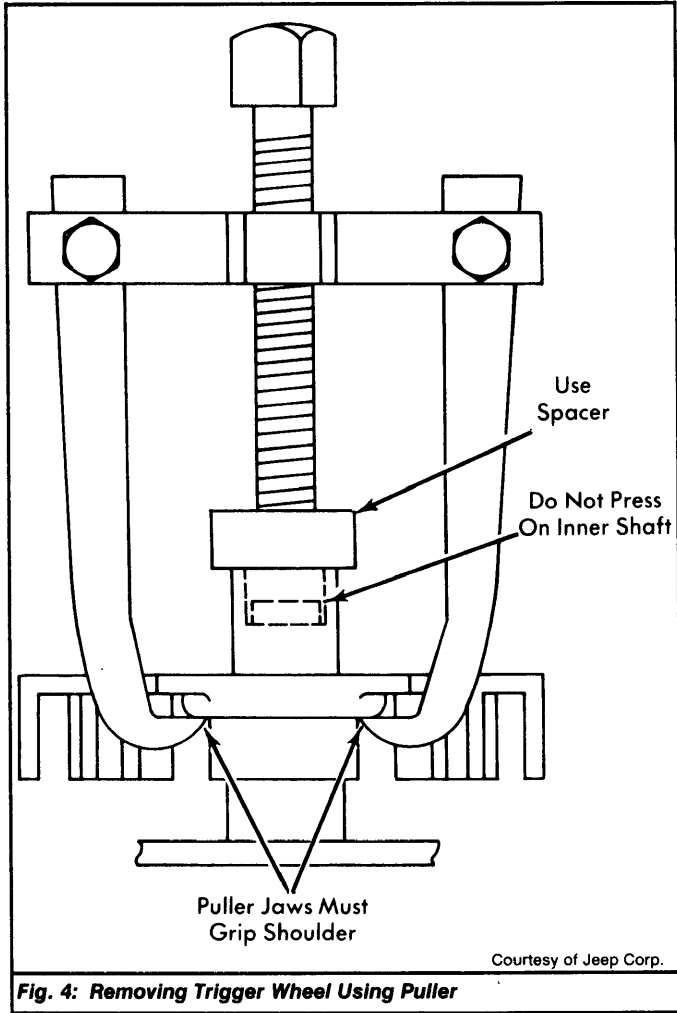

Fig. 4: Removing Trigger Wheel Using Puller

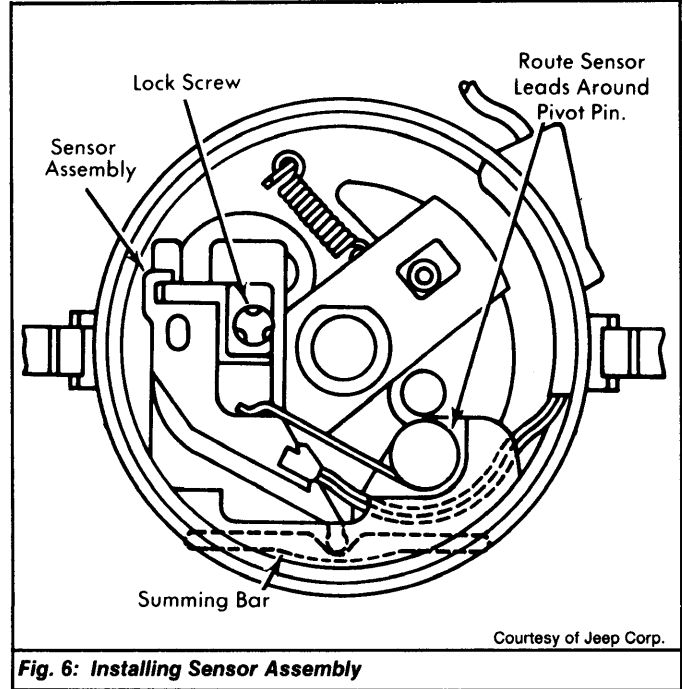

Fig. 6: Installing Sensor Assembly

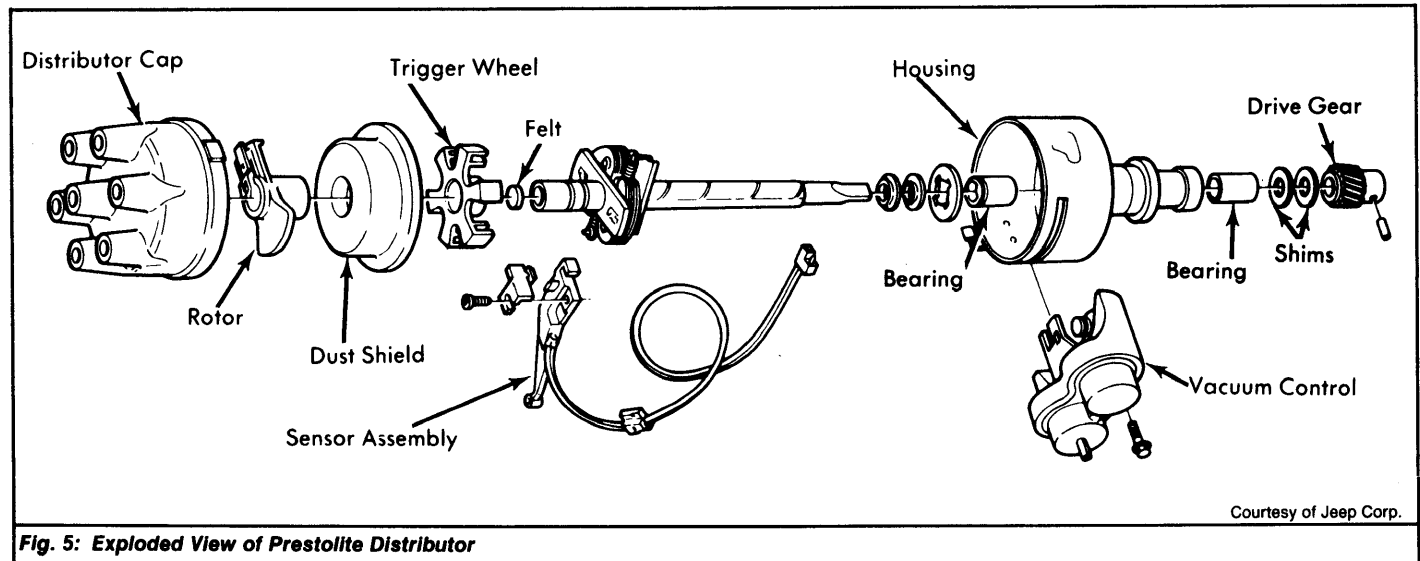

Fig. 5: Exploded View of Prestolite Distributor