

4-26 1975-79 DISTRIBUTORS & IGNITION SYSTEMS

Motorcraft Dura-Spark II Ignition System

1977-79 Ford Motor Co.

DESCRIPTION

Motorcraft Dura-Spark II ignition is basically the same as the Solid State Ignition (SSI) system used in previous years. The higher secondary voltage output of the basic Dura-Spark II system requires a new distributor terminal housing (cap) and adapter, a larger rotor, larger spark plug cables and wider spark plug gaps. Other components in the system include the Electronic Control Module (ECM) and oil filled coil.

OPERATION

When ignition switch is on, current is supplied to the coil through a 1.35 ohm primary resistance wire. As distributor shaft rotates, the distributor generates signals causing module to break the primary current and induce secondary voltage in coil. A timing circuit in module turns primary circuit on again to energize coil for next spark cycle. The dwell varies with engine speed and cannot be changed.

Electronic Control Module - The module uses 6 wires. The Red and White wires are ignition feed. The White wire is ignition primary circuit with engine cranking and Red is ignition primary (1.35 ohms resistance) with engine running. The primary current is turned on and off by the control unit through the Green wire between module and coil. The Orange and Purple wires transmit signal to the module from the distributor stator/magnetic pick-up coil. The Black/Green wire is the distributor ground circuit.

Distributor - The distributor contains a pick-up coil which produces a magnetic field. The armature turning with the distributor shaft causes the field to collapse. The module senses the make and break of the magnetic field and signals the ignition coil to turn on and off. The distributor cap is large to provide better insulation for the very high secondary voltage.

Ignition Coil - The ignition coil is oil filled and the wire terminals are designed so that interchange with other types of coils is not possible. The "DEC" terminal (Green wire) connects to the ECM. The "BAT" terminal (Red wire) connects to the ignition switch, ballast resistor and the control module.

SYSTEM PRECAUTIONS

- 1) Silicone dielectric grease must be applied to all insulating areas at distributor, coil, and spark plug boots. A 3/4" clearance must be maintained at distributor cap mounting edge, spark plug wire terminals, and coil tower, to prevent high voltage arcking to ground.
- 2) To help prevent radio frequency interference, coat the entire brass rotor tip with silicone dielectric grease to a thickness of about 1/8". Do not remove this grease if discolored, because the grease will maintain its insulating properties.

- 3) When replacing spark plug wires, insure wire made of the same material is used for replacement. Silicone/Silicone wire can be identified by the letters "SS" appearing on the wire in White lettering. Silicone/EPDM wire can be identified by the letters "SE" appearing on the wire in Black lettering. The "SS" wire is used on cylinders subject to very high engine temperatures.

TESTING

SECONDARY IGNITION VOLTAGE CHECK

CAUTION: When checking secondary voltage, do not remove the following spark plug wires while engine is running. No. 3 or 5 on 6-cylinder engines. No. 1 or 8 on V8 engines.

Perform following tests using an oscilloscope with inductive type clamps and follow the scope manufacturers' instructions.

Secondary Voltage Reserve - 1) Clamp secondary voltage pick-up over distributor-to-coil high voltage wire. Run engine at 1000 RPM and check overall operating condition, then check secondary voltage reserve. Reserve should be 28,000 volts minimum. Regardless of reading, continue test.

2) Using an ohmmeter, check resistance of coil-to-distributor cap high voltage wire. Resistance should be 5000 ohms per inch maximum.

Rotor-to-Cap Voltage Drop - Make this test with engine at idle and secondary voltage pick-up connected over coil-to-distributor high voltage wire. Voltage drop from secondary voltage reserve should not exceed 8000 volts. If drop is not to specification, check cap and rotor.

Required Spark Plug Voltage - Make this test with engine at 2000 RPM with secondary voltage pick-up connected over coil-to-distributor high voltage wire. Firing voltage should be relatively even and between 6000-20,000 volts. If firing voltage is not okay, check individual cylinder firing voltage. Each cylinder should receive a minimum of 4000 volts and all cylinders should be within 50% of each other.

Spark Plug Wire Resistance - Check spark plug wire resistance using an ohmmeter. Resistance should not exceed 5000 ohms per inch with spark plug wire connected to the distributor cap and resistance test made through the internal distributor cap terminal.

MODULE BIAS TEST

With ignition on, measure voltage between pin No. 4 (Red wire) and engine ground. If observed voltage is less than battery voltage, repair battery feed wire (Red wire) between ignition switch and control module.

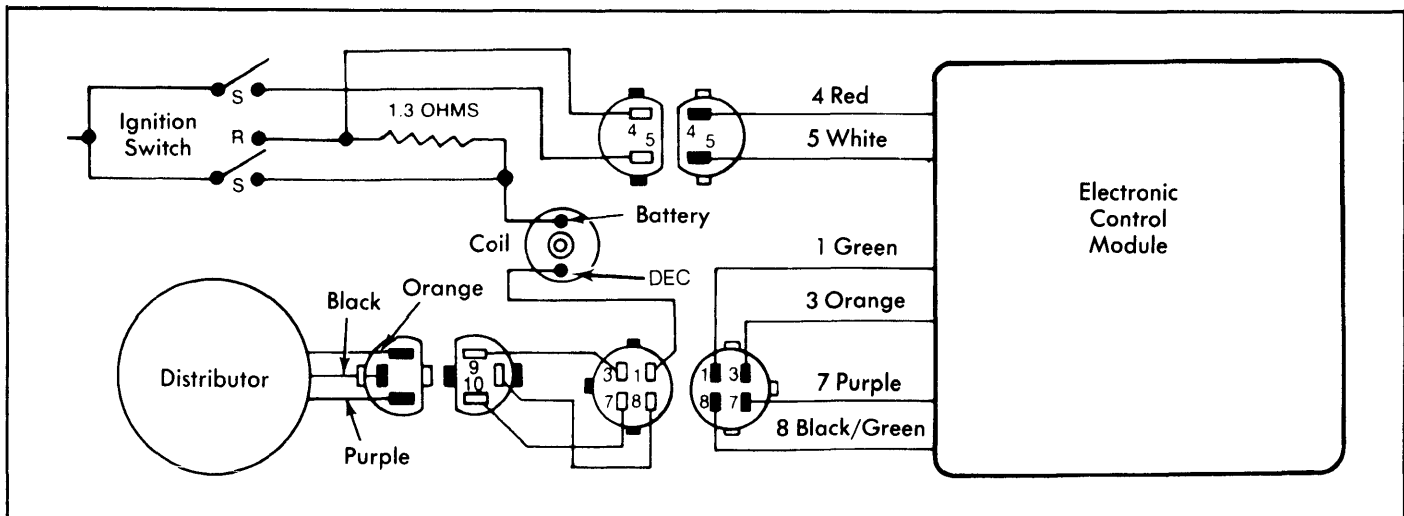

Fig. 1: Motorcraft Dura Spark II Ignition System Wiring Diagram & Connector Terminal Identification

1975-79 DISTRIBUTORS & IGNITION SYSTEMS 4-27

Motorcraft Dura-Spark II Ignition System (Cont.)

BATTERY SOURCE TEST

- 1) Without disconnecting coil, connect voltmeter between coil "BAT" terminal (Red wire) and engine ground. Connect a jumper wire from coil "DEC" terminal (Green wire) to a good ground.
- 2) Turn all lights and accessories off and turn ignition on. A reading of 4.9-7.9 volts indicates primary circuit from battery to coil is satisfactory.

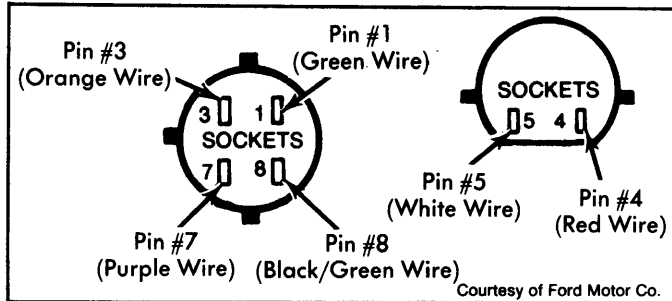

Fig. 2: Dura Spark II Connectors (Harness Side)

- 3) If reading is less than specified, inspect primary wiring for worn insulation, broken strands and loose or corroded terminals. If reading is greater than specified, check and replace resistance wire (if necessary).

CRANKING TEST

With engine cranking, measure voltage from pin No. 5 to engine ground. See Fig. 2. If voltage is not 8-12 volts, repair voltage feed (White) wire to the module.

MAGNETIC PICK-UP (STATOR ASSEMBLY) TEST

With key off, check resistance between pins No. 3 and 7. Reading should be 400-1000 ohms. Check resistance between pin No. 8 and engine ground. Reading should be zero ohms. Check resistance between pin No. 3 and engine ground, and between pin No. 7 and engine ground. Both readings should be more than 70,000 ohms. If any of the above tests fail, the distributor magnetic pick-up is defective and must be replaced.

IGNITION COIL TEST

With ignition off, check secondary resistance between pin No. 4 and coil tower. Resistance should be 7700-9300 ohms. Check primary resistance between pins No. 1 and 4. Resistance should be 1.13-1.23 ohms. If coil resistance is not within limits, bench test coil using standard testing procedures.

STARTING CIRCUIT TEST

Connect jumper between pins No. 1 and 8. Check voltage between coil "BAT" terminal and ground. If reading is less than 6 volts, ignition by-pass circuit is open or grounded. Check all primary circuit connections and wires. Repair or replace parts as required.

SHORT TEST

Check resistance between pin No. 1 and engine ground. If less than 4 ohms, check for short-to-ground at coil primary terminals and in primary wiring to coil. Repair as required.

PRIMARY RESISTANCE WIRE TEST

Resistance between pin No. 4 and coil battery terminal should be 0.7-1.7 ohms. If not within specifications, check and/or replace ignition resistance wire.

OVERHAUL

DISTRIBUTOR

Disassembly - 1) Remove distributor cap and rotor. Disconnect distributor harness plug. Using a small gear puller or 2 screwdriv-

ers, lift or pry armature from advance plate sleeve and remove roll pin. Remove wire retaining clip, then remove snap ring securing vacuum advance link to pick-up assembly.

2) Remove pick-up assembly retaining screws and lift assembly from distributor. Lift vacuum advance arm from pick-up assembly and position against distributor housing. Remove vacuum advance diaphragm unit. Remove attaching screws and lift base plate assembly from distributor.

Reassembly - Reverse disassembly procedure, being sure to coat brass surface of rotor with silicone grease.

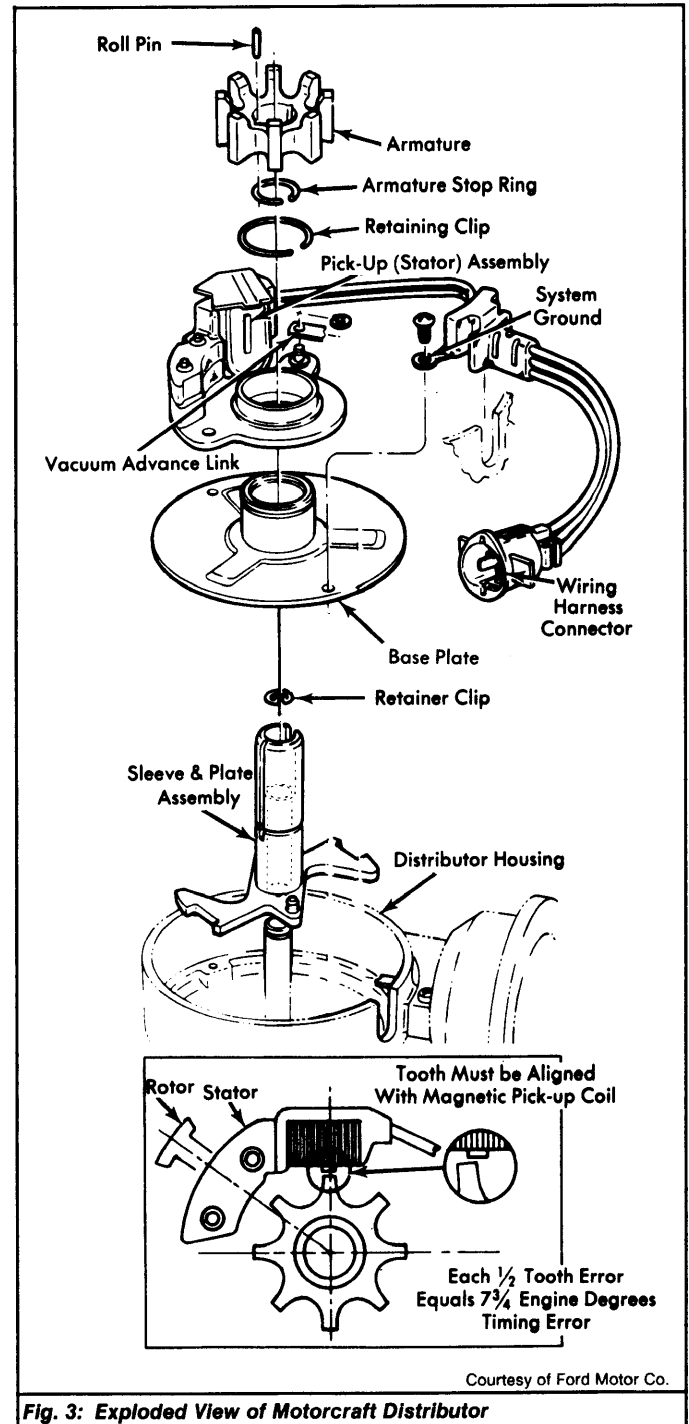

Fig. 3: Exploded View of Motorcraft Distributor