

1975-79 EXHAUST EMISSION SYSTEMS

Jeep Transmission Controlled Spark

3-203

1975-78 Models

DESCRIPTION & OPERATION

Transmission Controlled Spark (TCS) system reduces the emission of oxides of nitrogen (NO_x) by lowering peak combustion temperature. TCS system consists of a solenoid vacuum valve located at right rear of intake manifold (V8 engines) or on a bracket at rear of intake manifold (6-cylinder engines), a solenoid control switch located at the transmission, and a Coolant Temperature Override (CTO) switch located at the thermostat housing (V8 engines) or left rear side of block (6-cylinder engines).

SOLENOID VACUUM VALVE

No vacuum advance occurs when valve is energized. With valve energized, carburetor ported vacuum (manifold vacuum on 6 cylinder CJ models) is blocked and distributor vacuum hose is vented to atmosphere. Vacuum advance occurs when valve is de-energized. When valve is de-energized, distributor vacuum vent to atmosphere is closed and vacuum is allowed to distributor.

SOLENOID CONTROL SWITCH

Switch opens or closes in relation to transmission gear position (vehicle speed on automatic transmission models). In high gear (manual transmission) or vehicle speed over 34-38 MPH (automatic transmission), switch opens and breaks ground circuit to the solenoid vacuum valve.

In low gear ranges (manual transmissions), or vehicle speed less than 22-28 MPH (automatic transmission), switch is closed and completes the ground circuit to solenoid vacuum valve. Switch is operated by shifter shaft of manual transmission models, and by speed sensor mounted in the speedometer cable on automatic transmission models.

COOLANT TEMPERATURE OVERRIDE (CTO) SWITCH

When coolant temperature is below 160°F, CTO allows intake manifold vacuum to the distributor vacuum advance diaphragm. When coolant temperature reaches 160°F, CTO stops intake manifold vacuum and allows carburetor ported vacuum to distributor vacuum advance diaphragm.

TESTING

TCS SYSTEM

- 1) With ignition switch on, disconnect wire connector from solenoid vacuum valve. Connect wire lead of test light to ground and touch test light probe to each terminal of connector. Test light should glow at one of the terminals, if not, ignition portion of TCS system is defective.
- 2) With transmission in Neutral, connect wire lead of test light to battery positive post. Touch probe end to solenoid vacuum valve ground wire terminal at connector which made light glow in previous test. Test light should glow. If test light does not glow, go to next step.
- 3) Disconnect wire at solenoid control switch. Connect one end of a jumper wire to switch wire connector and other end to ground. If test light glows when jumper wire is grounded, solenoid control switch is defective. If light does not glow, control switch wire is defective.
- 4) Disconnect vacuum hose from vent side of solenoid vacuum valve. Connect vacuum gauge to solenoid vacuum valve where hose was disconnected. Start engine. With solenoid vacuum valve attached, no vacuum should be present. If vacuum is present, replace solenoid vacuum valve.
- 5) Disconnect wires from solenoid vacuum valve. Ported vacuum (manifold vacuum on 6-cylinder CJ models) should be present, if not replace solenoid vacuum valve. Place transmission in high gear

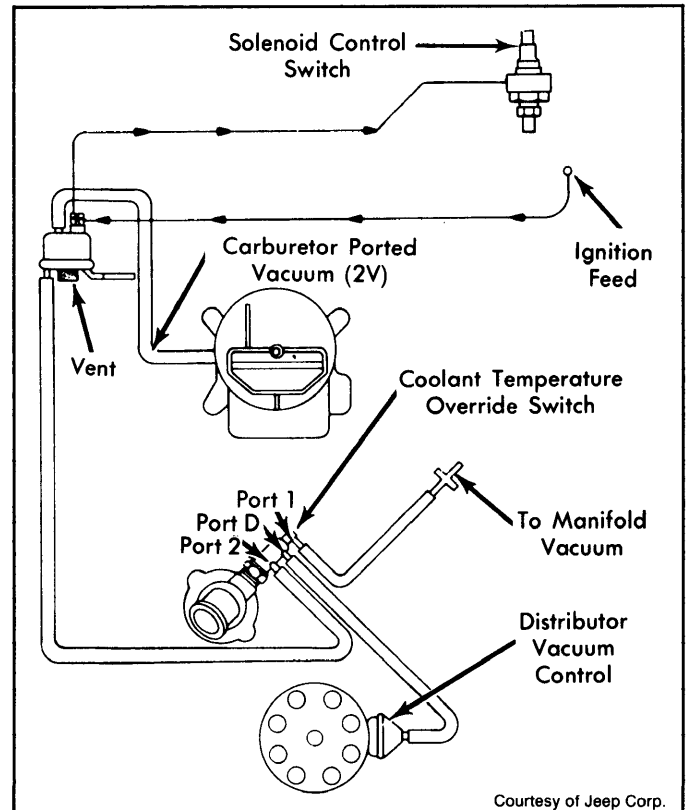

Fig. 1: Typical V8 TCS System

position (manual transmission), raise drive wheels and operate vehicle over 38 MPH (automatic transmission), test light should go out. If test light continues to glow, solenoid control switch is defective and must be replaced.

COOLANT TEMPERATURE OVERRIDE (CTO) SWITCH

- 1) Ensure coolant temperature is below 160°F. Remove all vacuum hoses from CTO switch. Plug hoses that cause vacuum leak. Connect a vacuum hose from a manifold vacuum source to carburetor port of CTO. Connect vacuum gauge to manifold port of CTO. See Fig. 2.
- 2) Start engine. Manifold vacuum should be present on vacuum gauge. If not, replace CTO switch. With engine still running and coolant temperature above 160°F, vacuum should NOT be present at gauge. If vacuum is present, replace CTO switch.

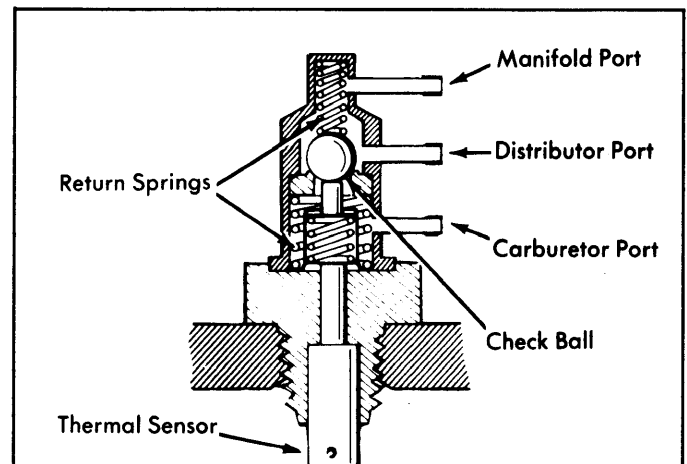

Fig. 2: Coolant Temperature Override CTO Switch