

# 1975-79 EXHAUST EMISSION SYSTEMS

## 1978 General Motors Vacuum Diagrams

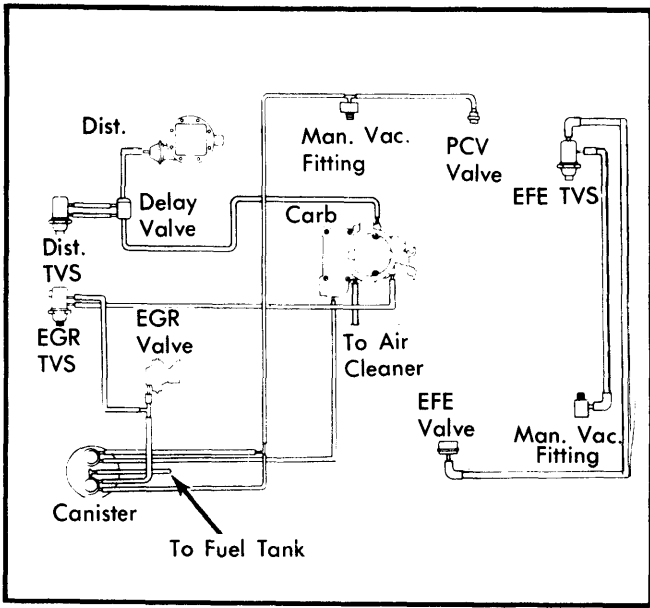

**Fig. 1 Vacuum Hose Schematic for 250" Federal Light Duty Emission System**

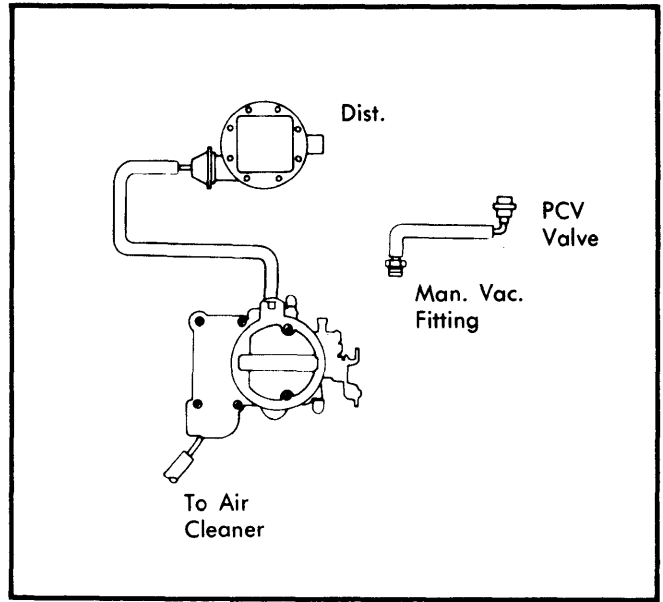

**Fig. 3 Vacuum Hose Schematic for 250" & 292" Federal Heavy Duty Emission System**

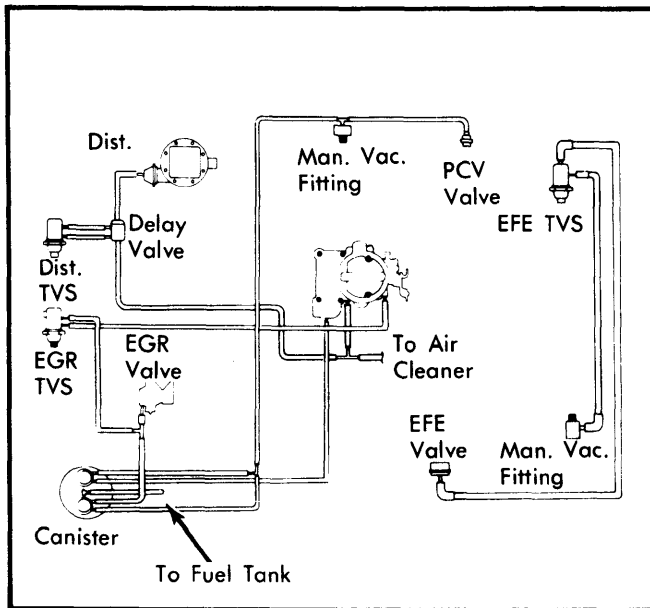

**Fig. 2 Vacuum Hose Schematic for 250" Calif. Light Duty Emission System**

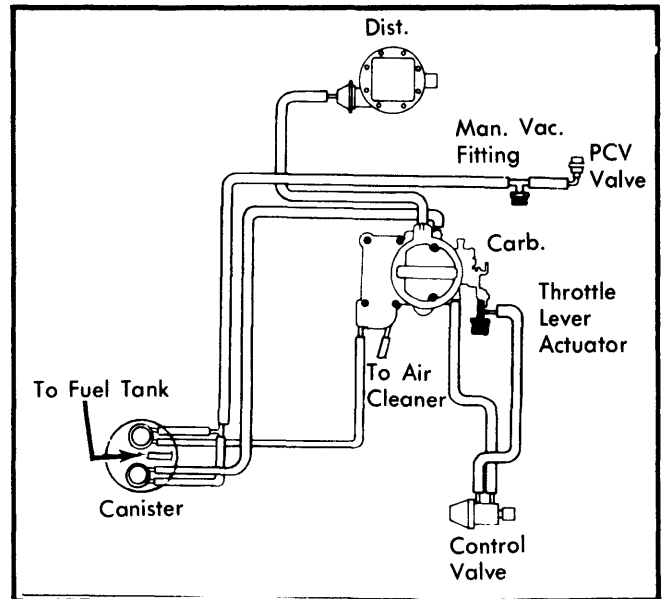

**Fig. 4 Vacuum Hose Schematic for 292" Calif. Heavy Duty Emission System**

# 1975-79 EXHAUST EMISSION SYSTEMS

## 1978 General Motors Vacuum Diagrams (Cont.)

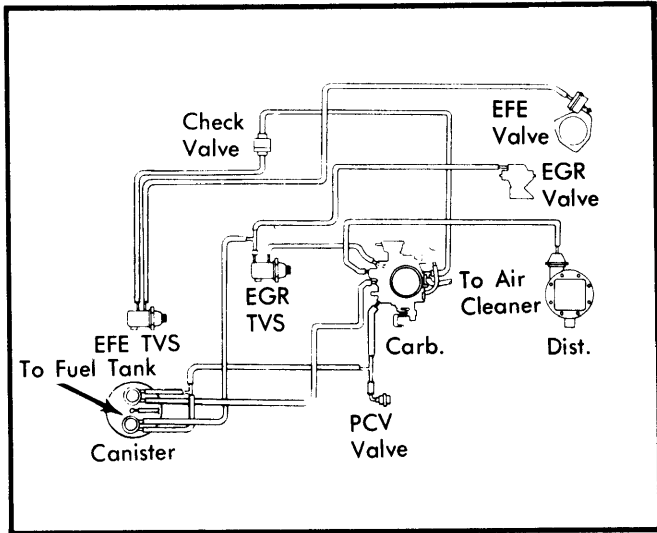

**Fig. 5 Vacuum Hose Schematic for 305" Low Altitude Light Duty Emission System**

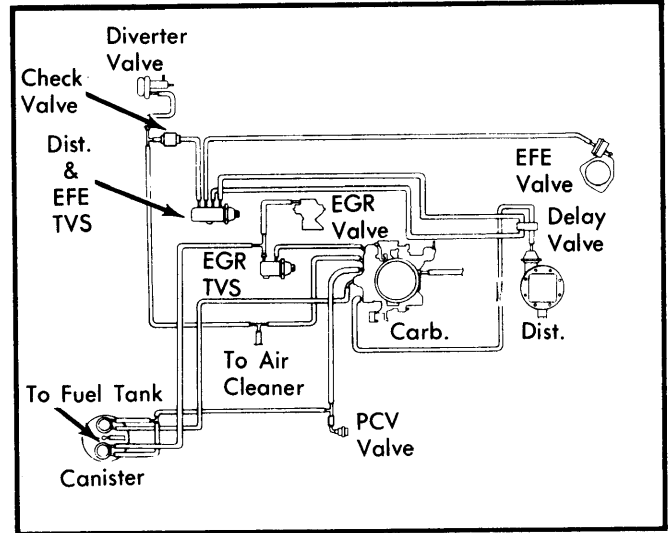

**Fig. 8 Vacuum Hose Schematic for 350" Calif. Light Duty Emission System**

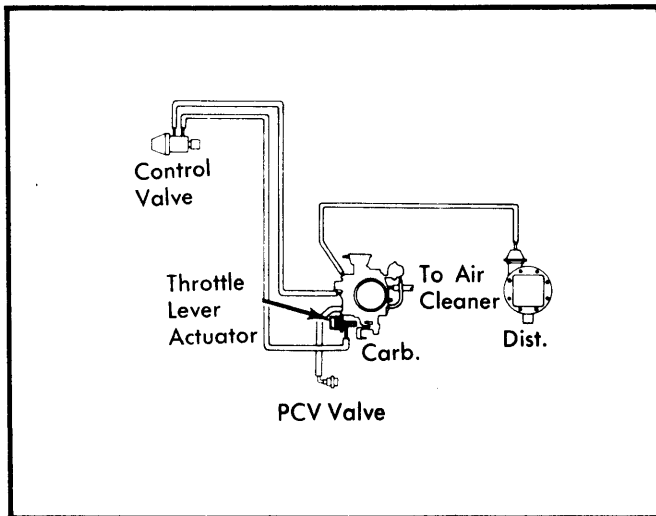

**Fig. 6 Vacuum Hose Schematic for 305" Heavy Duty Emission System**

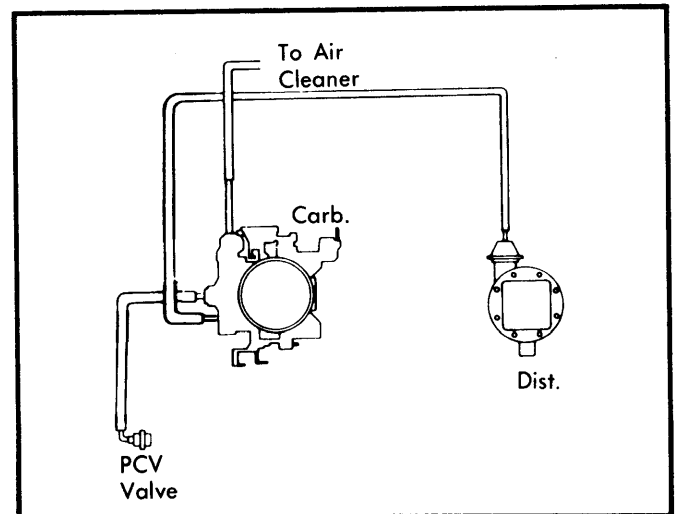

**Fig. 9 Vacuum Hose Schematic for 350" & 400" Light Duty Emission System (W/O A/C)**

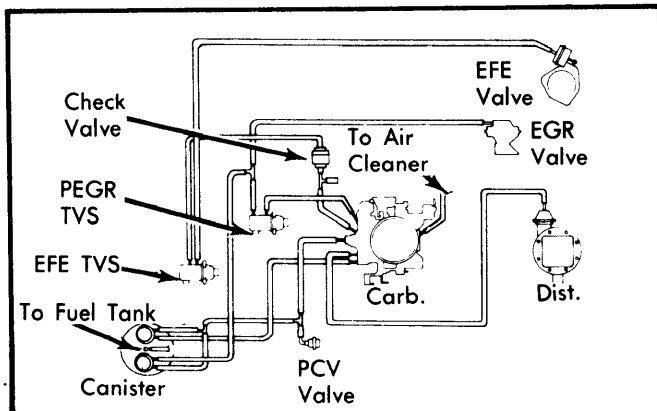

**Fig. 7 Vacuum Hose Schematic for 350" Low Altitude Light Duty Emission System**

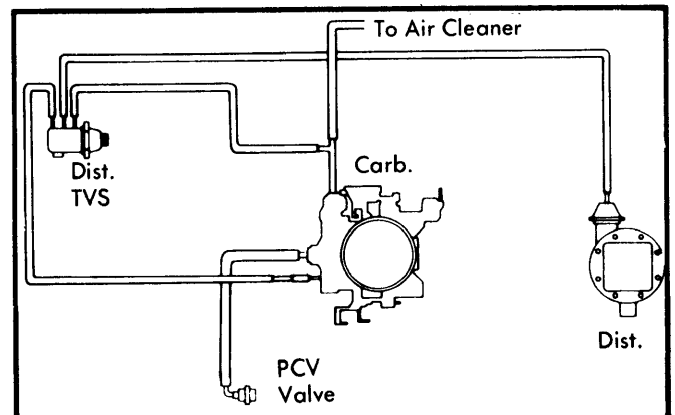

**Fig. 10 Vacuum Hose Schematic for 350" & 400" Heavy Duty Emission System (W/A/C)**

# 1975-79 EXHAUST EMISSION SYSTEMS

## 1978 General Motors Vacuum Diagrams (Cont.)

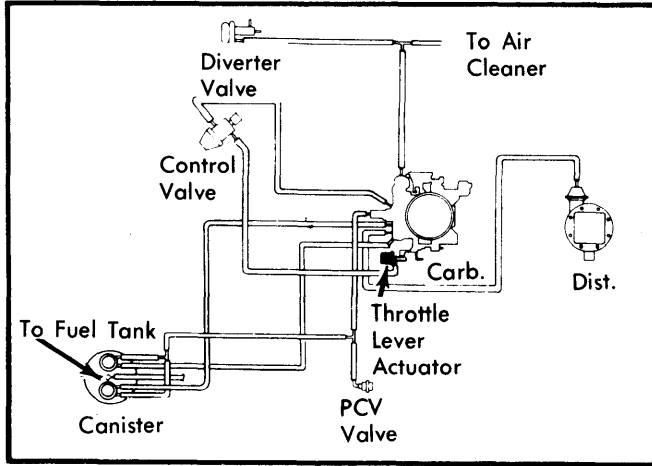

**Fig. 11 Vacuum Hose Schematic for 350" & 400" Calif. Heavy Duty Emission System (W/O A/C)**

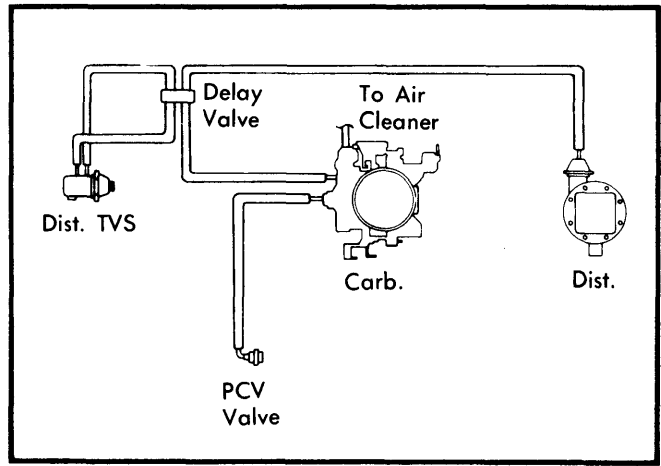

**Fig. 14 Vacuum Hose Schematic for 454" Federal Heavy Duty Emission System**

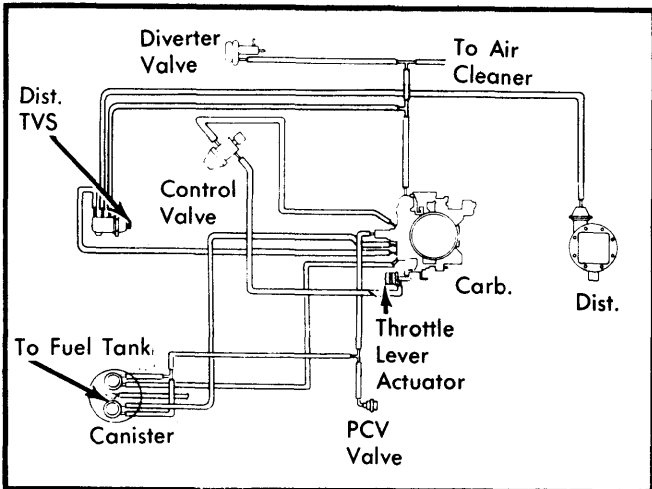

**Fig. 12 Vacuum Hose Schematic for 350" & 400" Calif. Heavy Duty Emission System (W/A/C)**

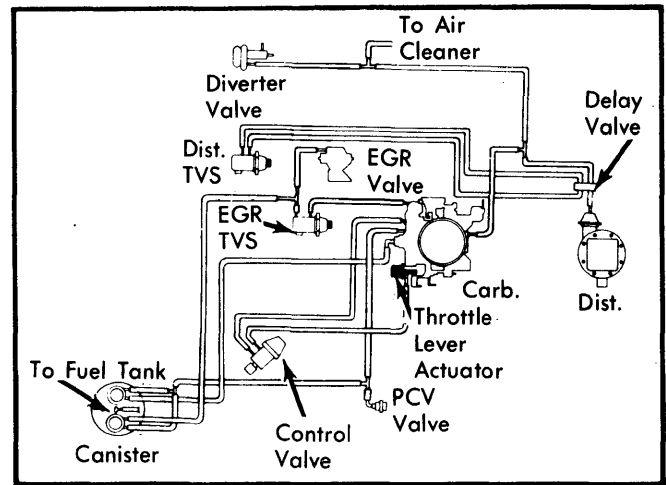

**Fig. 15 Vacuum Hose Schematic for 454" Calif. Heavy Duty Emission System**

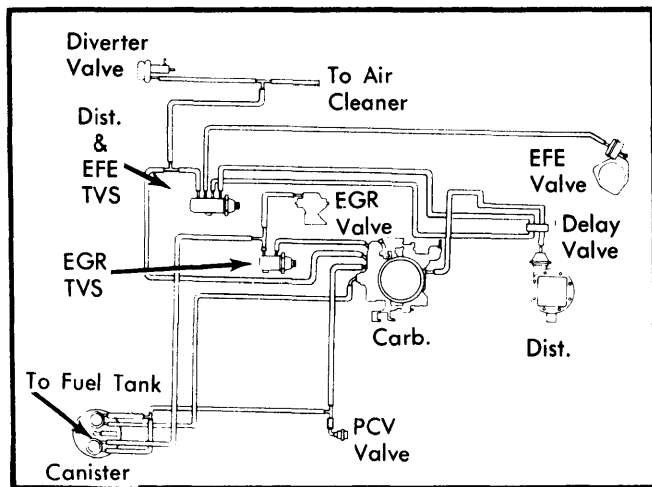

**Fig. 13 Vacuum Hose Schematic for 454" Light Duty Emission System**

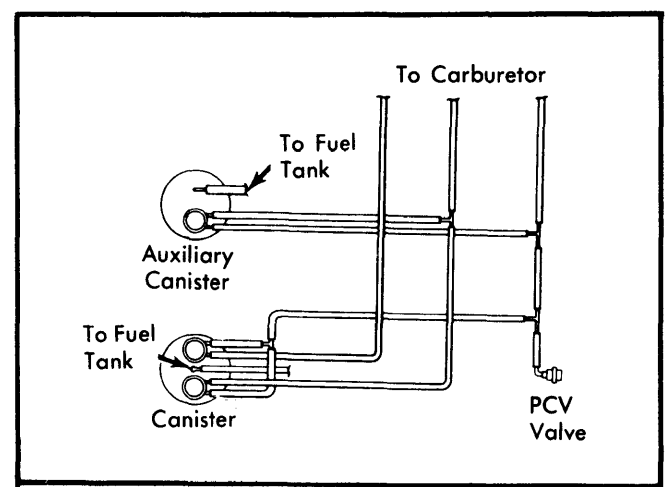

**Fig. 16 Vacuum Hose Schematic for All Trucks with Two Canister System**