

# 1975-79 EXHAUST EMISSION SYSTEMS 1976 General Motors Vacuum Diagrams

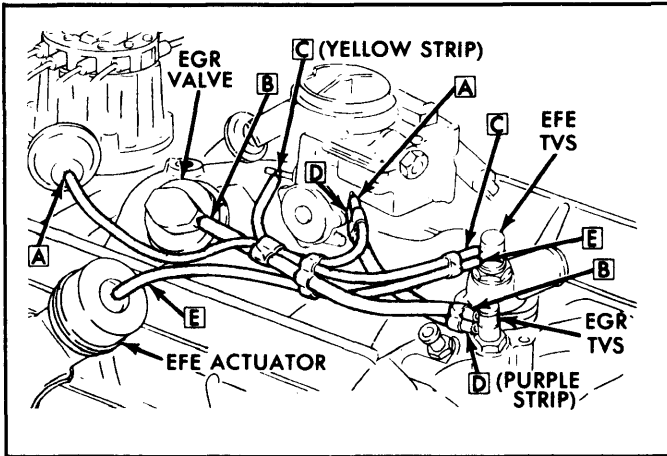

Fig. 1: Federal Light Duty 350" V8 2-Bbl. (2WD)

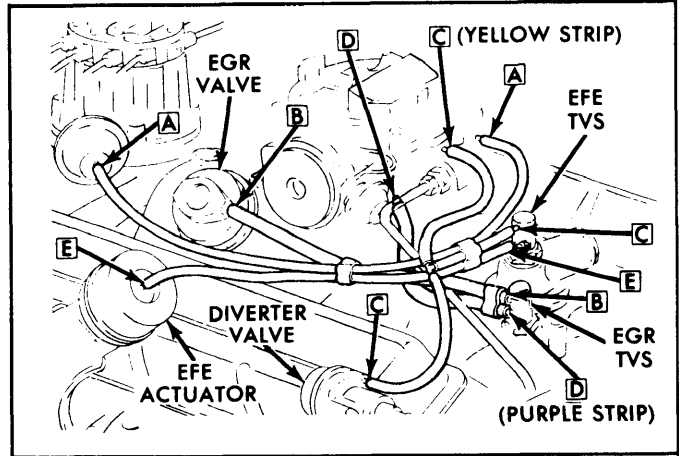

Fig. 4: Federal Light Duty Pickup 350" V8 4-Bbl. (2WD With Air Injection Reactor)

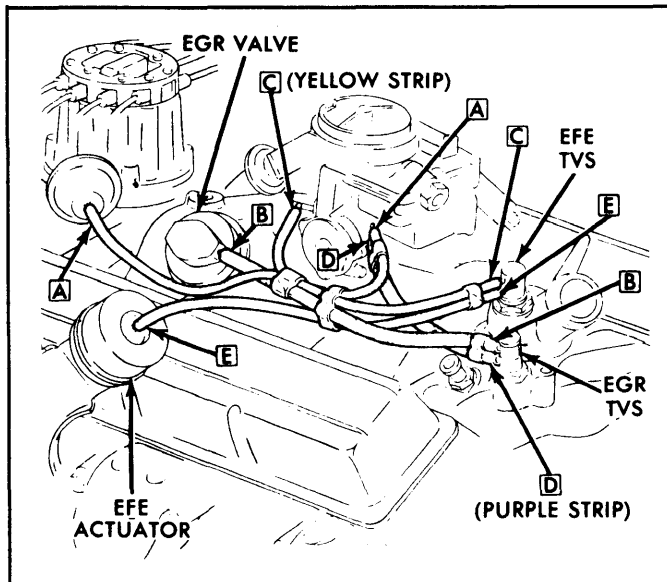

Fig. 2: Federal Light Duty Van 350" V8 2-Bbl.

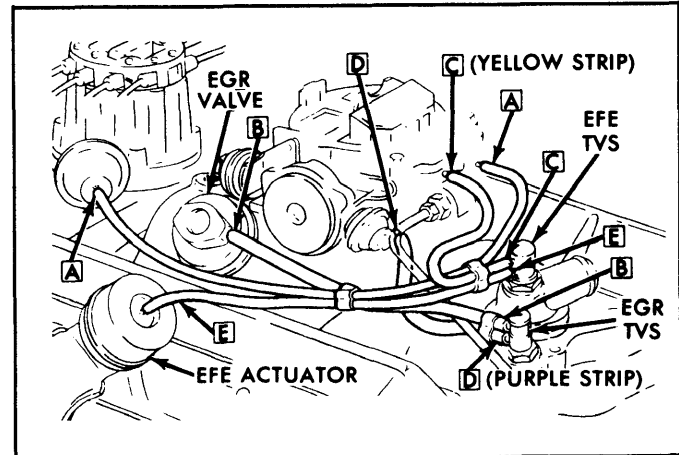

Fig. 5: Federal Light Duty Pickup 350" V8 4-Bbl. (2WD Without Air Injection Reactor)

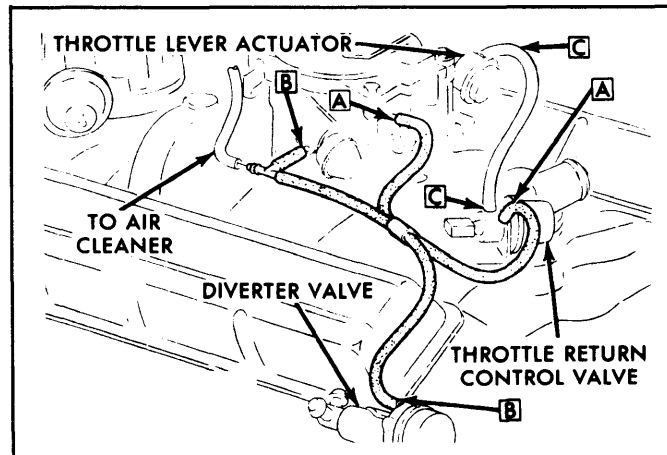

Fig. 3: California Pickup 350" & 400" V8 (2WD) & Heavy Duty California Step Van 350" V8

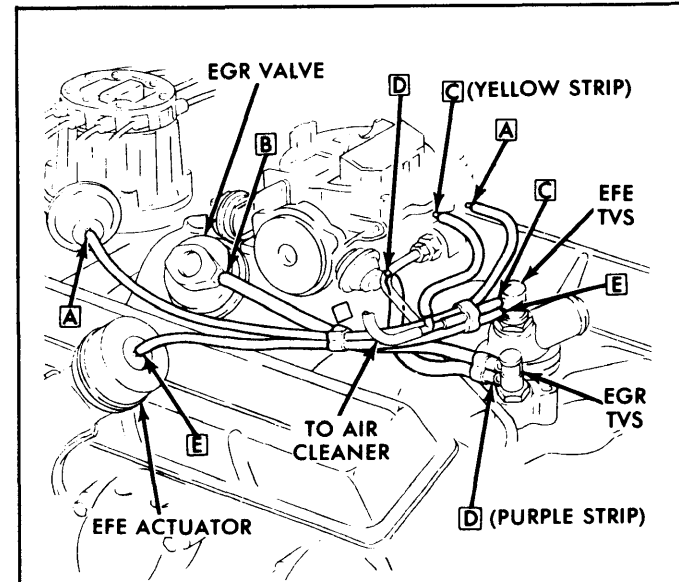

Fig. 6: Federal Light Duty Pickup 350" V8 4-Bbl. (4WD)

# 1975-79 EXHAUST EMISSION SYSTEMS

## 1976 General Motors Vacuum Diagrams (Cont.)

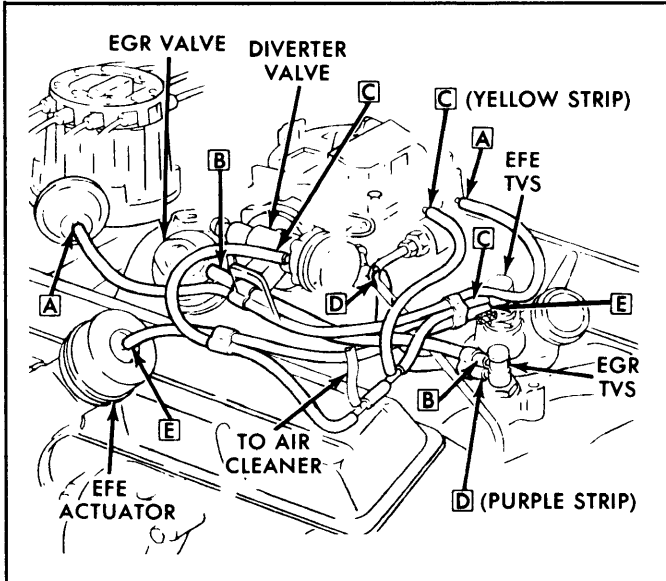

Fig. 7: California Light Duty Pickup 350" V8 4-Bbl. (4WD)

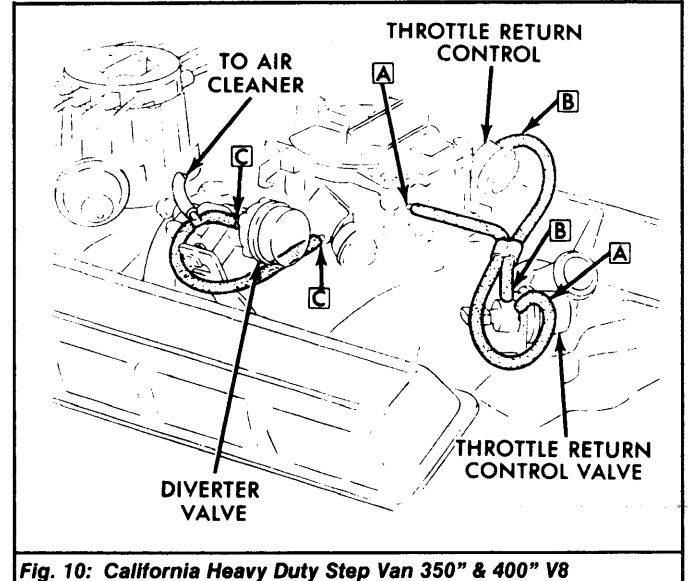

Fig. 10: California Heavy Duty Step Van 350" & 400" V8

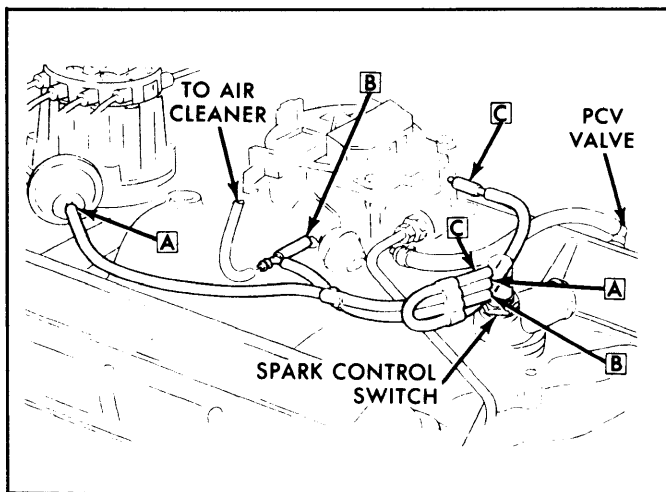

Fig. 8: Federal Light & Heavy Duty Pickup 400" V8 (4WD Without Air Injection Reactor)

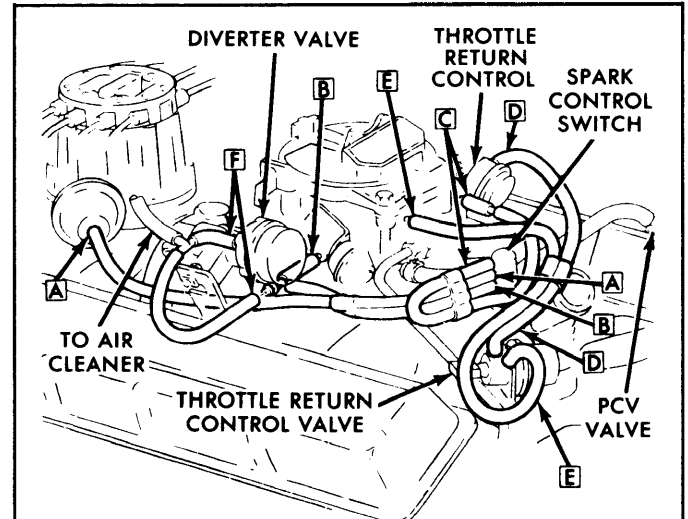

Fig. 11: California Heavy Duty Step Van 400" V8

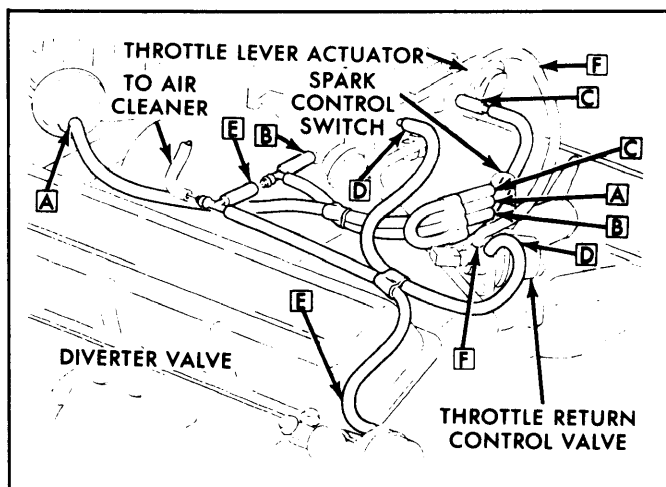

Fig. 9: California Light & Heavy Duty Pickup 400" V8 (4WD)

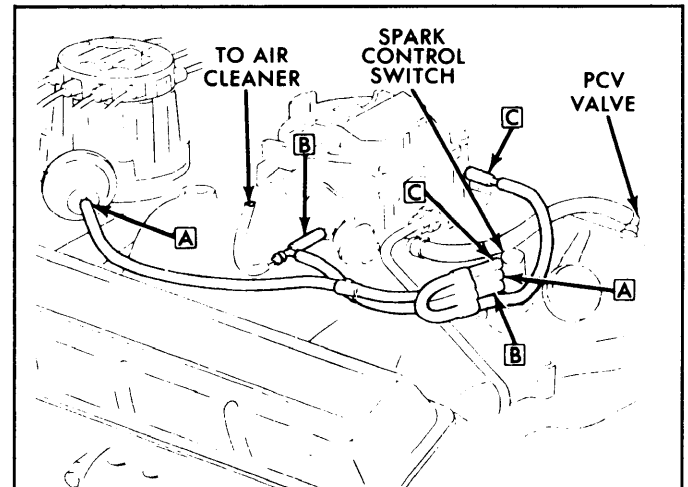

Fig. 12: Federal Heavy Duty Step Van 400" V8

# 1975-79 EXHAUST EMISSION SYSTEMS

## 1976 General Motors Vacuum Diagrams (Cont.)

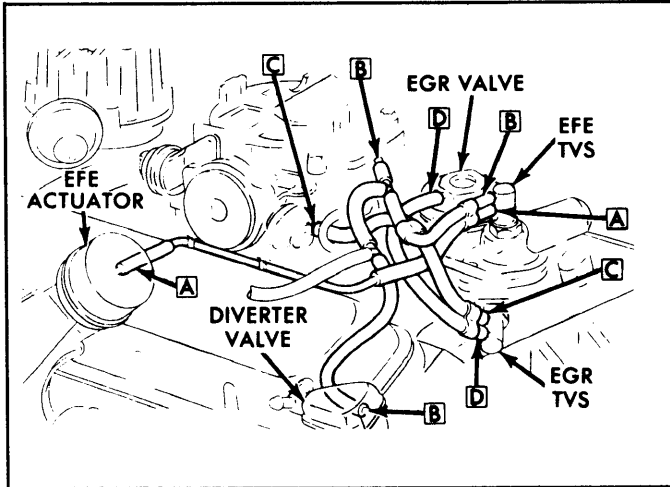

Fig. 13: Federal Light Duty Pickup 454" V8

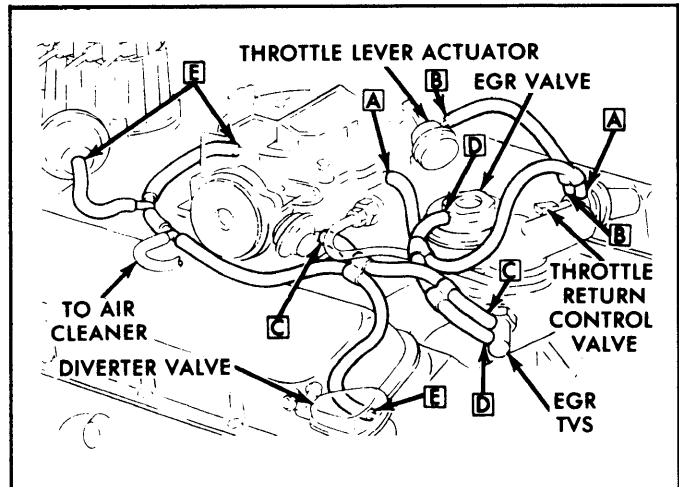

Fig. 14: California Light & Heavy Duty Pickup 454" V8 (2WD) & California Heavy Duty Step Van 454" V8