

# 1975-79 EXHAUST EMISSION SYSTEMS

## 1978 Ford Motor Co. Vacuum Diagram Index

Fig. No.	Calibration	Vehicle
1	8-51L R0	E100, 300" 6 Cyl., Man. Trans., Federal
	8-52L R10	E100, 300" 6 Cyl., Auto. Trans., Federal
	8-51K R0	F100, 300" 6 Cyl., Man. Trans., Federal
	8-51J R0	F100, 300" 6 Cyl., Man. Trans. (4-Speed O.D.), Federal
	8-51M R0	E100, 300" 6 Cyl., Man. Trans. (4-Speed O.D.), Federal
	8-52L R11	E100, 300" 6 Cyl., Auto. Trans., Federal
	8-52U R0	E150, E250, F150, E250, 300" 6 Cyl., Auto. Trans., Calif.
2	8-52K R0	F100, 300" 6 Cyl., Auto. Trans., Federal
	7-77 R10	E150-350, F150-350, 300" 6 Cyl., Man. Trans., Federal
3	7-78 R10	E150-350, F150-350, 300" 6 Cyl., Auto. Trans., Federal
	7-77J R10	E350, F350, 300" 6 Cyl., Man. Trans., Calif.
4	7-78J R1	E350, F350, 300" 6 Cyl., Auto. Trans., Calif.
	8-51J R11	F100, 300" 6 Cyl., Man. Trans. (4-Speed O.D.), Federal
5	8-51K R12	F100, 300" 6 Cyl., Man. Trans., Federal
	8-51L R11	E100, 300" 6 Cyl., Man. Trans., Federal
	8-51M R10	E100, 300" 6 Cyl., Man. Trans., (4-Speed O.D.), Federal
	8-51S R10	F100-250, 300" 6 Cyl., Man. Trans., Calif.
	8-51T R0	E100-250, 300" 6 Cyl., Man. Trans., Calif.
	8-52K R11	F100, 300" 6 Cyl., Auto. Trans., Federal
	8-52U R10	E150, E250, F150, F250, 300" 6 Cyl., Auto. Trans., Calif.
6	8-51T R0	E100-250, 300" 6 Cyl., Man. Trans., Calif.
7	8-52L R12	E100, 300" 6 Cyl., Auto. Trans., Federal
8	8-53G R0	F100, 302" V8, Man. Trans., Federal
9	8-53A R0	F100, 302" V8, Man. Trans., High Alt.
10	8-54G R0	F100, 302" V8, Auto. Trans., Federal
11	7-80 R0	F150, 302" V8, Auto. Trans., Federal
12	8-54S R0	F150, 302" V8, Auto. Trans., Calif.
13	8-53S R0	F100, 302" V8, Man. Trans., Calif.
14	8-54T R10	F100, F150, 302" V8, Auto. Trans., Calif.
15	7-79 R1	F150, 302" V8, Man. Trans., Federal
16	8-59G R1	F100, 351" M V8, Man. Trans., Federal
17	8-60J R0	F100, 351" M V8, Auto. Trans., Federal
18	7-71 R10	F100-350, 351" M V8, Man. Trans., Federal
19	7-72 R11	F100-350, 351" M V8, Auto. Trans., Federal
20	7-71J R10	F350, 351" M V8, Man. Trans., Calif.
21	7-72J R11	F350, 351" M V8, Auto. Trans., Calif.
22	8-60S R11	F100-350, Bronco, 351" M V8, Auto. Trans., Calif.
23	8-59T R3	F100-F250, Bronco, 351" M V8, Man. Trans., Calif.
24	8-60S R0	F100-250, Bronco, 351" M V8, Auto. Trans., Calif.
25	8-60S R12	F100-250, Bronco, 351" M V8, Auto. Trans., Calif.
26	8-60S R13	F100-250, Bronco, 351" M V8, Auto. Trans., Calif.
27	8-64G R0	E100, 351" W V8, Man. Trans., Federal
28	8-65G R0	E100, 351" W V8, Auto. Trans., Federal
29	8-65U R0	E100, 351" W V8, Auto. Trans., Calif.
	8-65S R0	E150, E250, 351" W V8, Auto. Trans., Calif.
30	8-64S R0	E150, E250, 351" W V8, Man. Trans., Calif.
31	7-75A R10	E150, E250, 351" W V8, Man. Trans., Federal
32	7-76A R10	E150-350, 351" W V8, Auto. Trans., Federal
33	7-76J R11	E350, 351" W V8, Auto. Trans., Calif.
34	8-65S R10	E150, E250, 351" W V8, Auto. Trans., Calif.
35	8-65A R0	F100, 351" W V8, Auto. Trans., Federal
36	8-62J R0	F100, 400" V8, Auto. Trans., Federal
37	7-73 R10	F150-350, 400" V8, Man. Trans., Federal
38	7-74 R10	F150-350, 400" V8, Auto. Trans., Federal
39	7-74J R11	F350, 400" V8, Auto. Trans., Calif.
40	8-62T R10	F150, F250, Bronco, 400" V8, Auto. Trans., Calif.
41	8-97 R0	F150-350, 460" V8, Auto. Trans., Federal (W/O AC)
42	8-97 R0	F150-350, E250, E350, 460" V8, Auto. Trans., Federal (W/ AC)
43	8-66U R0	F150, F250, E250, 460" V8, Auto. Trans., Calif.
44	7-97J R0	F350, 460" V8, Auto. Trans., Calif.

# 1975-79 EXHAUST EMISSION SYSTEMS 1978 Ford Motor Co. Vacuum Diagrams

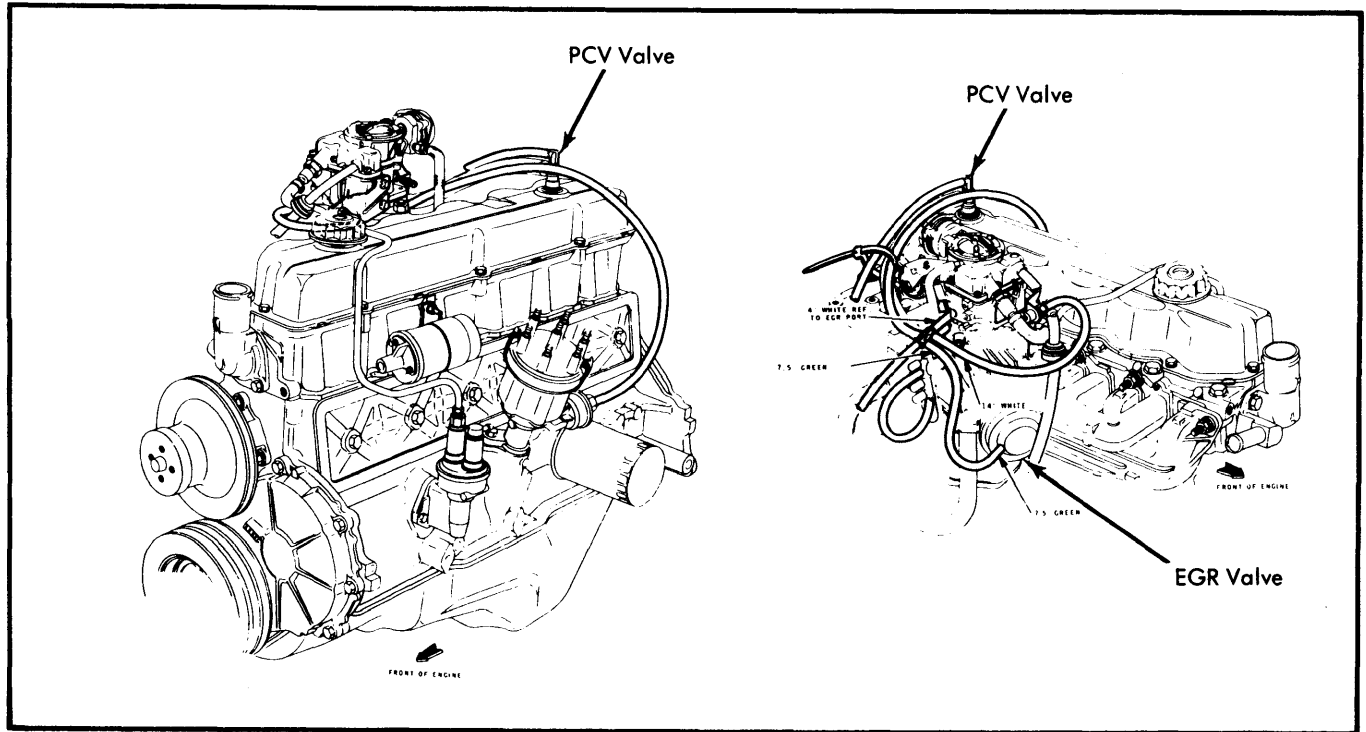

**Fig. 1** 300" 6 Cyl. Pickup & Van, Federal & Calif. with Man. Trans. & Auto. Trans.

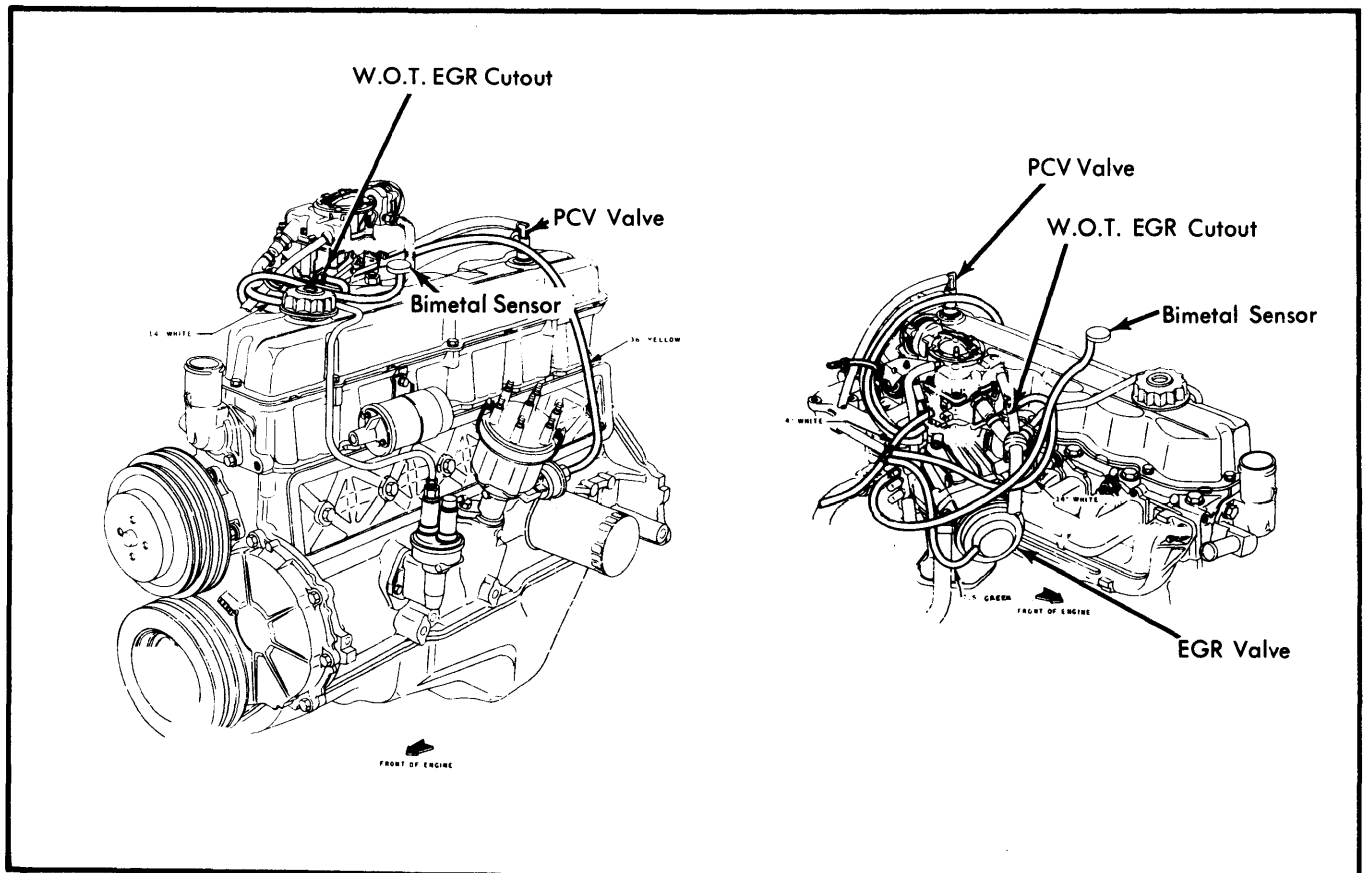

**Fig. 2** 300" 6 Cyl. Pickup, Federal with Auto. Trans.

# 1975-79 EXHAUST EMISSION SYSTEMS

## 1978 Ford Motor Co. Vacuum Diagrams (Cont.)

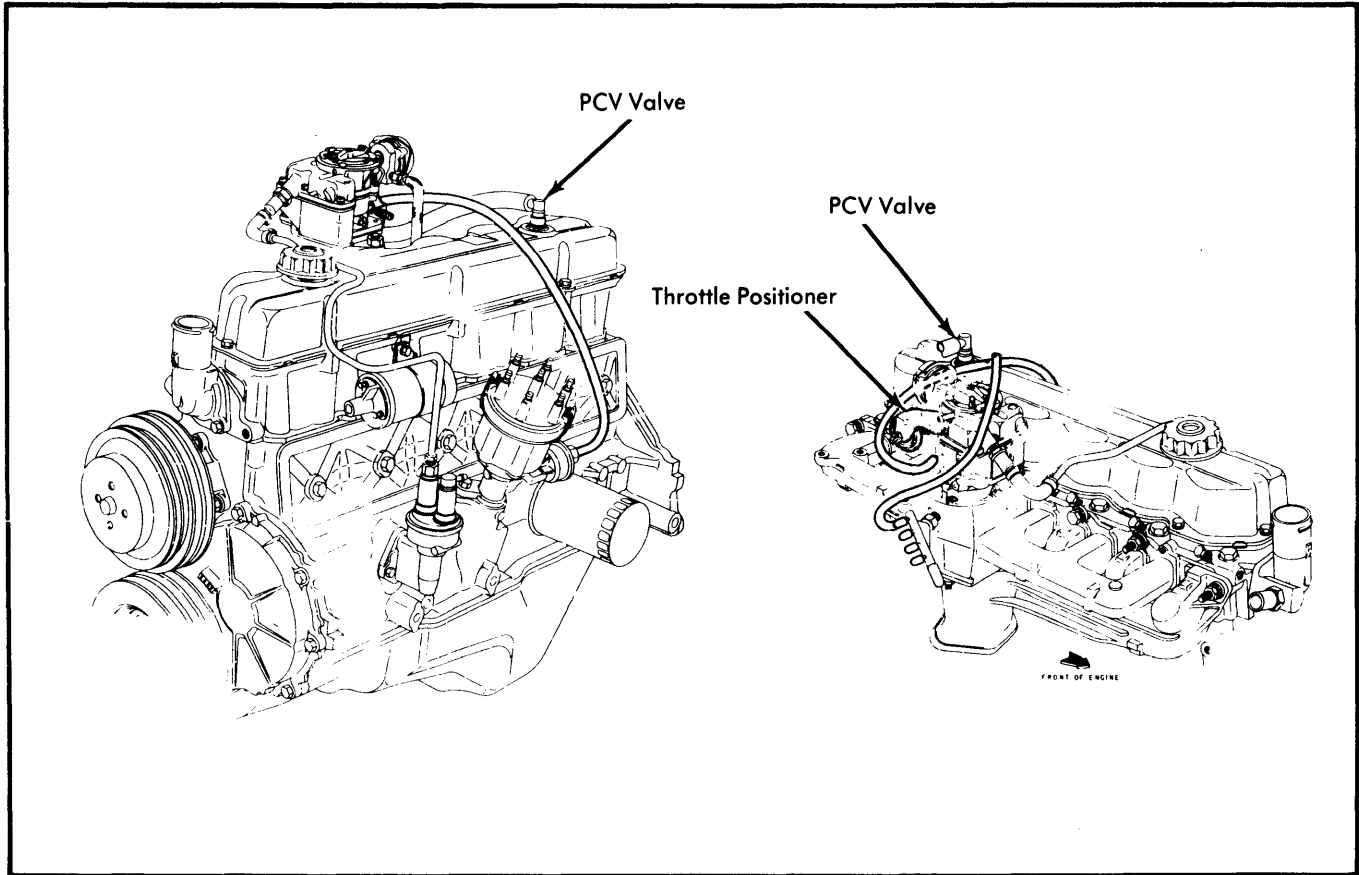

**Fig. 3** 300" 6 Cyl. Pickup & Van, Federal with Man. Trans. & Auto. Trans.

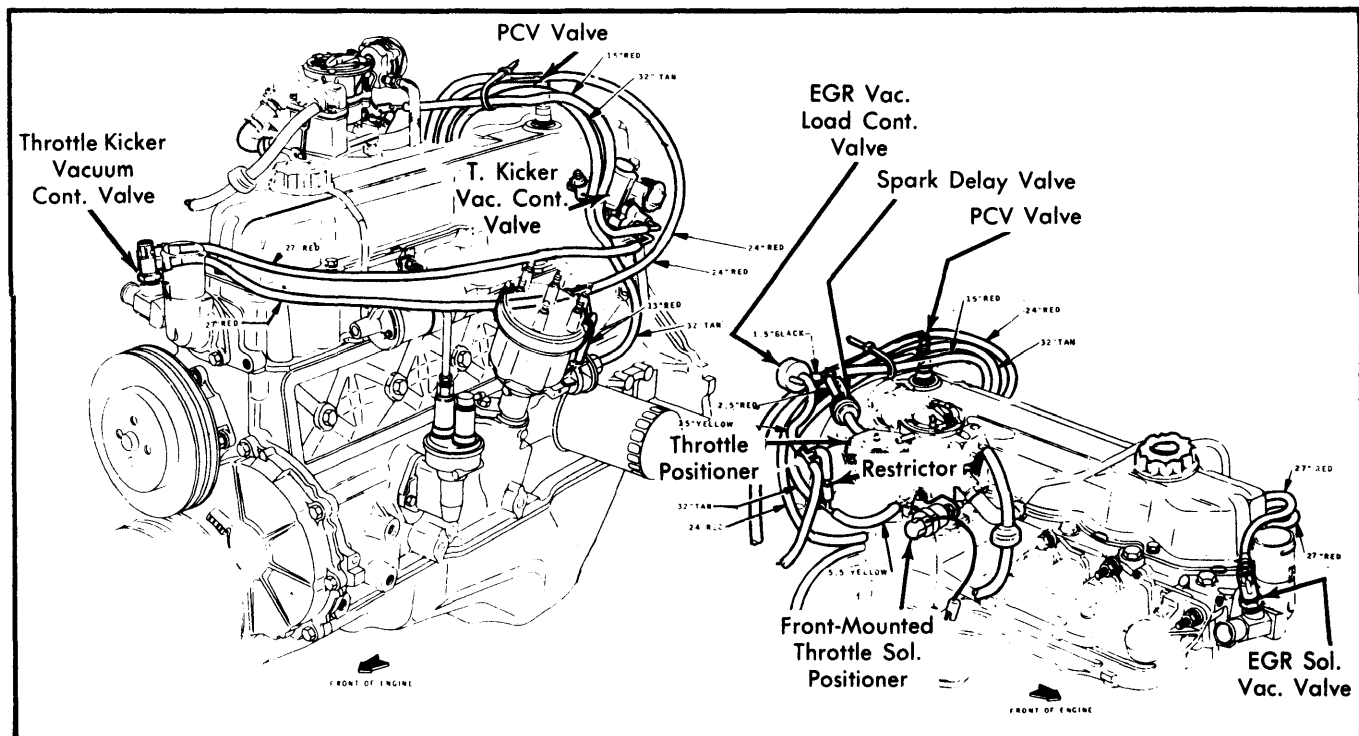

**Fig. 4** 300" 6 Cyl. Pickup & Van, Calif. with Man. Trans. & Auto. Trans.

# 1975-79 EXHAUST EMISSION SYSTEMS

## 1978 Ford Motor Co. Vacuum Diagrams (Cont.)

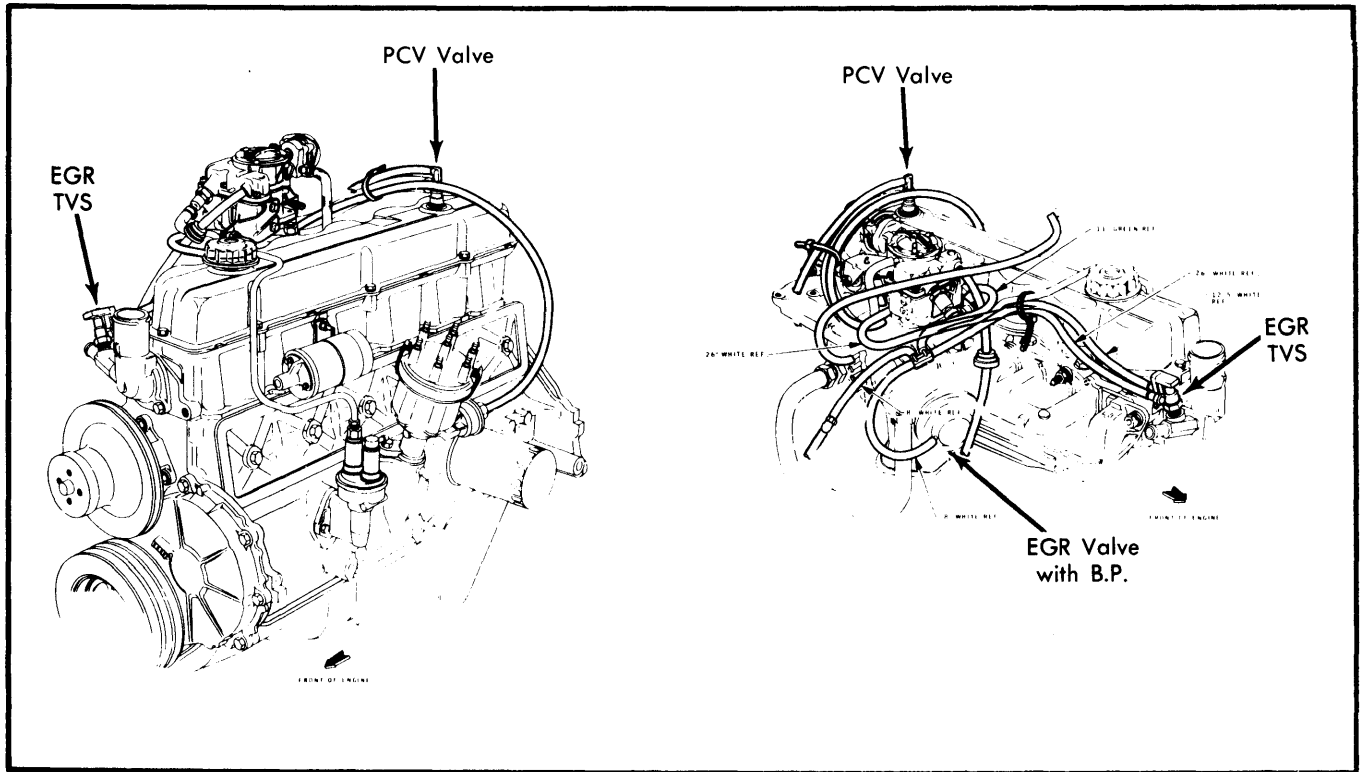

**Fig. 5 300" 6 Cyl. Pickup & Van, Federal & Calif. with Man. Trans. & Auto. Trans.**

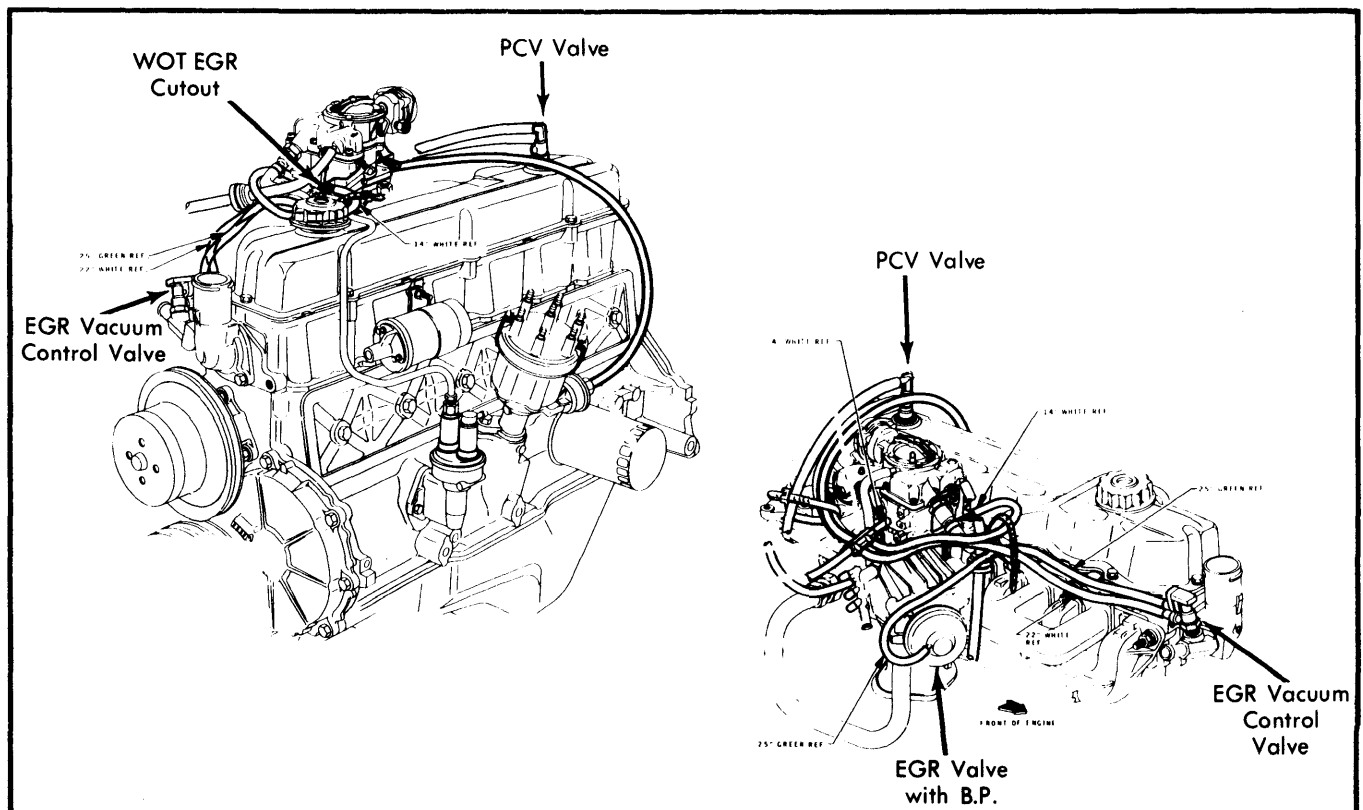

**Fig. 6 300" 6 Cyl. Van, Calif. with Man. Trans.**

# 1975-79 EXHAUST EMISSION SYSTEMS 1978 Ford Motor Co. Vacuum Diagrams (Cont.)

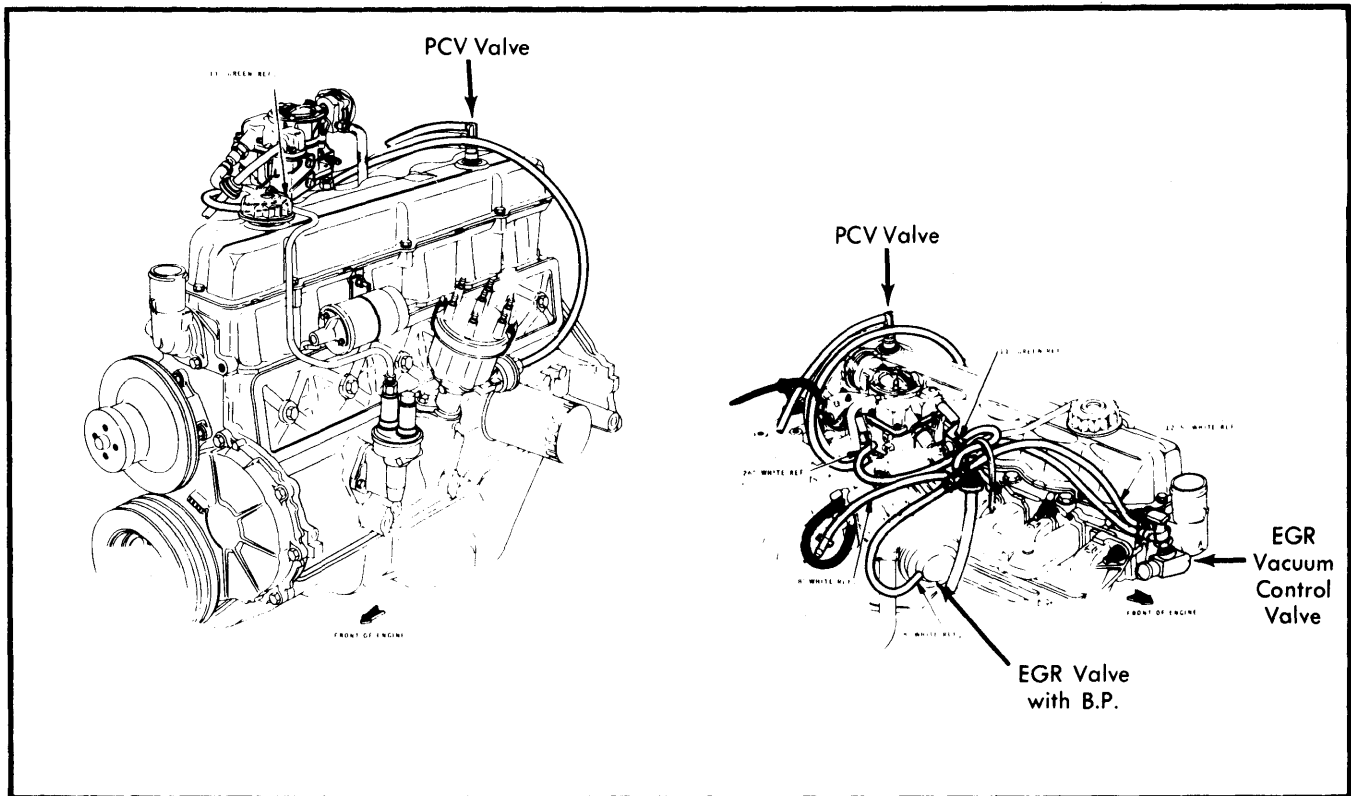

Fig. 7 300" 6 Cyl. Van, Federal with Auto. Trans.

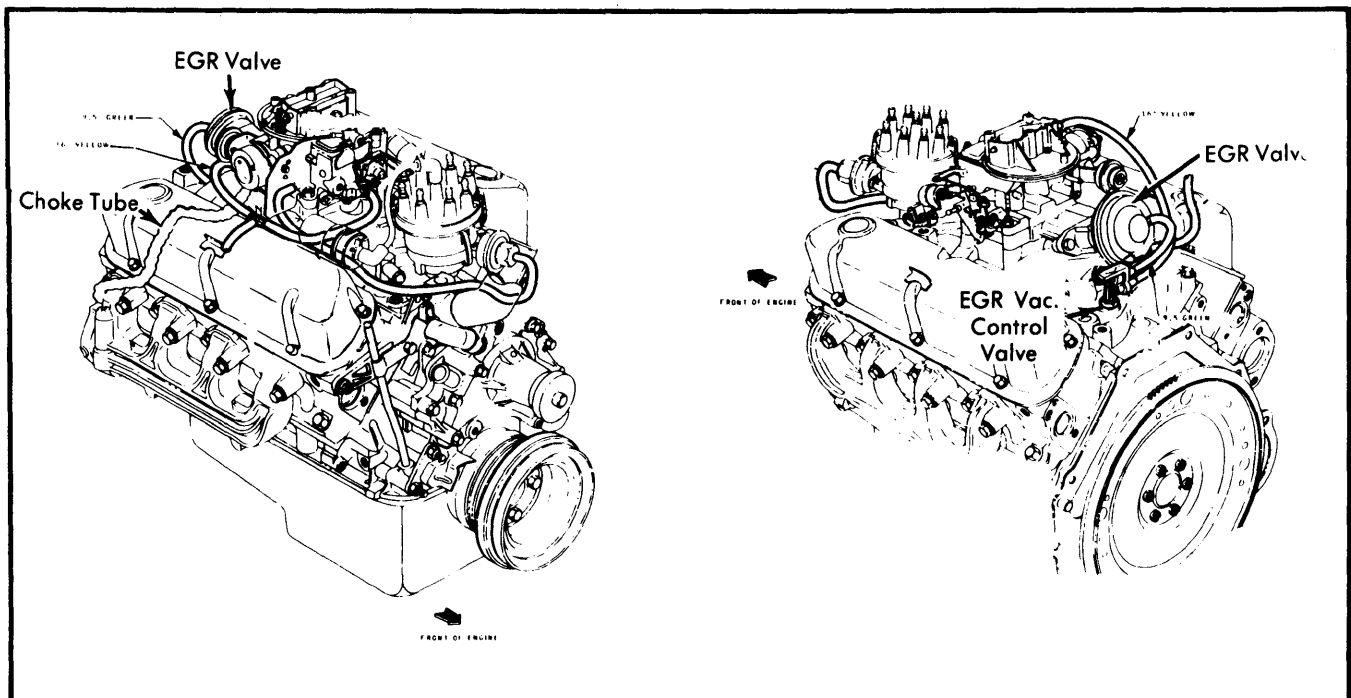
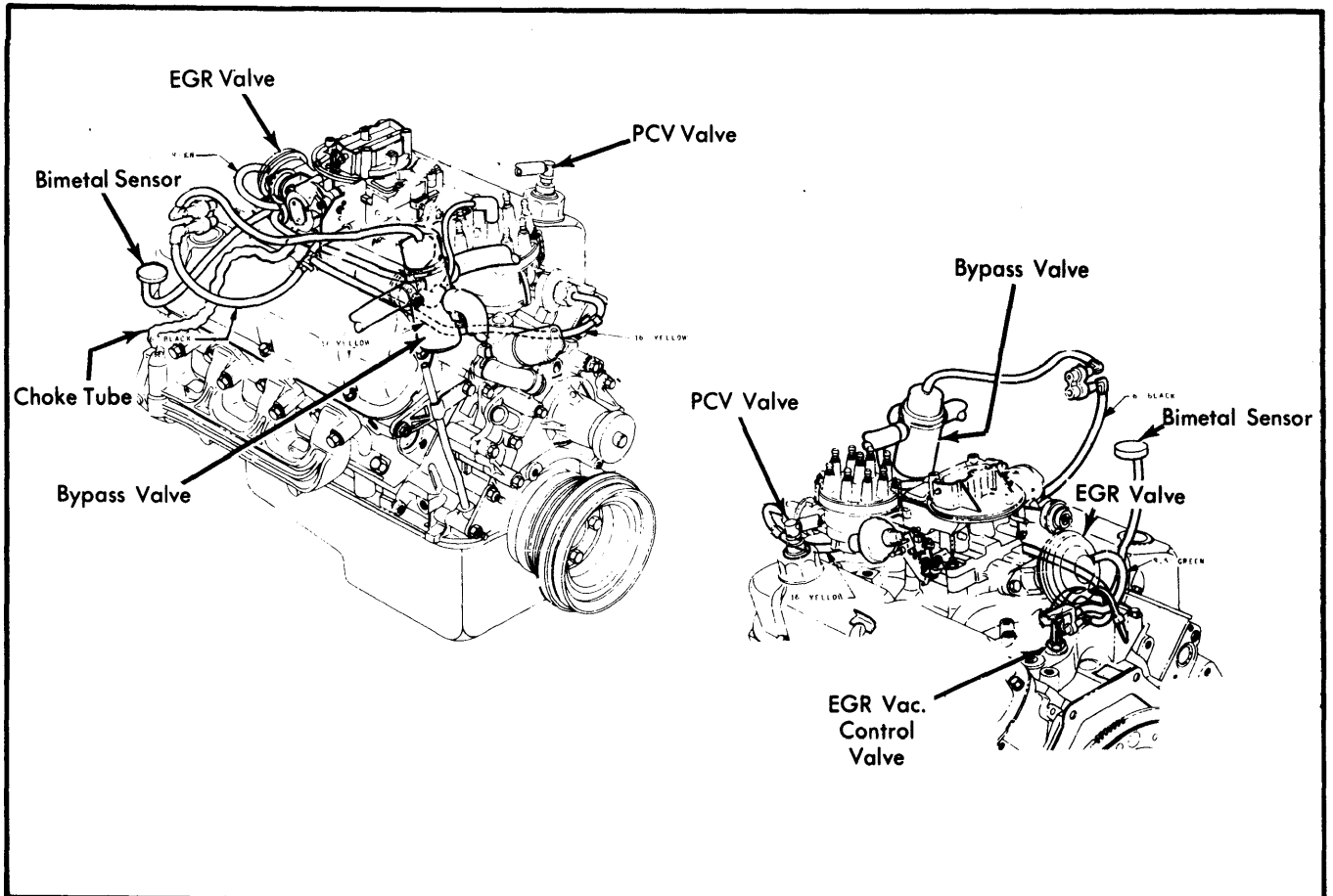

Fig. 8 302" V8 Pickup, Federal with Man. Trans.

# 1975-79 EXHAUST EMISSION SYSTEMS

3-125

## 1978 Ford Motor Co. Vacuum Diagrams (Cont.)



**Fig. 9 302" V8 Pickup, High Alt. with Man. Trans.**

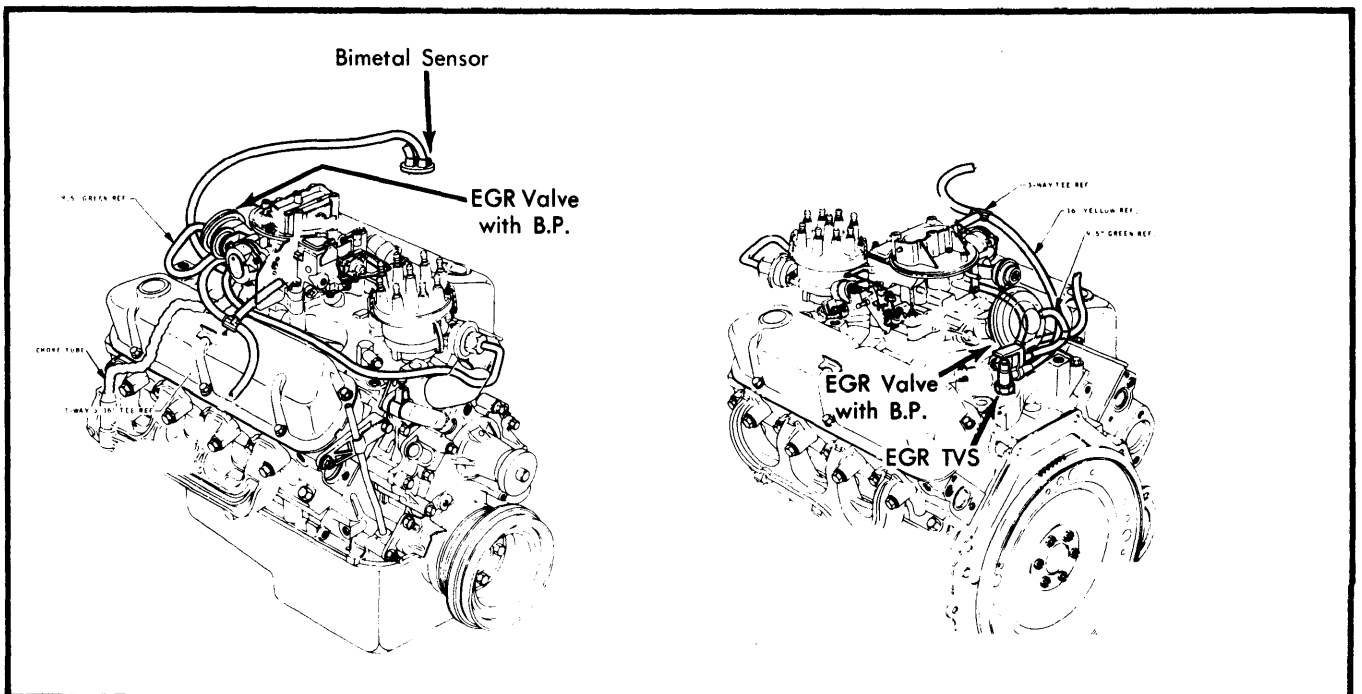

**Fig. 10 302" V8 Pickup, Federal with Auto. Trans.**

# 1975-79 EXHAUST EMISSION SYSTEMS

## 1978 Ford Motor Co. Vacuum Diagrams (Cont.)

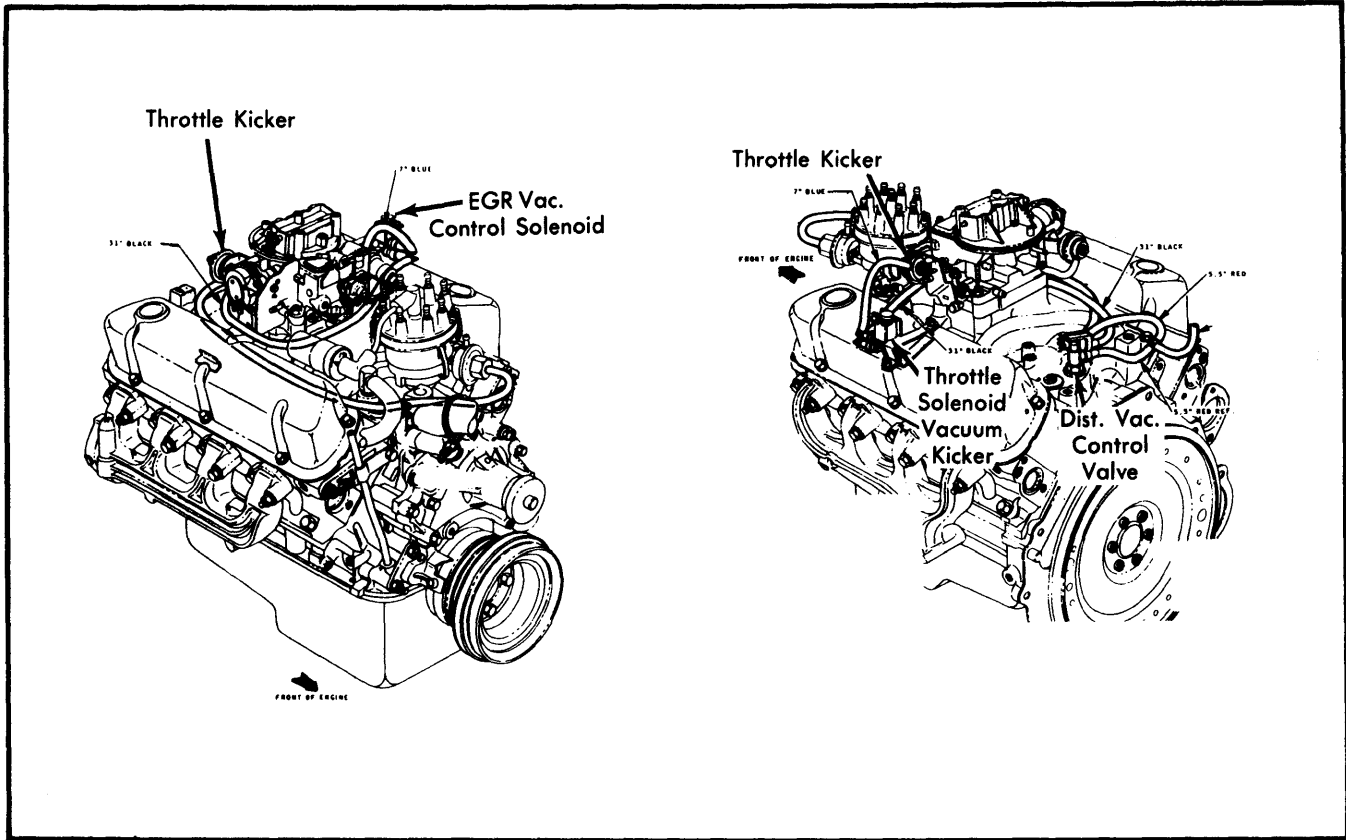

Fig. 11 302" V8 Pickup, Federal with Auto. Trans.

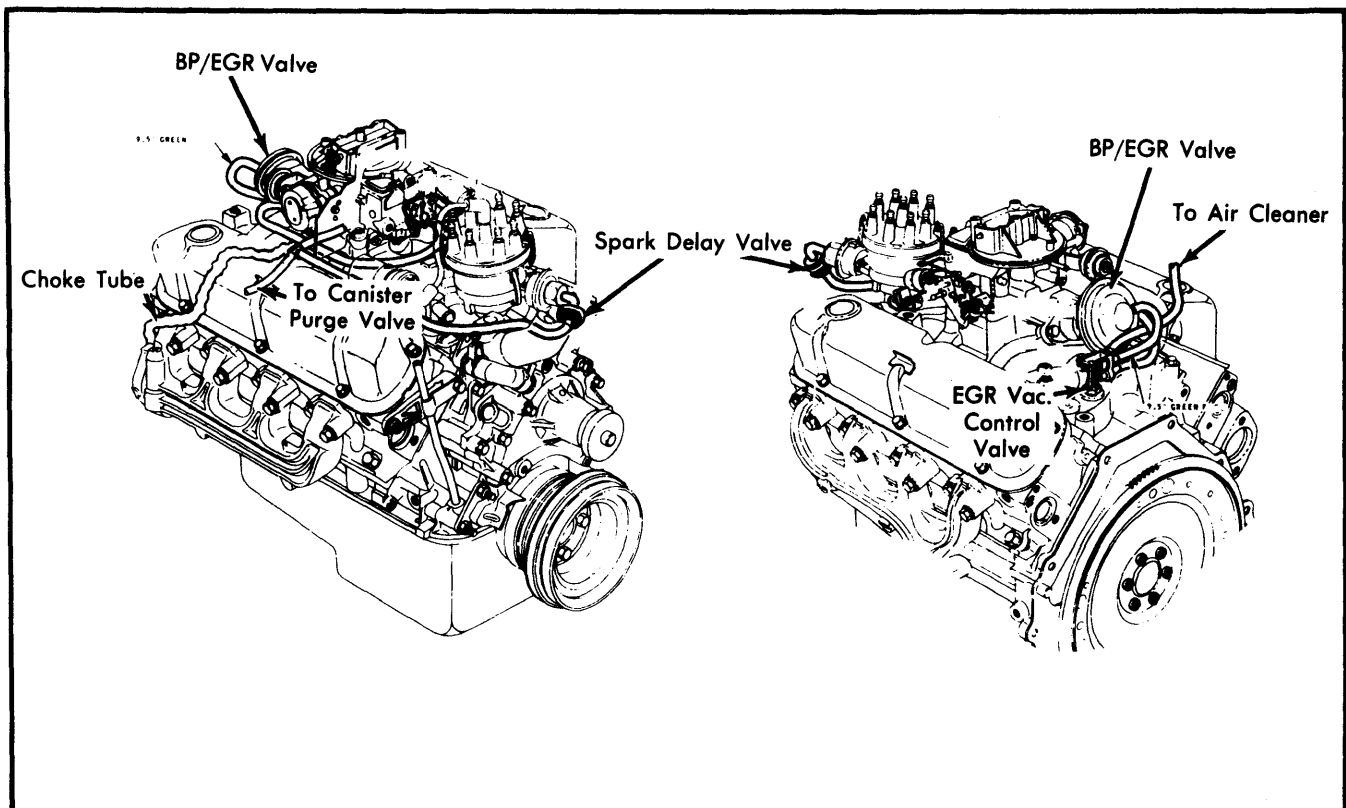

Fig. 12 302" V8 Pickup, Calif. with Auto. Trans.

# 1975-79 EXHAUST EMISSION SYSTEMS

## 1978 Ford Motor Co. Vacuum Diagrams (Cont.)

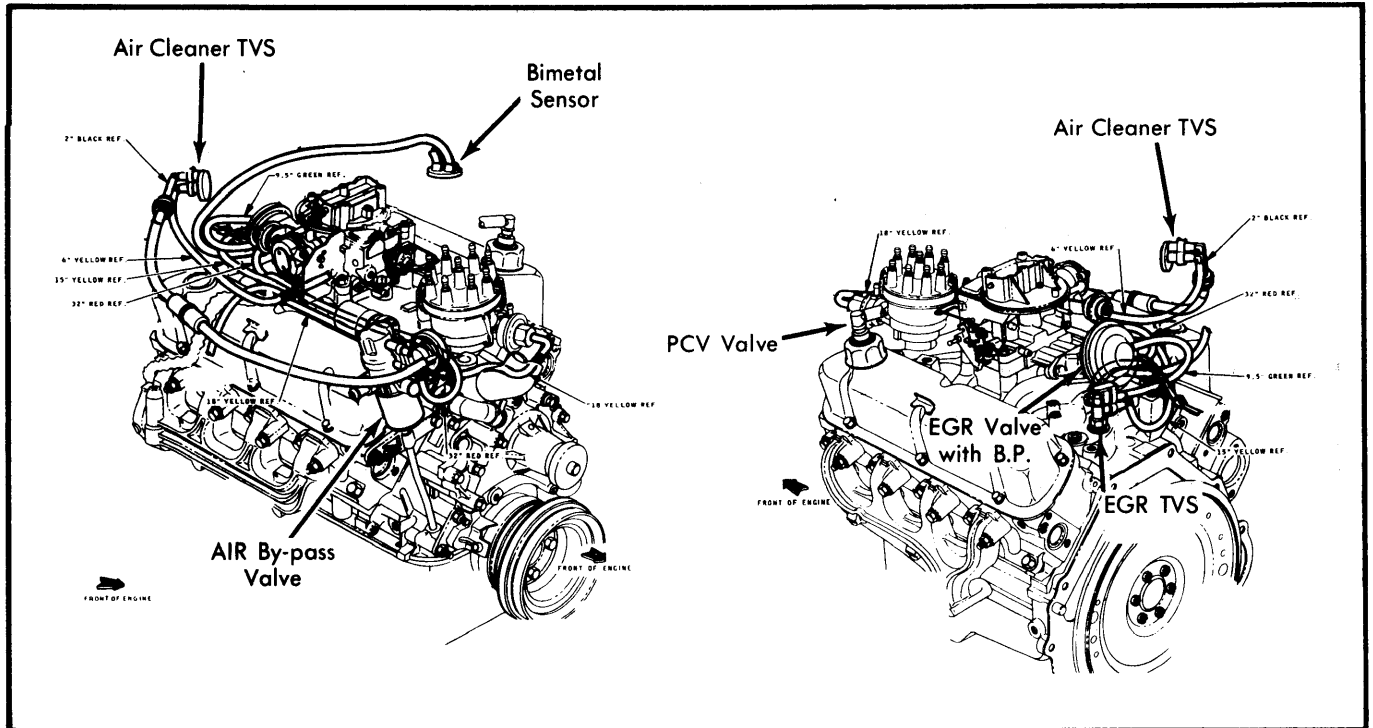

Fig. 13 302" V8 Pickup, Calif. with Man. Trans.

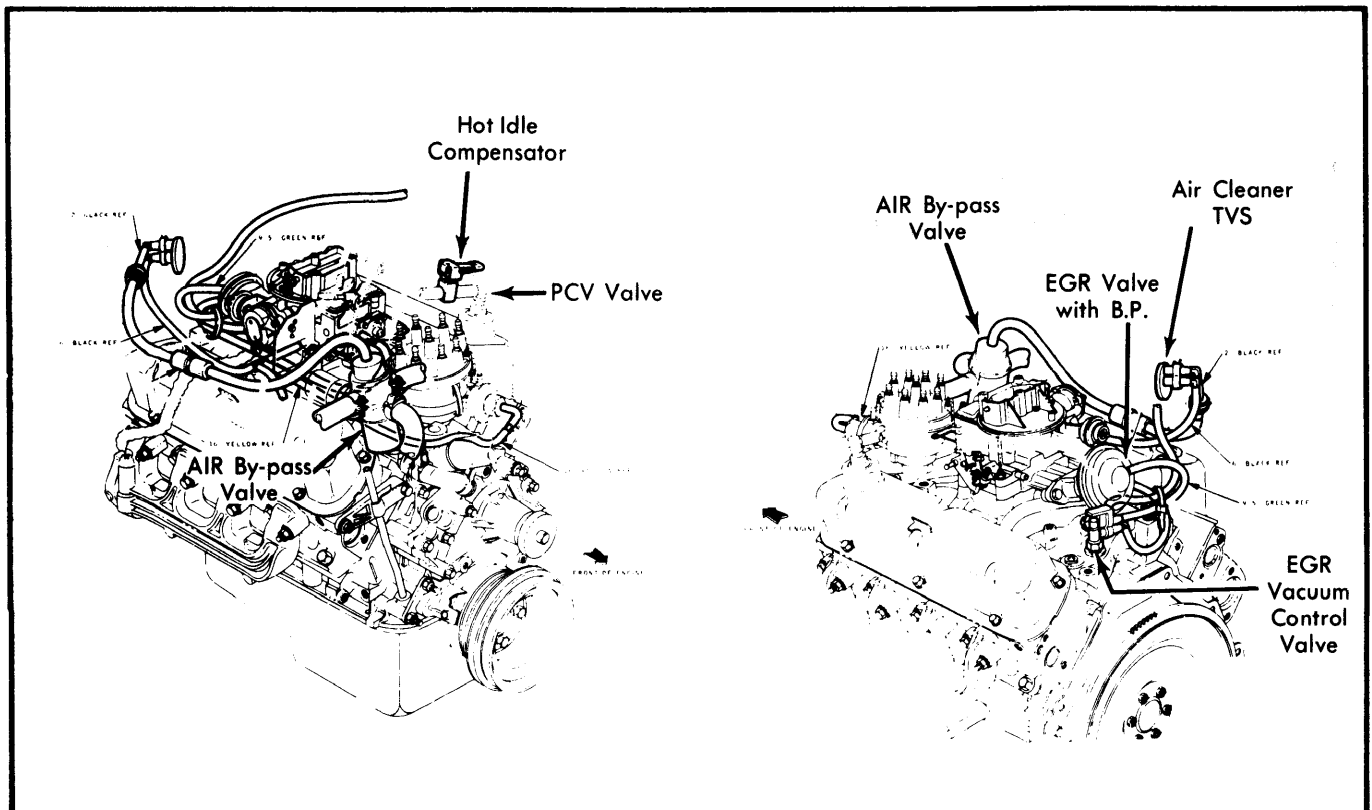

Fig. 14 302" V8 Pickup, Calif. with Auto. Trans.

# 1975-79 EXHAUST EMISSION SYSTEMS

## 1978 Ford Motor Co. Vacuum Diagrams (Cont.)

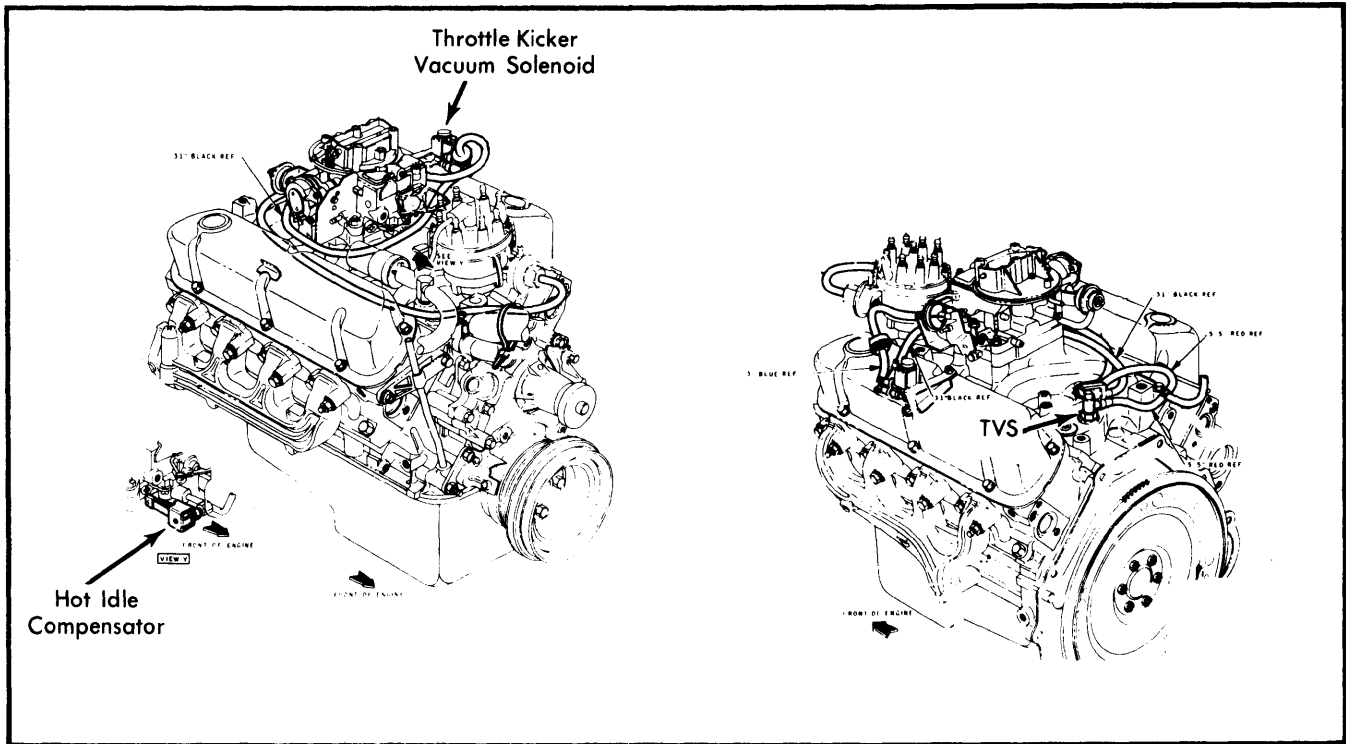

Fig. 15 302" V8 Pickup, Federal with Man. Trans.

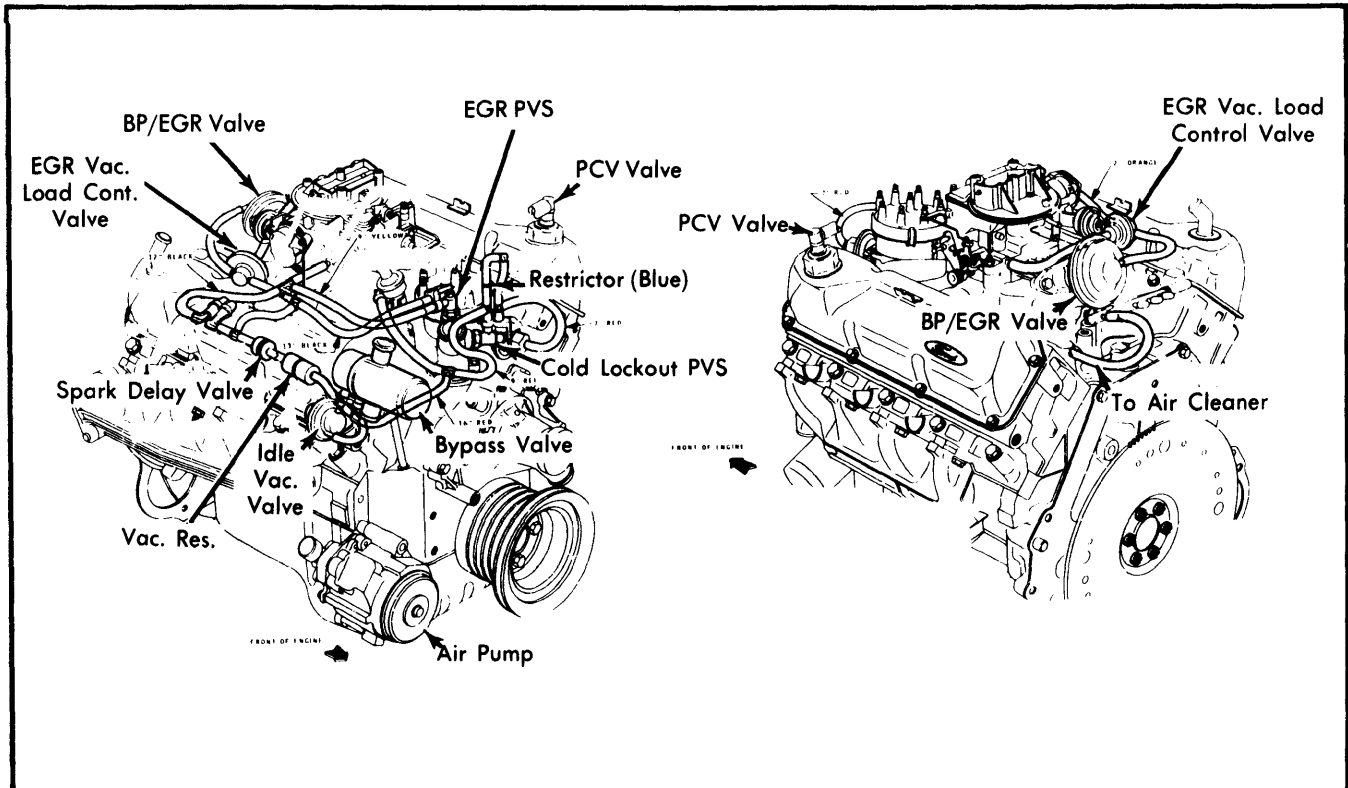
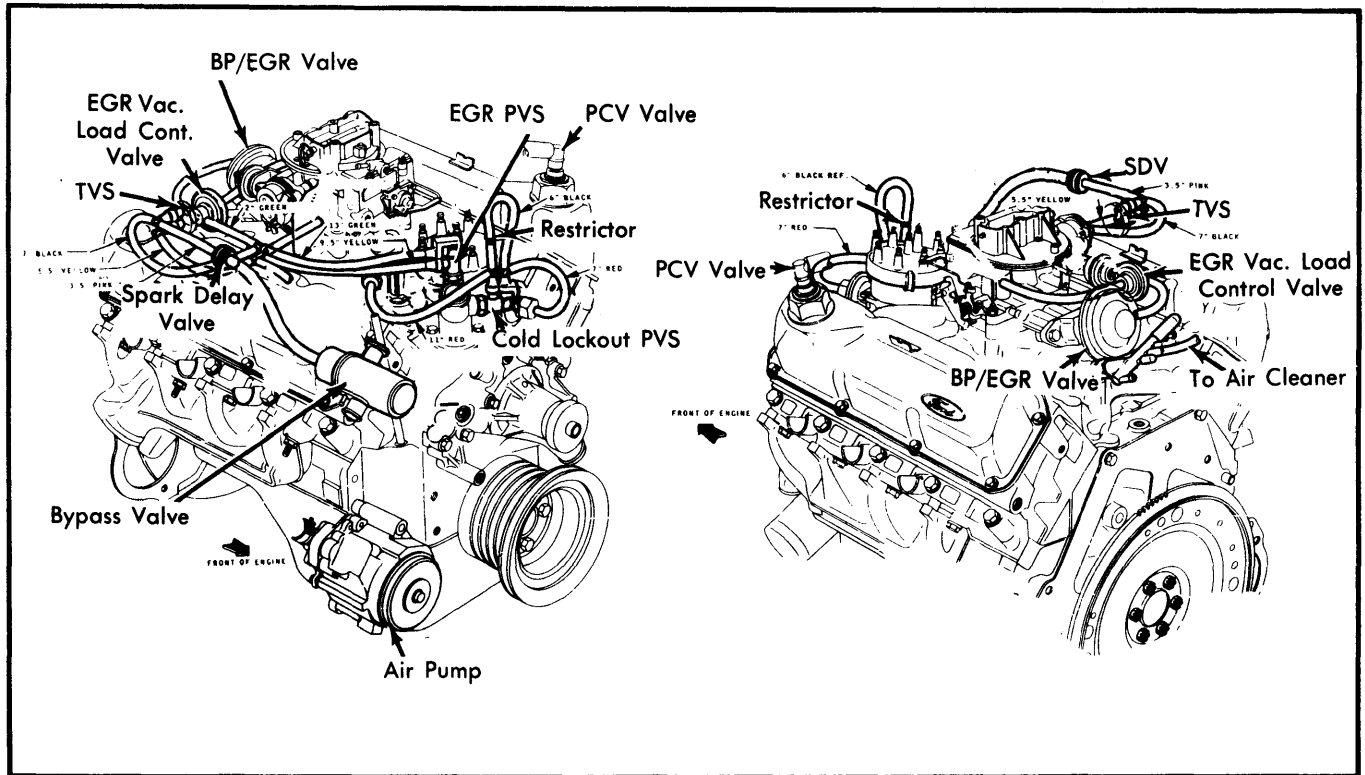

Fig. 16 351" M V8 Pickup, Federal with Man. Trans.

# 1975-79 EXHAUST EMISSION SYSTEMS

## 1978 Ford Motor Co. Vacuum Diagrams (Cont.)



**Fig. 17 351" M V8 Pickup, Federal with Auto. Trans.**

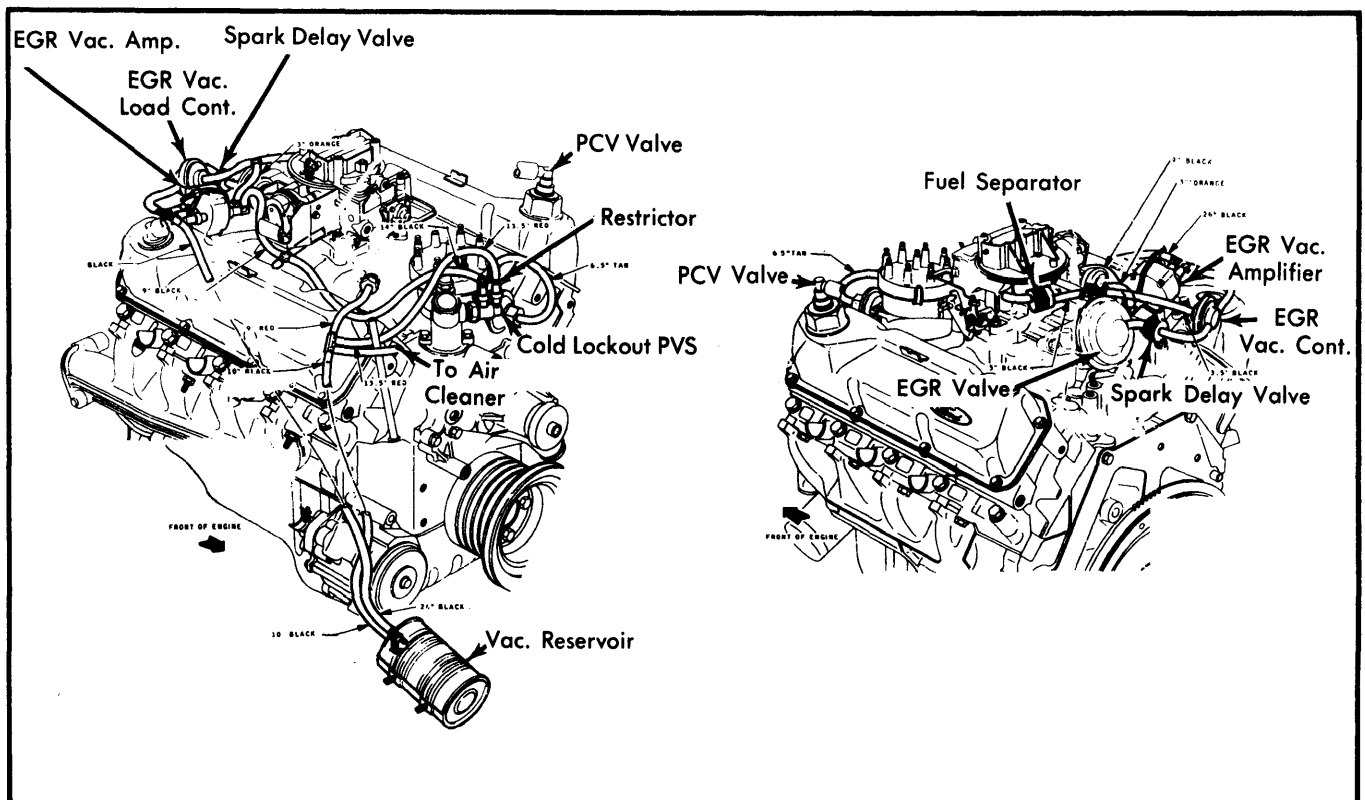

**Fig. 18 351" M V8 Pickup, Federal with Man. Trans.**



# 1975-79 EXHAUST EMISSION SYSTEMS

## 1978 Ford Motor Co. Vacuum Diagrams (Cont.)

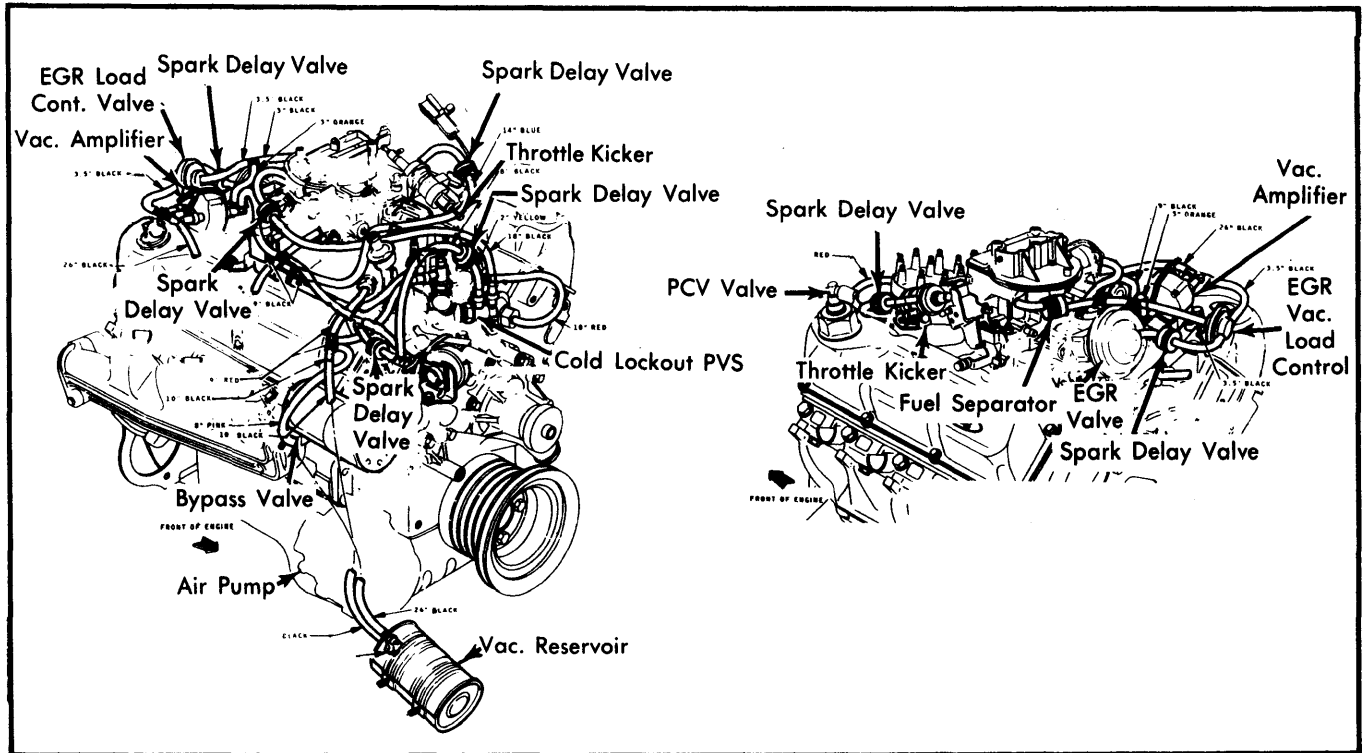

Fig. 21 351M V8 Pickup, Calif. with Auto. Trans.

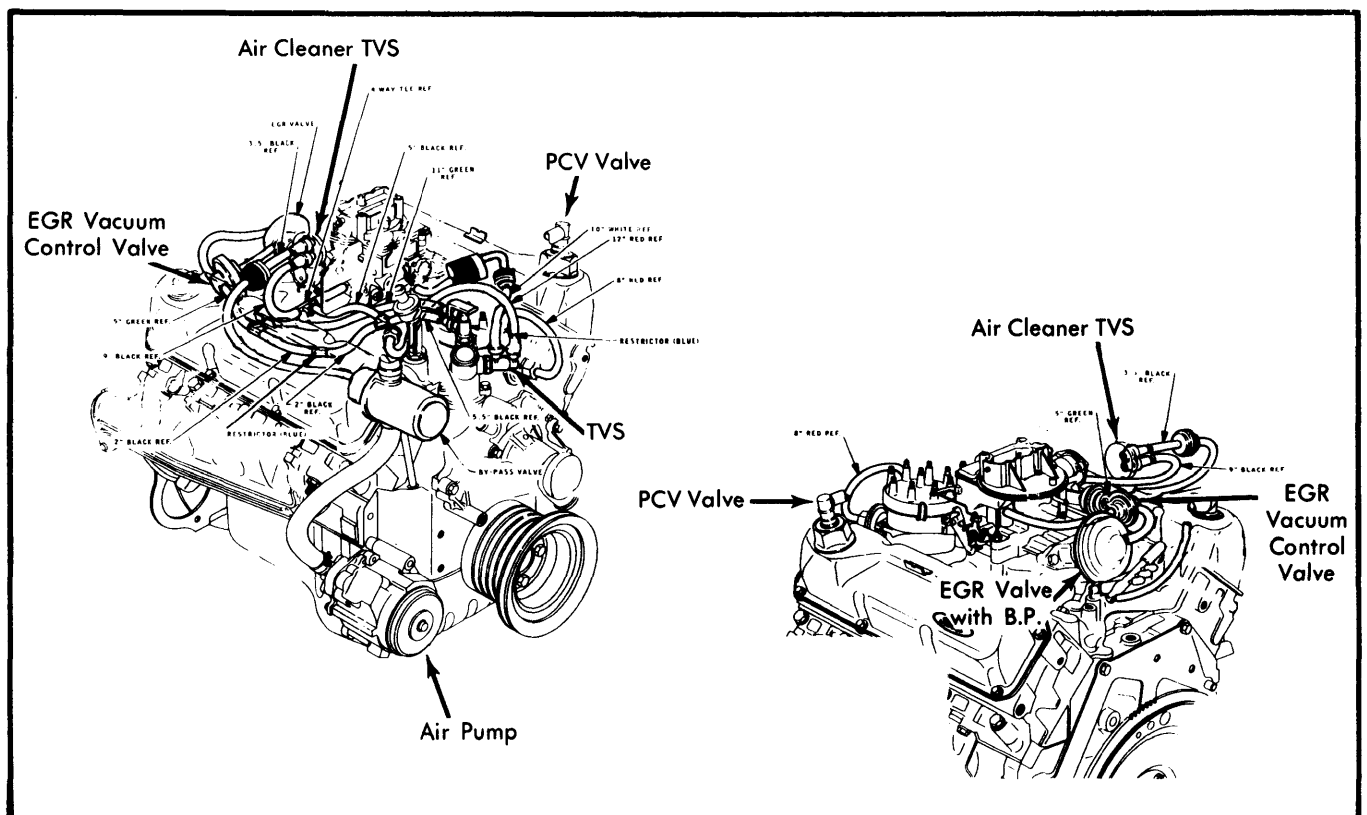

Fig. 22 351M V8 Pickup & Bronco, Calif. with Auto. Trans.

# 1975-79 EXHAUST EMISSION SYSTEMS

## 1978 Ford Motor Co. Vacuum Diagrams (Cont.)

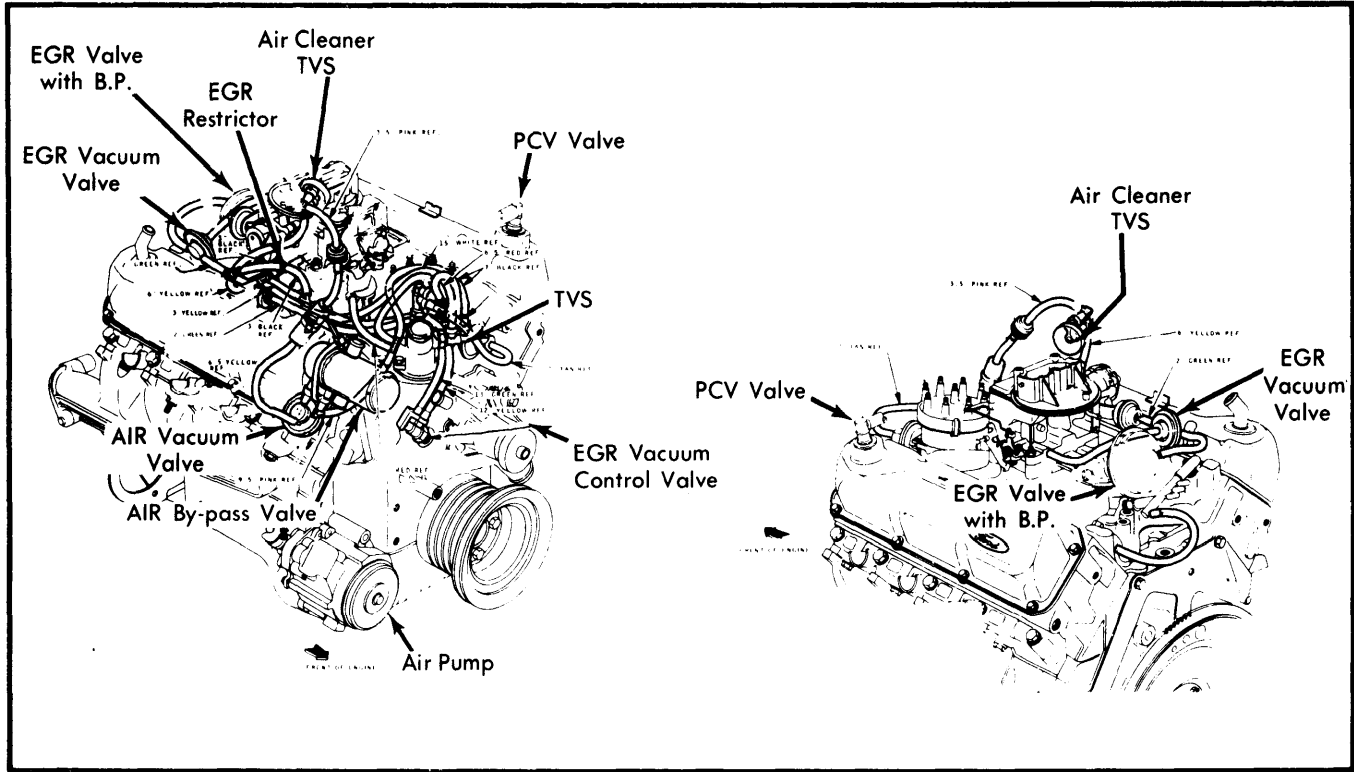

Fig. 23 351" M V8 Pickup & Bronco, Calif. with Man. Trans.

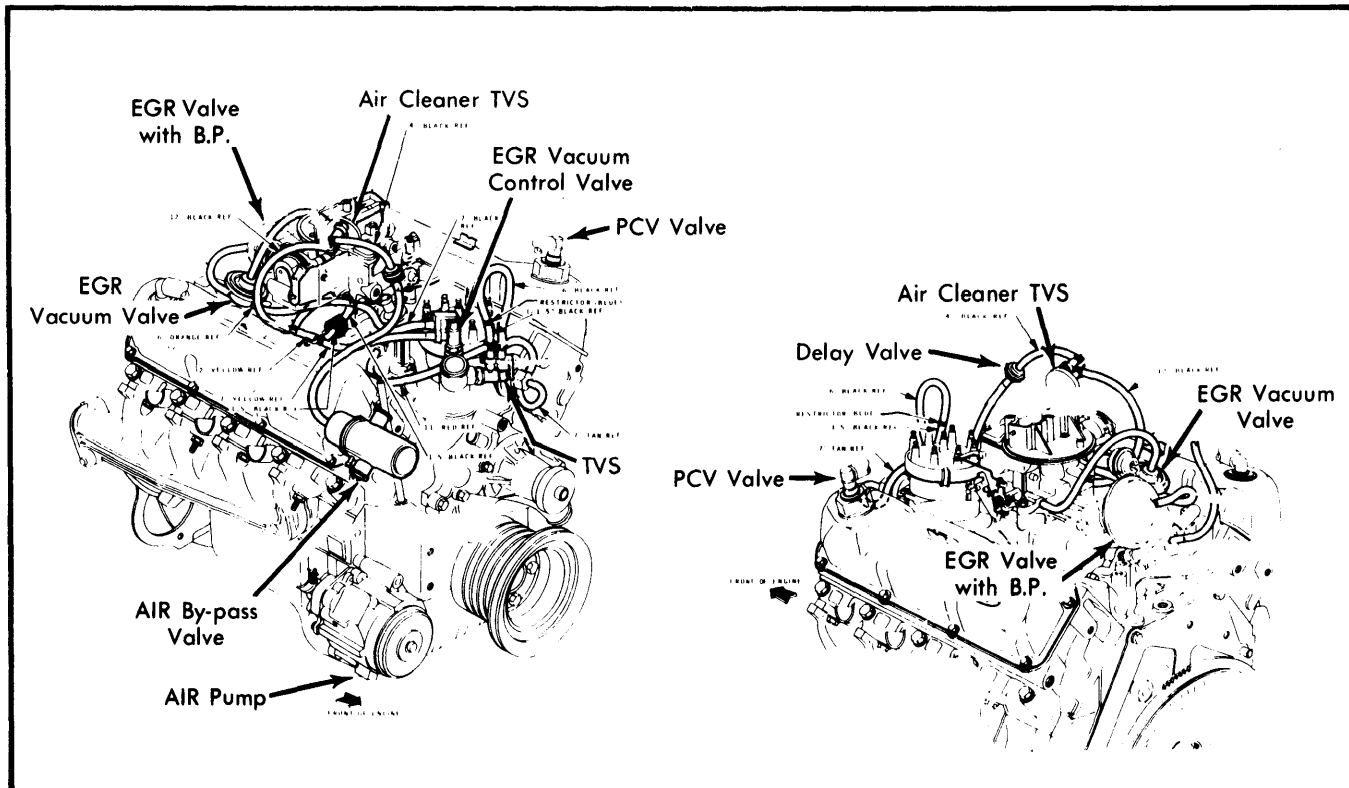

Fig. 24 351" M V8 Pickup & Bronco, Calif. with Auto. Trans.

# 1975-79 EXHAUST EMISSION SYSTEMS

## 1978 Ford Motor Co. Vacuum Diagrams (Cont.)

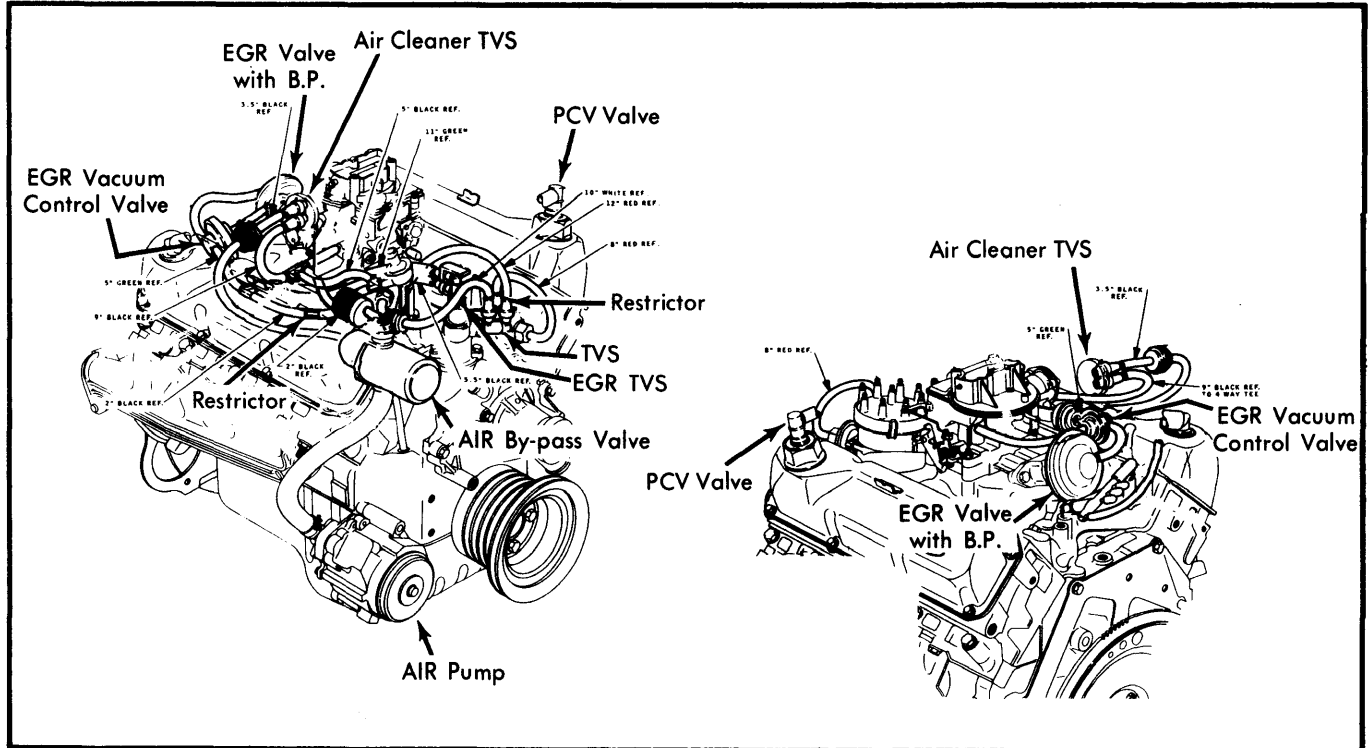

Fig. 25 351\"/>

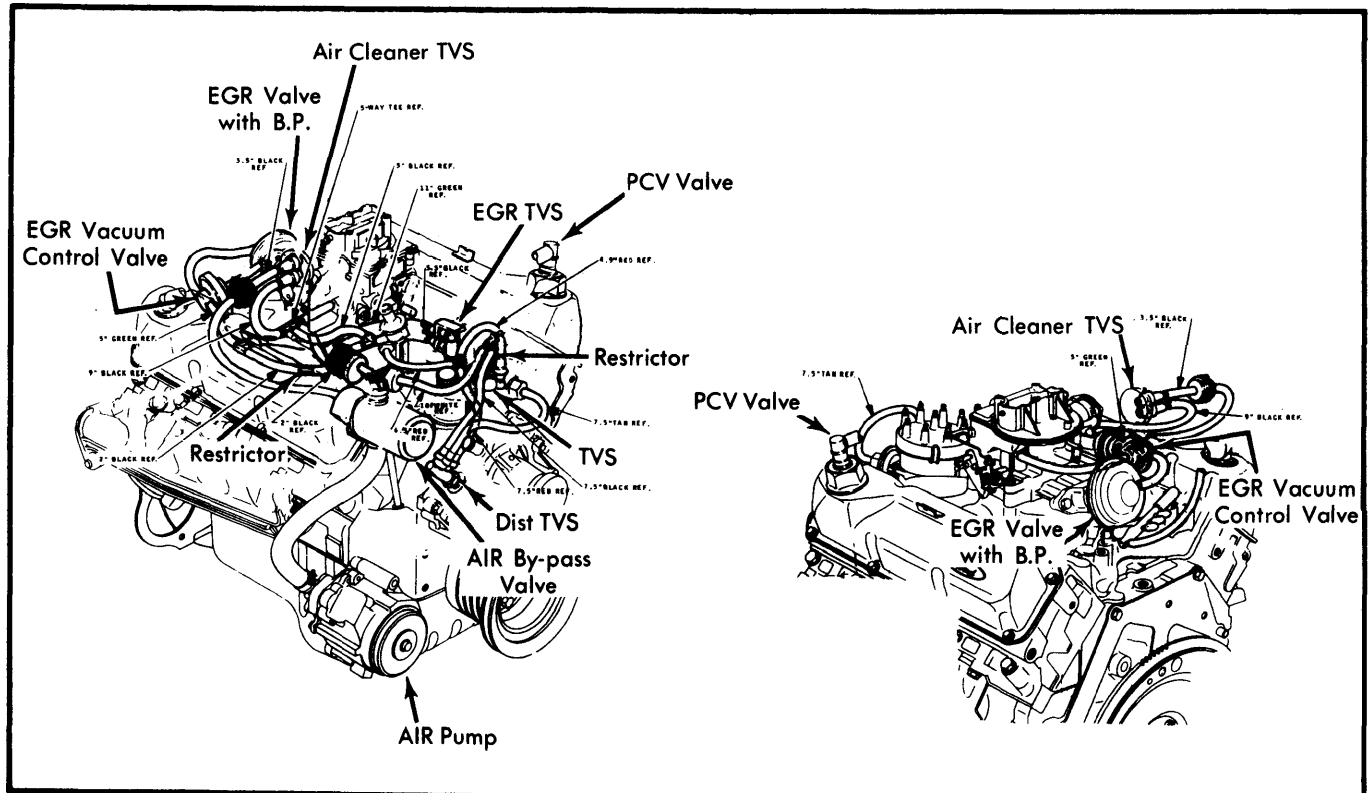

Fig. 26 351\"/>

# 1975-79 EXHAUST EMISSION SYSTEMS

## 1978 Ford Motor Co. Vacuum Diagrams (Cont.)

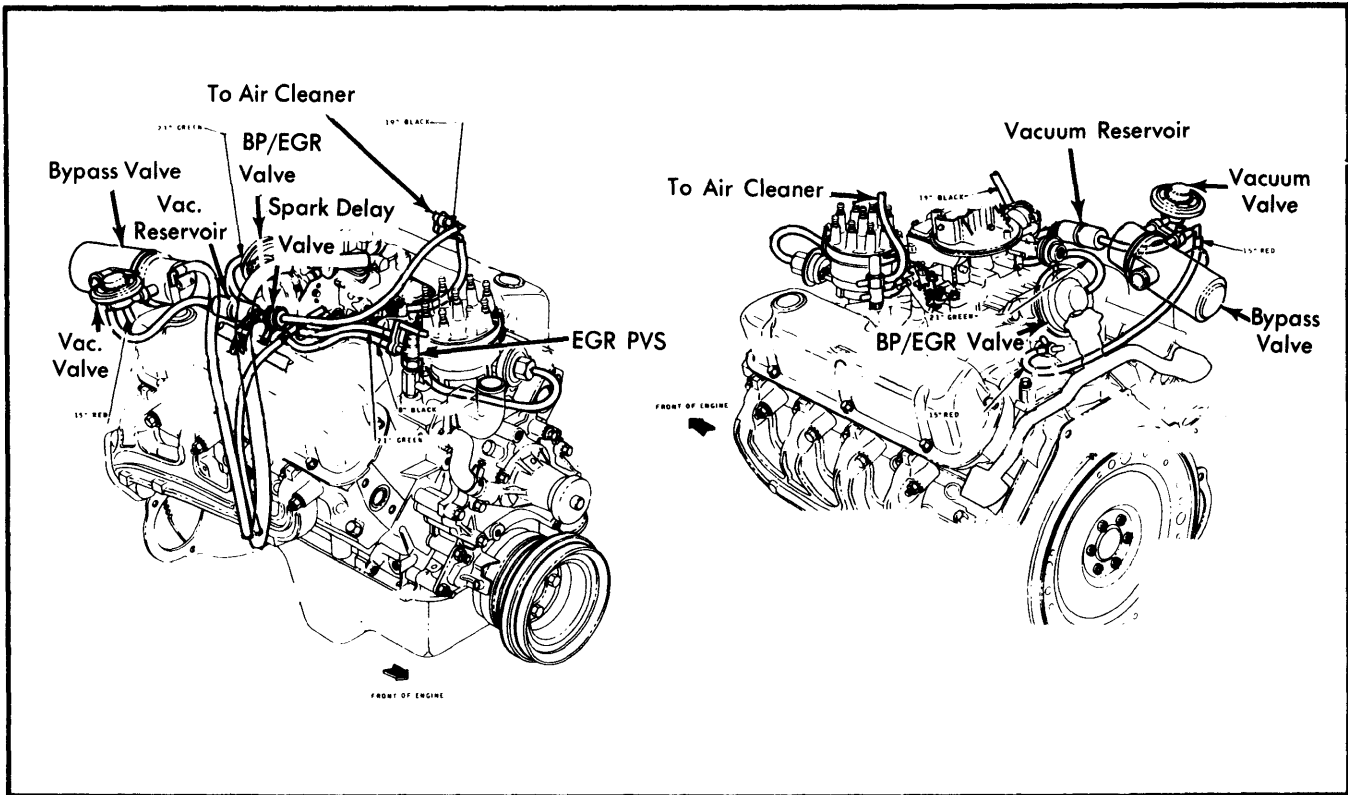

Fig. 27 351" W V8 Van, Federal with Man. Trans.

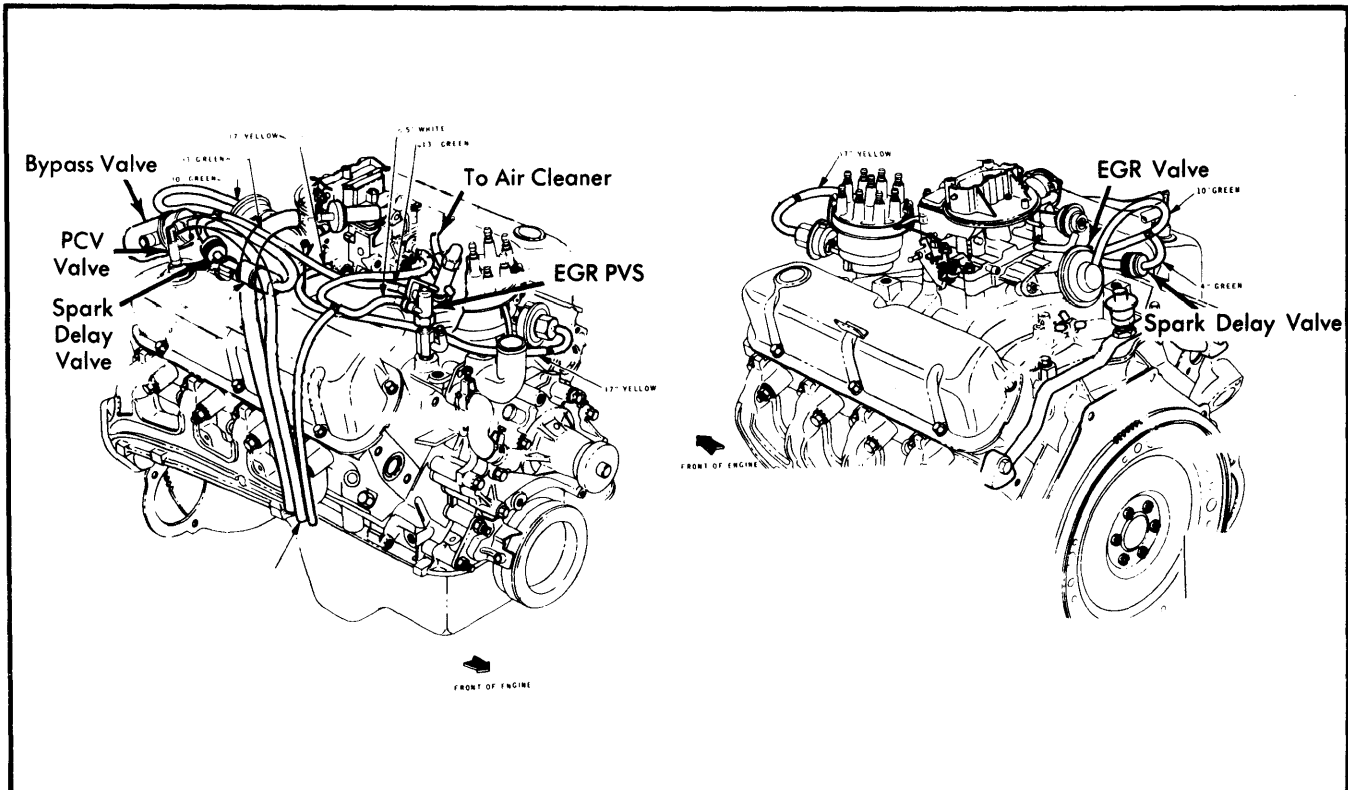

Fig. 28 351" W V8 Van, Federal with Auto. Trans.

# 1975-79 EXHAUST EMISSION SYSTEMS

## 1978 Ford Motor Co. Vacuum Diagrams (Cont.)

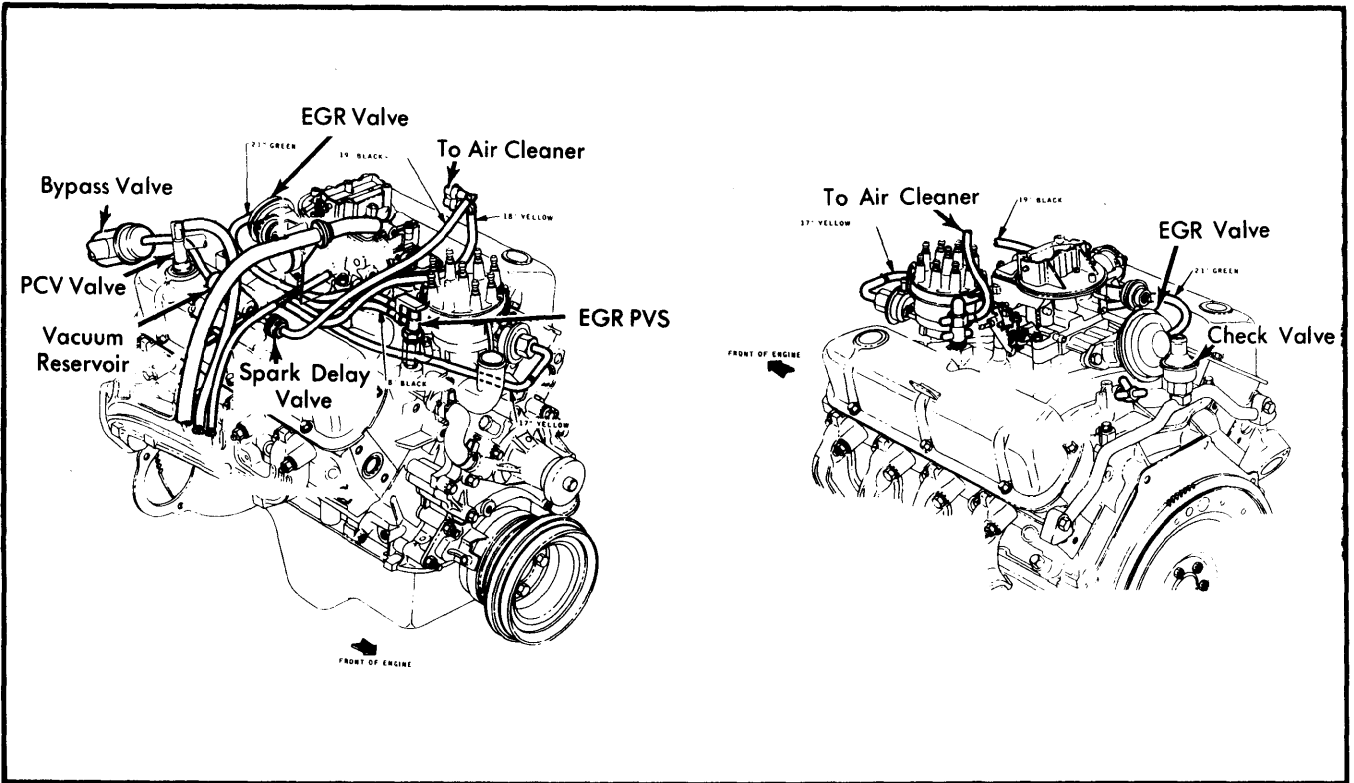

Fig. 29 351"W V8 Van, Calif. with Auto. Trans.

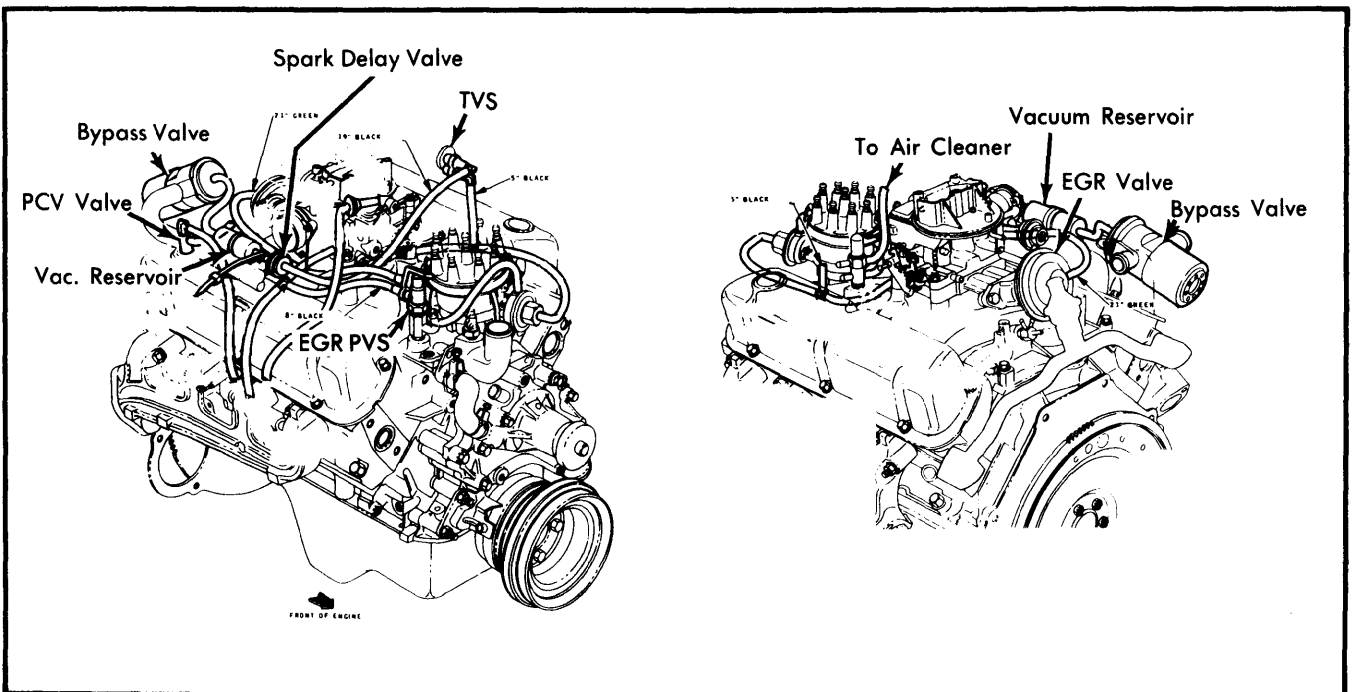

Fig. 30 351"W V8 Van, Calif. with Man. Trans.

# 1975-79 EXHAUST EMISSION SYSTEMS

## 1978 Ford Motor Co. Vacuum Diagrams (Cont.)

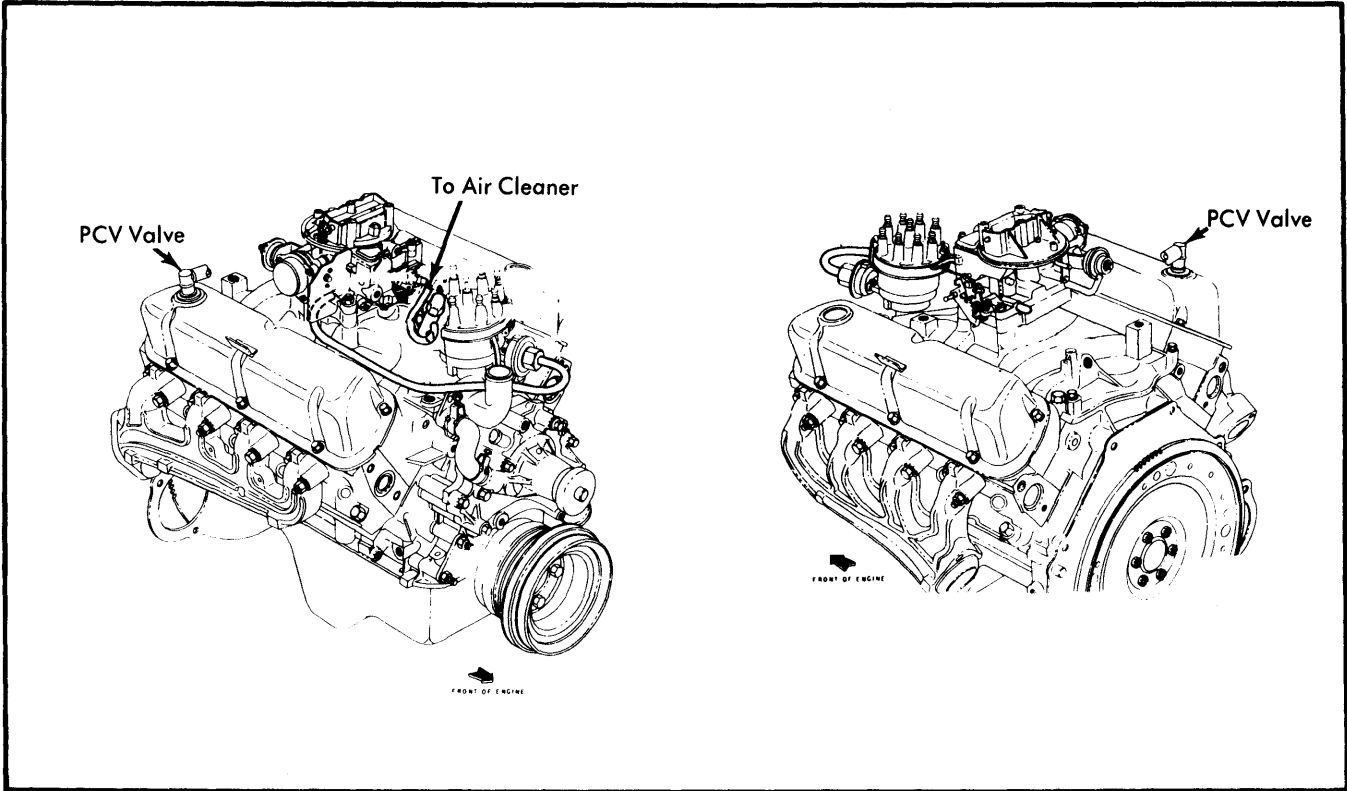

Fig. 31 351" W V8 Van, Federal with Man. Trans.

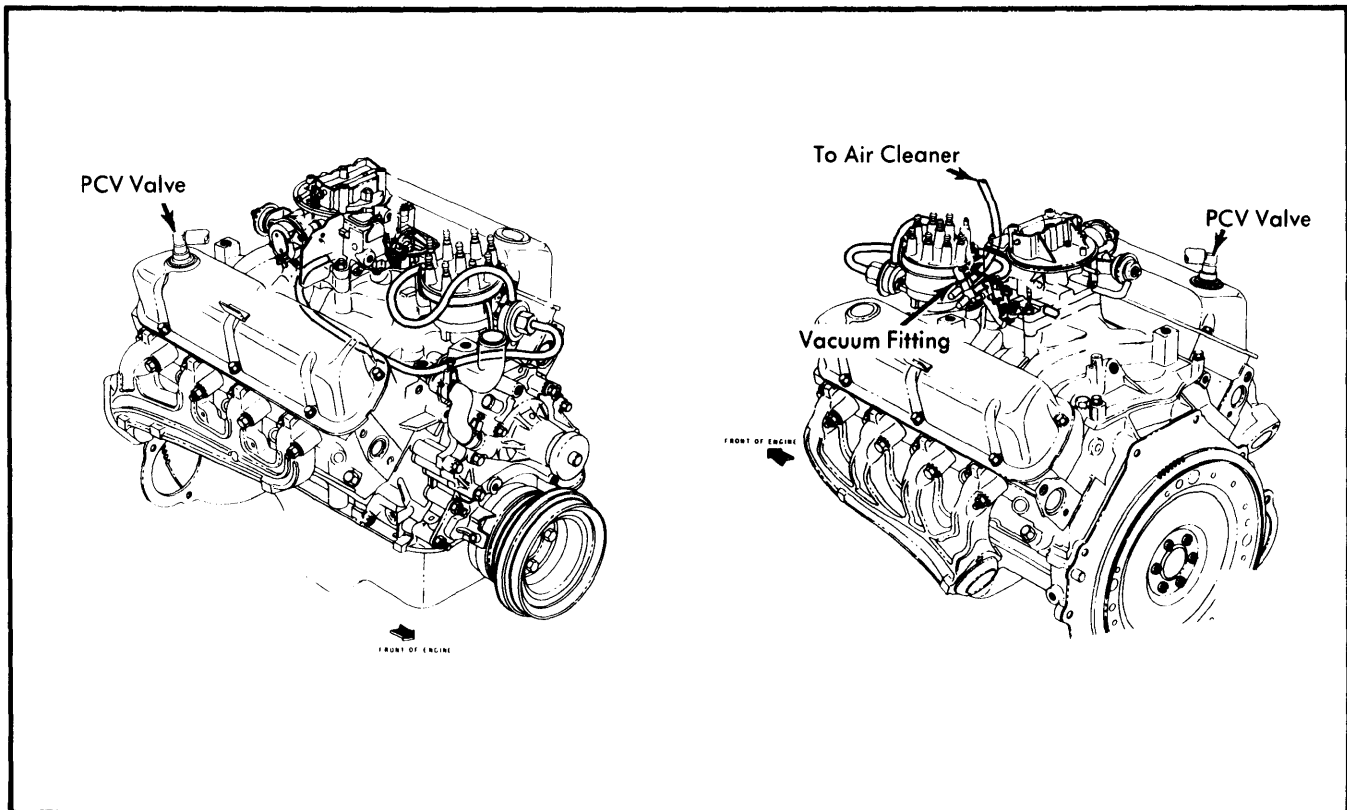
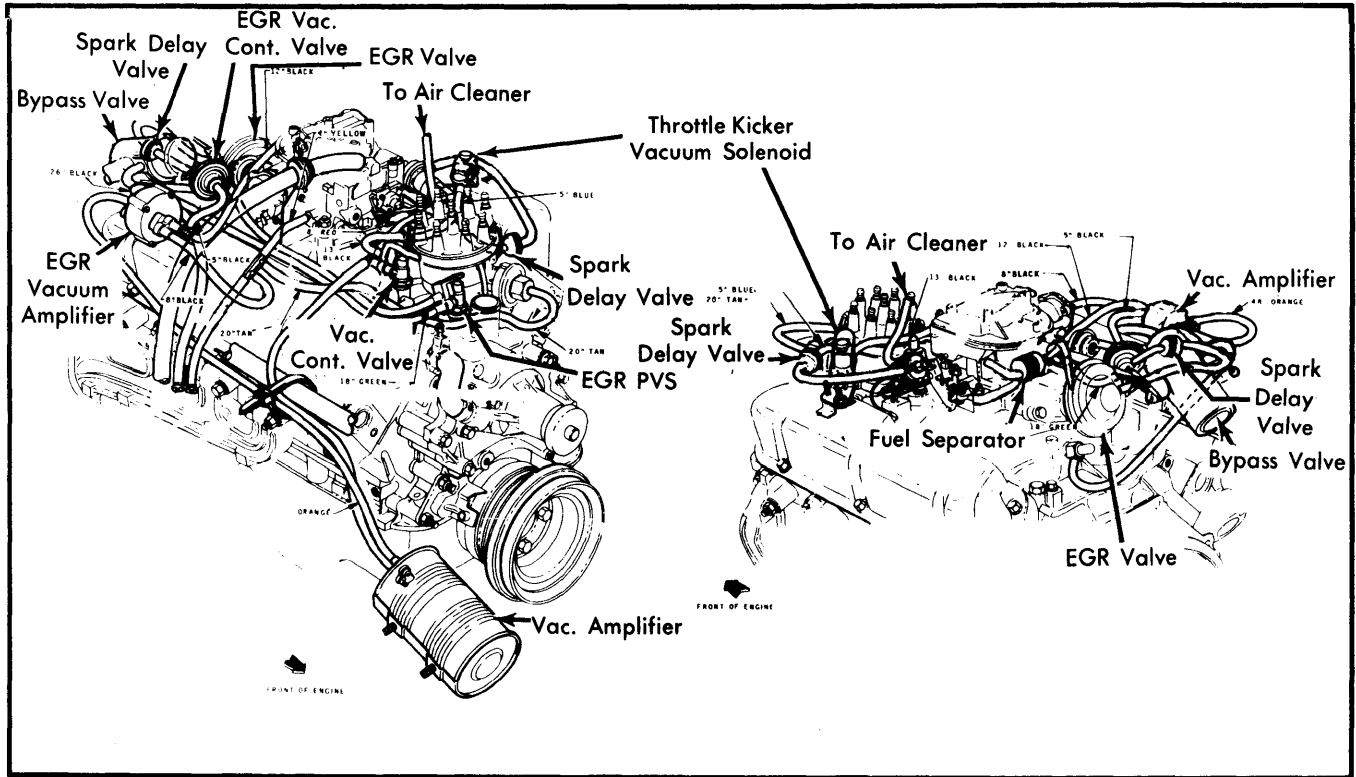

Fig. 32 351" W V8 Van, Federal with Auto. Trans.

# 1975-79 EXHAUST EMISSION SYSTEMS

## 1978 Ford Motor Co. Vacuum Diagrams (Cont.)



**Fig. 33 351"W V8 Van, Calif. with Auto. Trans.**

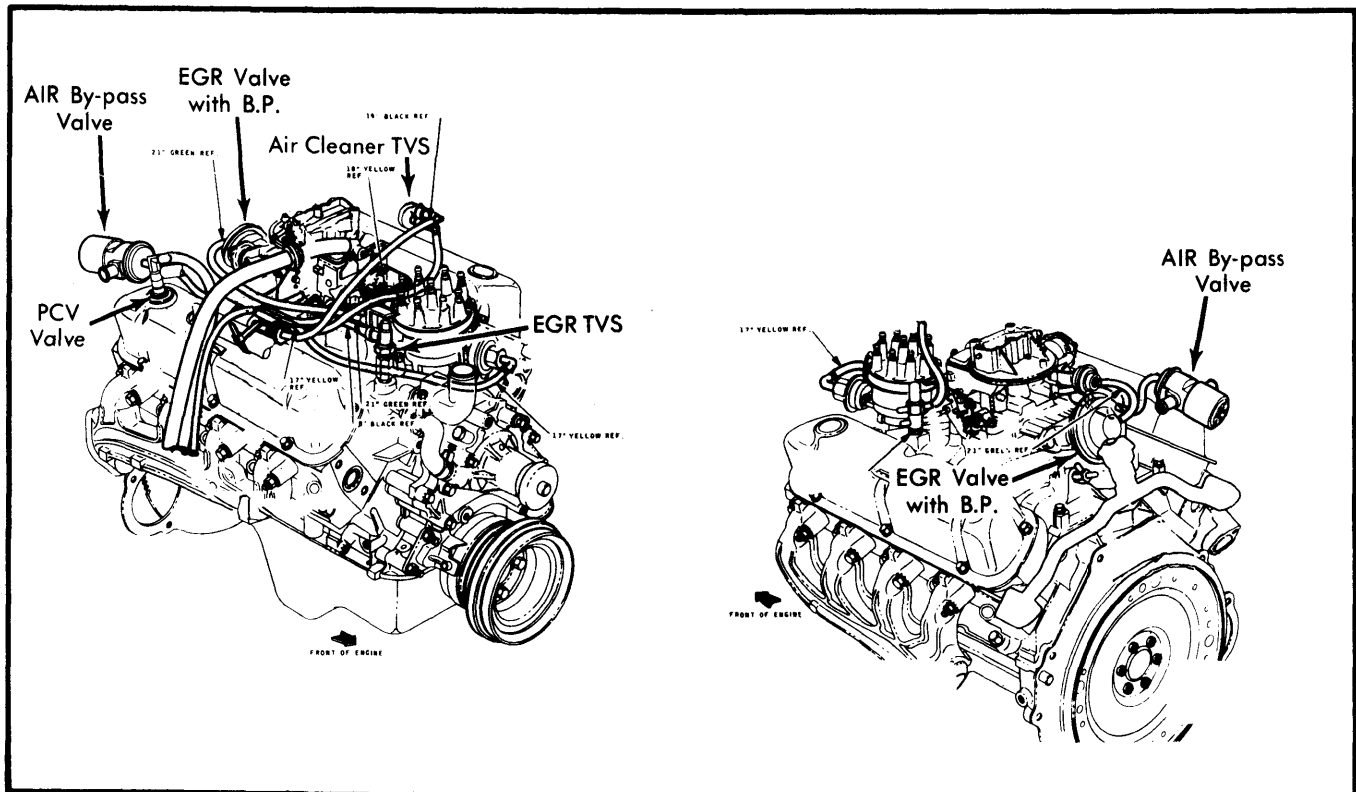

**Fig. 34 351"W V8 Van, Calif. with Auto. Trans.**

# 1975-79 EXHAUST EMISSION SYSTEMS

## 1978 Ford Motor Co. Vacuum Diagrams (Cont.)

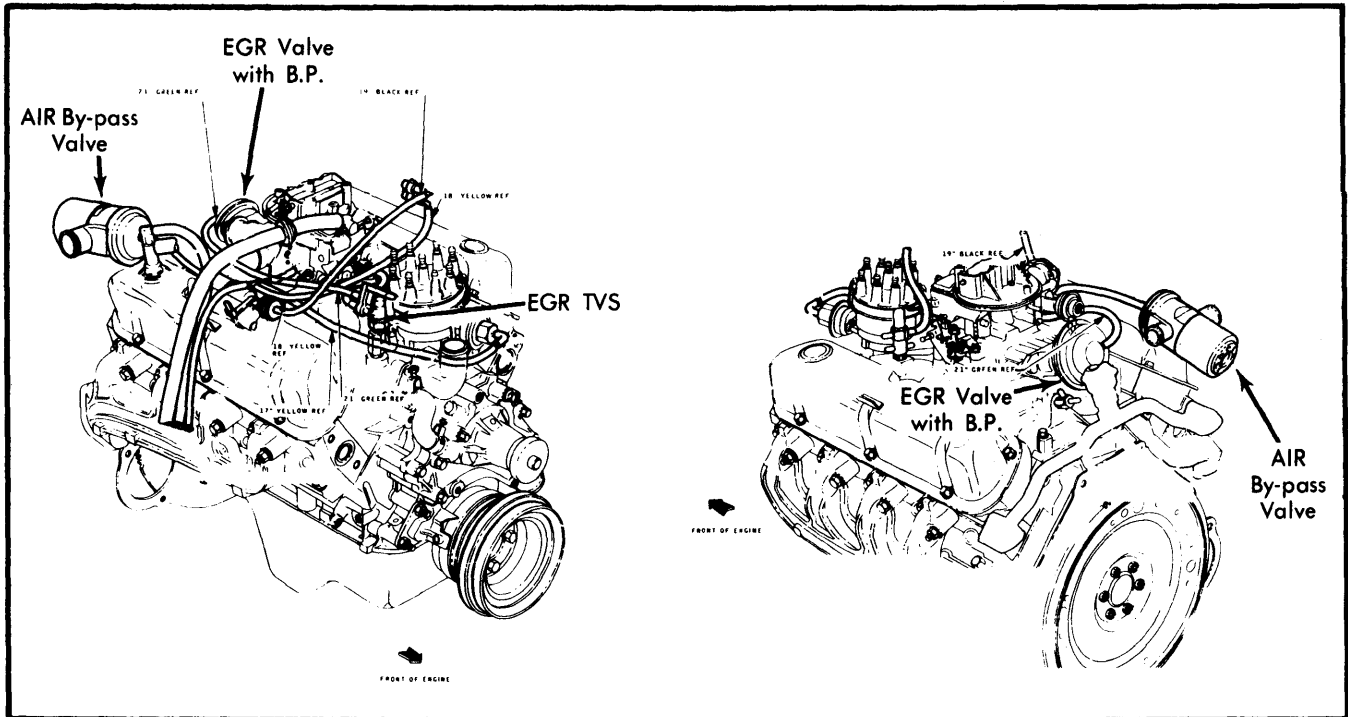

Fig. 35 351" W V8 Van, Federal with Auto. Trans.

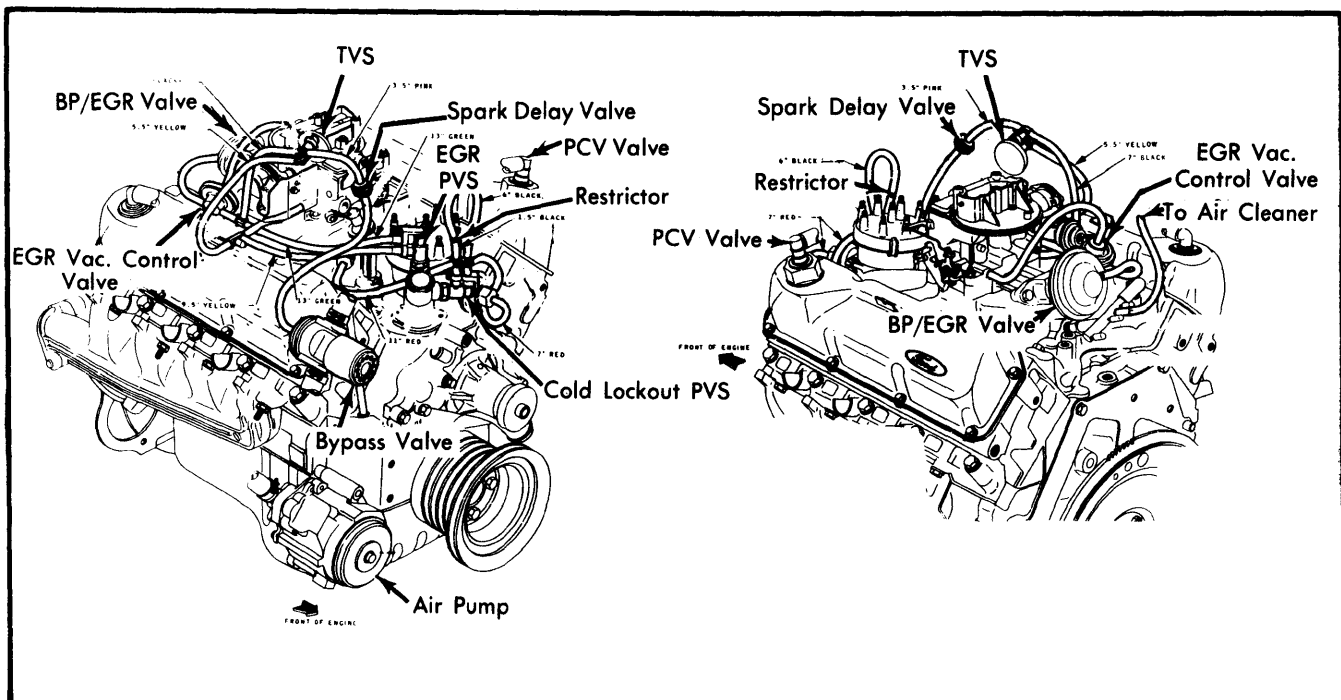
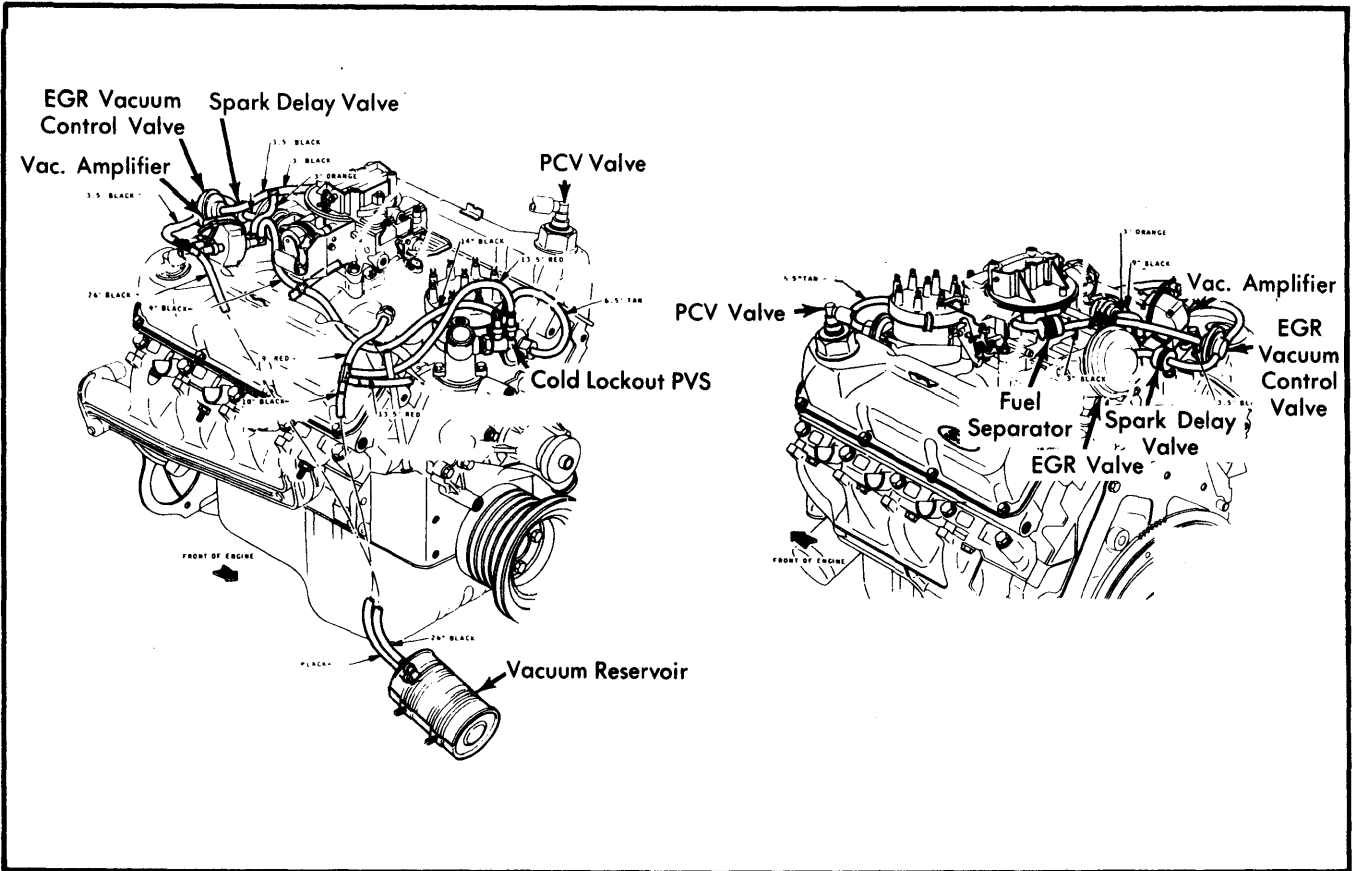

Fig. 36 400" V8 Pickup, Federal with Auto. Trans.

# 1975-79 EXHAUST EMISSION SYSTEMS

## 1978 Ford Motor Co. Vacuum Diagrams (Cont.)



**Fig. 37** 400" V8 Pickup, Federal with Auto. Trans.

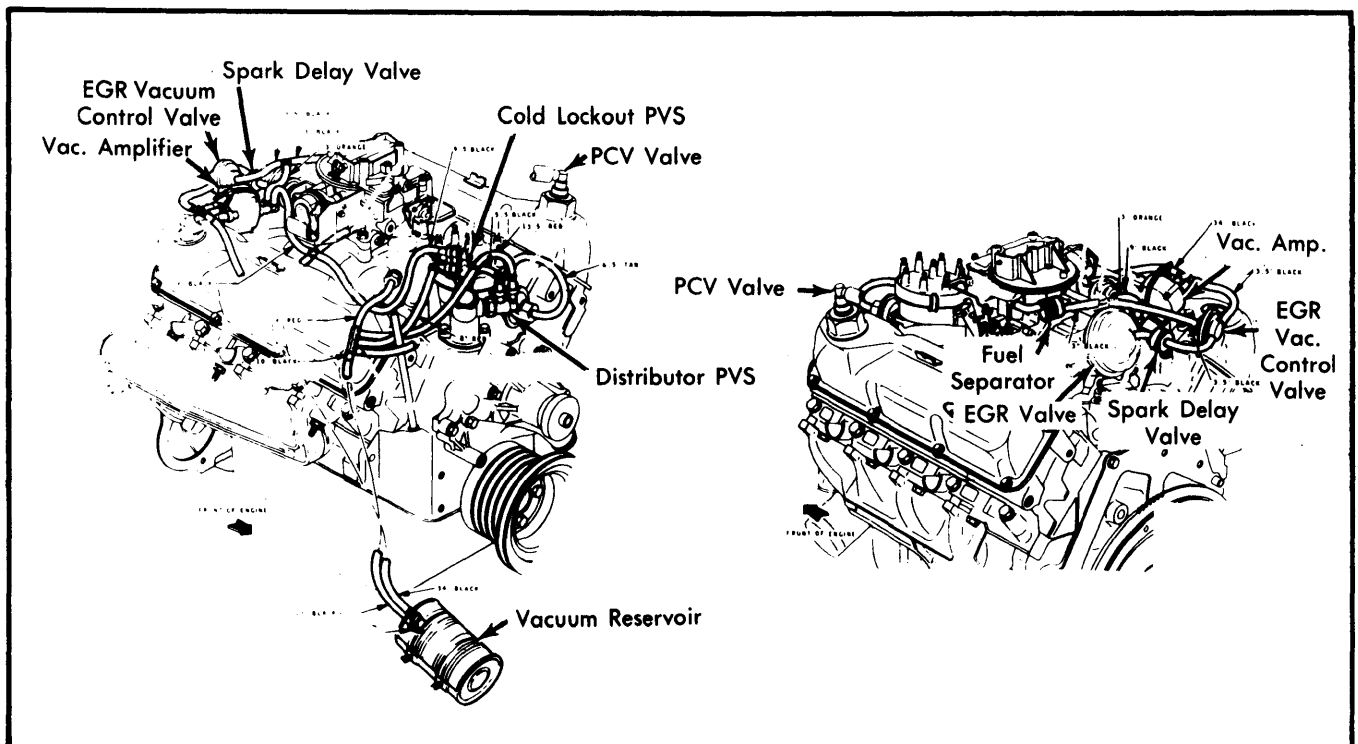

**Fig. 38** 400" V8 Pickup, Federal with Auto. Trans.

# 1975-79 EXHAUST EMISSION SYSTEMS

## 1978 Ford Motor Co. Vacuum Diagrams (Cont.)

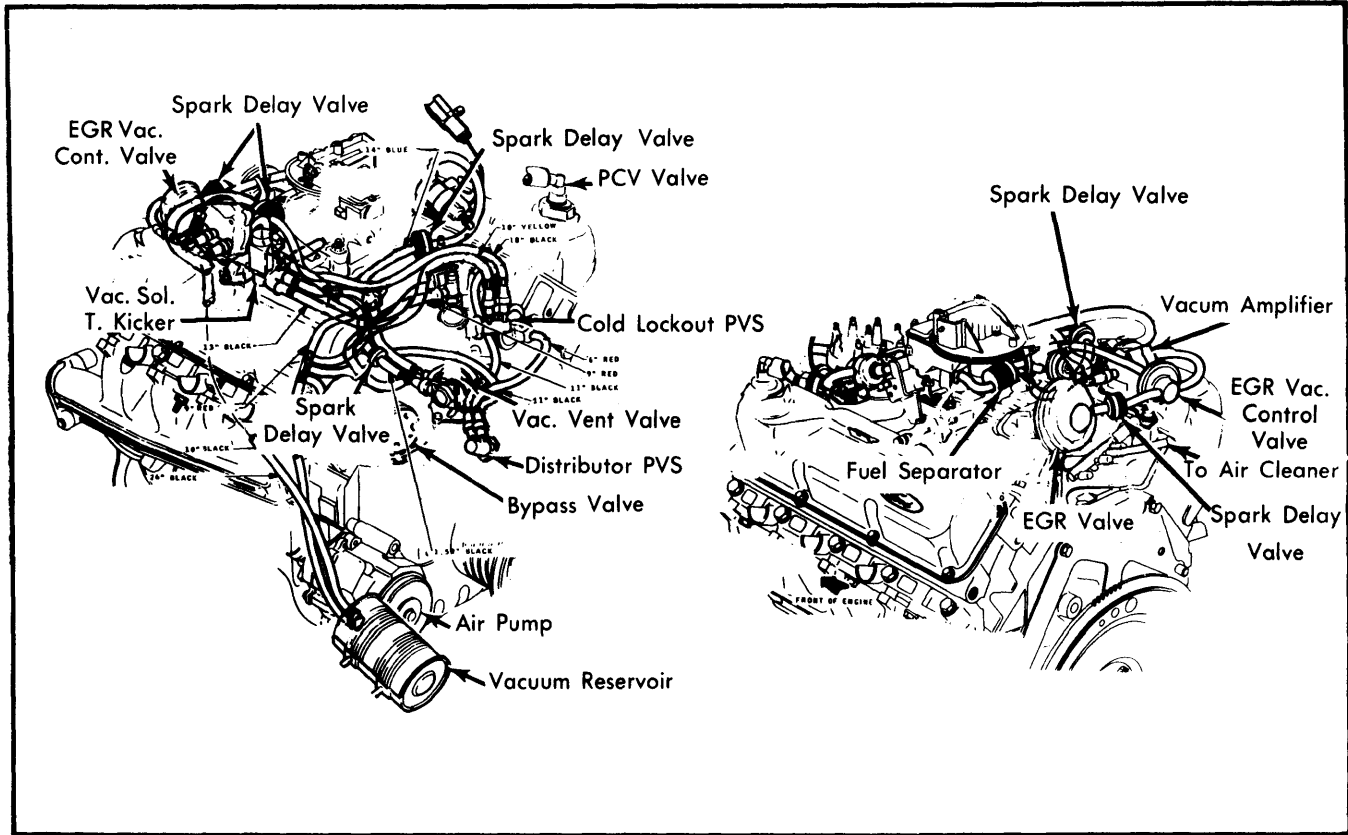

Fig. 39 400" V8 Pickup, Calif. with Auto. Trans.

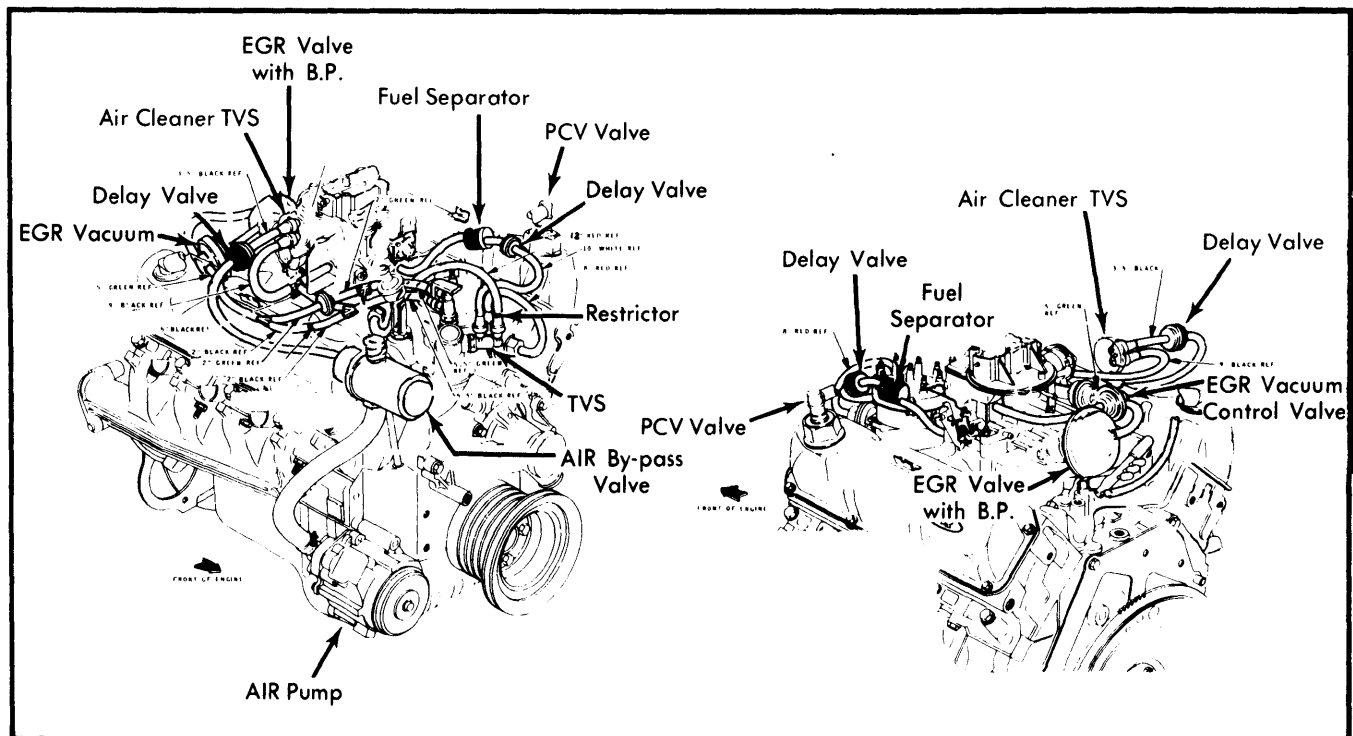

Fig. 40 400" V8 Pickup & Bronco, Calif. with Auto. Trans.

# 1975-79 EXHAUST EMISSION SYSTEMS

## 1978 Ford Motor Co. Vacuum Diagrams (Cont.)

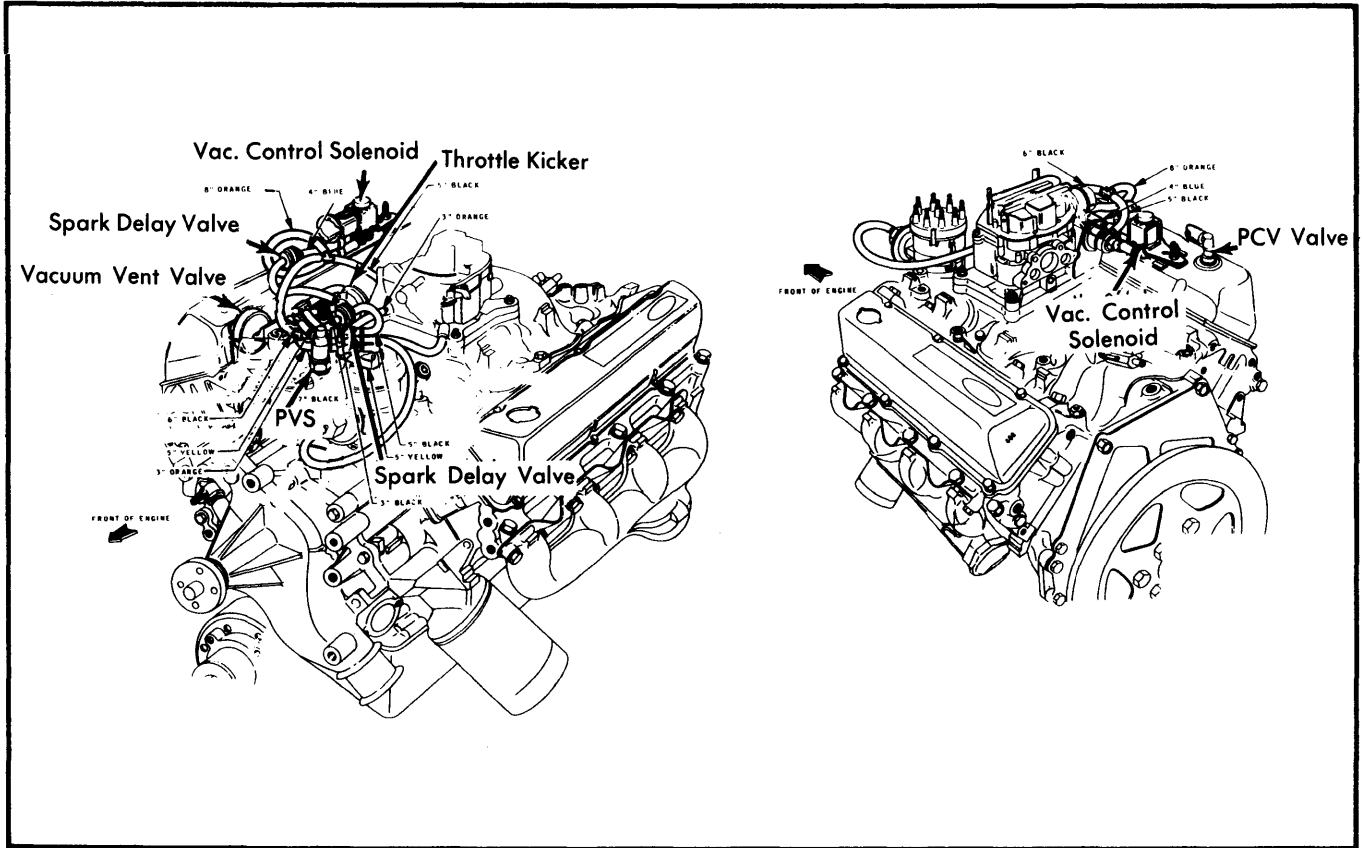

Fig. 41 460" V8 Pickup, Federal with Auto. Trans. (W/O AC)

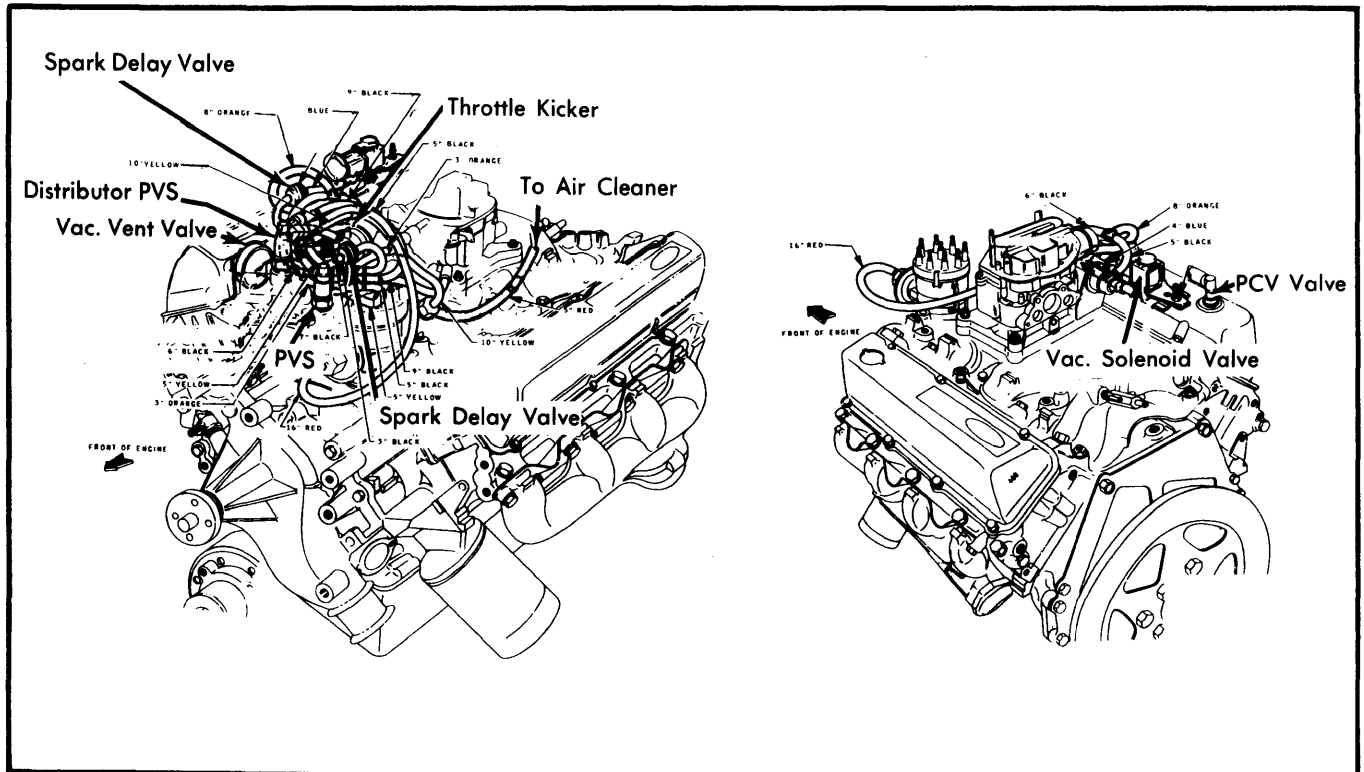

Fig. 42 460" V8 Pickup & Van, Federal with Auto. Trans. (W/AC)

# 1975-79 EXHAUST EMISSION SYSTEMS

## 1978 Ford Motor Co. Vacuum Diagrams (Cont.)

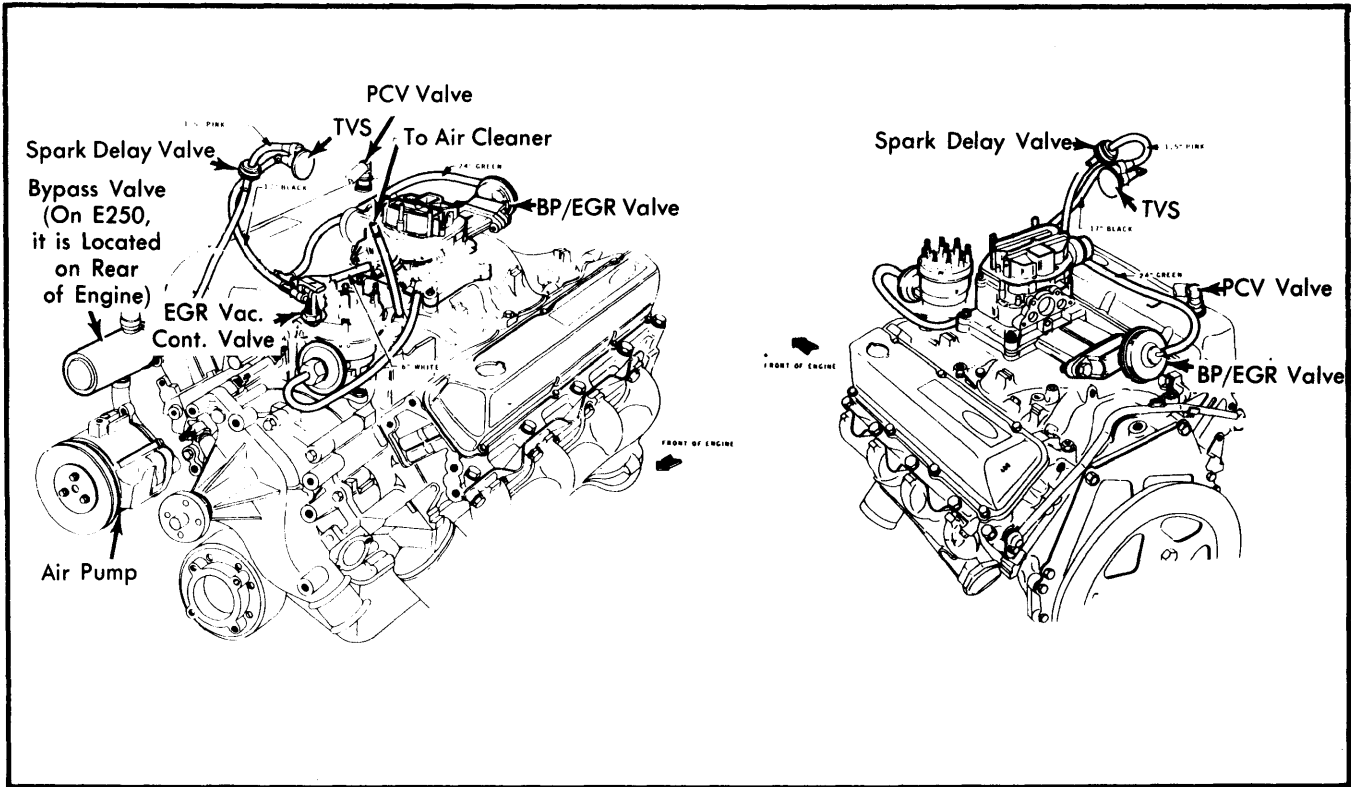

Fig. 43 460" V8 Pickup & Van, Calif. with Auto. Trans.

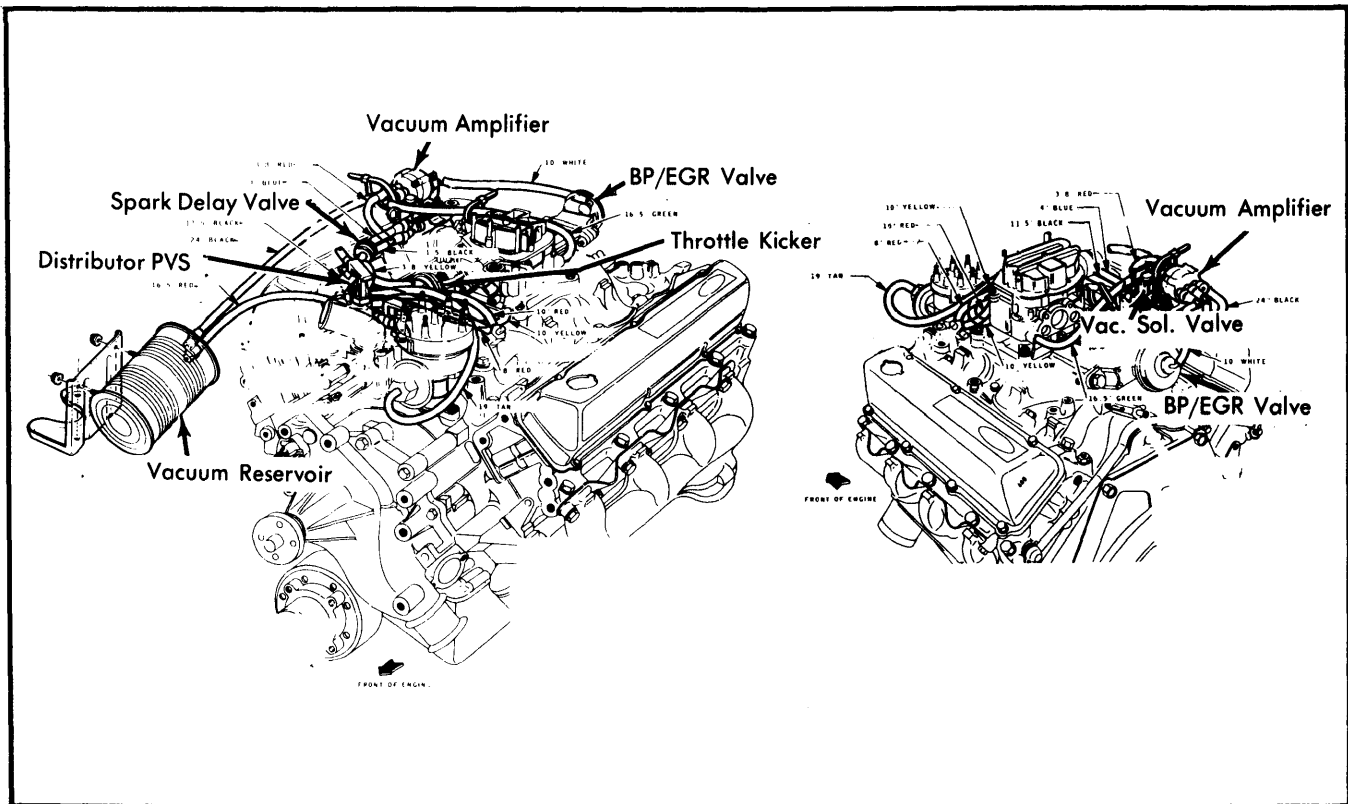

Fig. 44 460" V8 Pickup, Calif. with Auto. Trans.