

1975-79 EXHAUST EMISSION SYSTEMS 1978 Chrysler Corp. Vacuum Diagrams

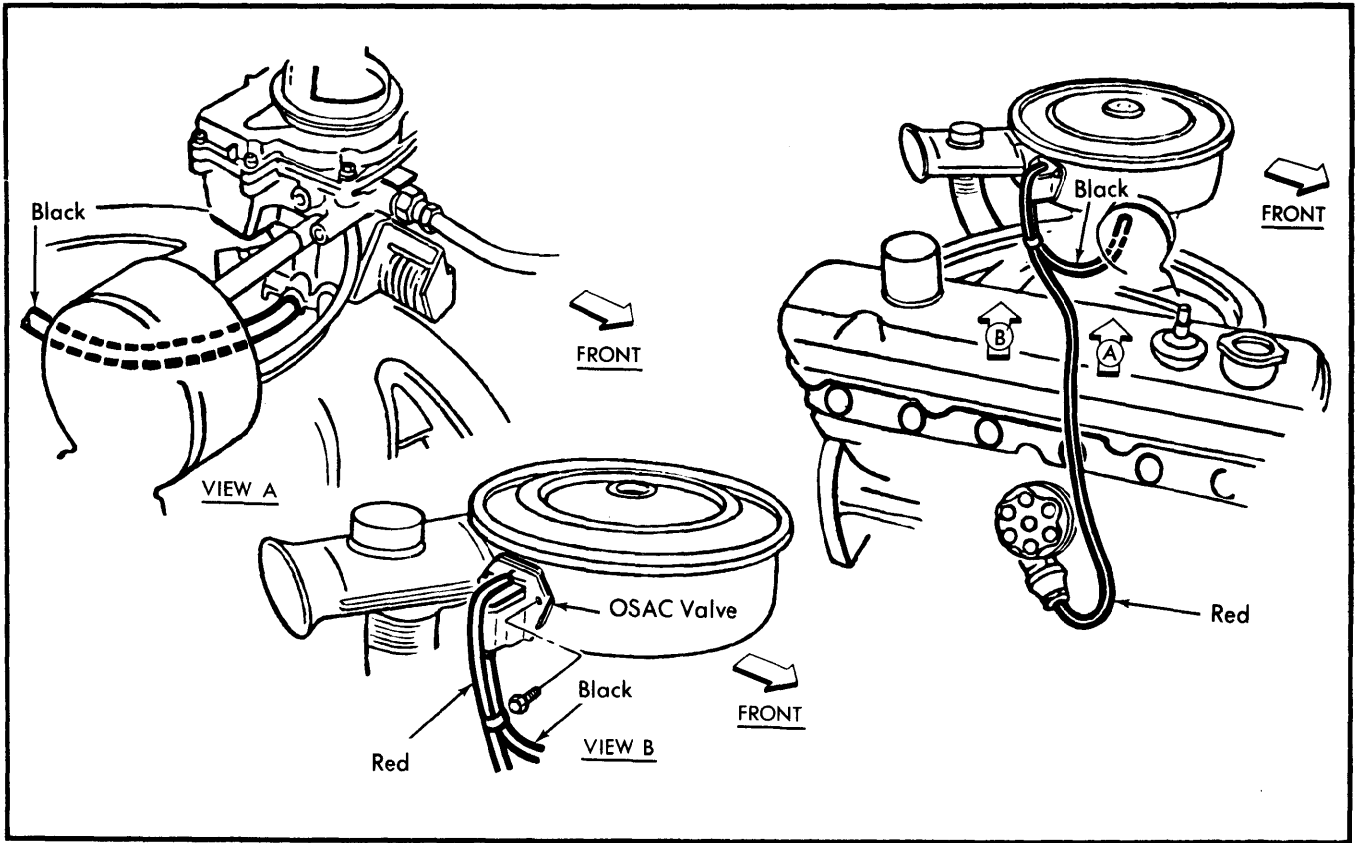

Fig. 1 OSAC Vacuum Hose System for 225" Engine (Light Duty Cycle)

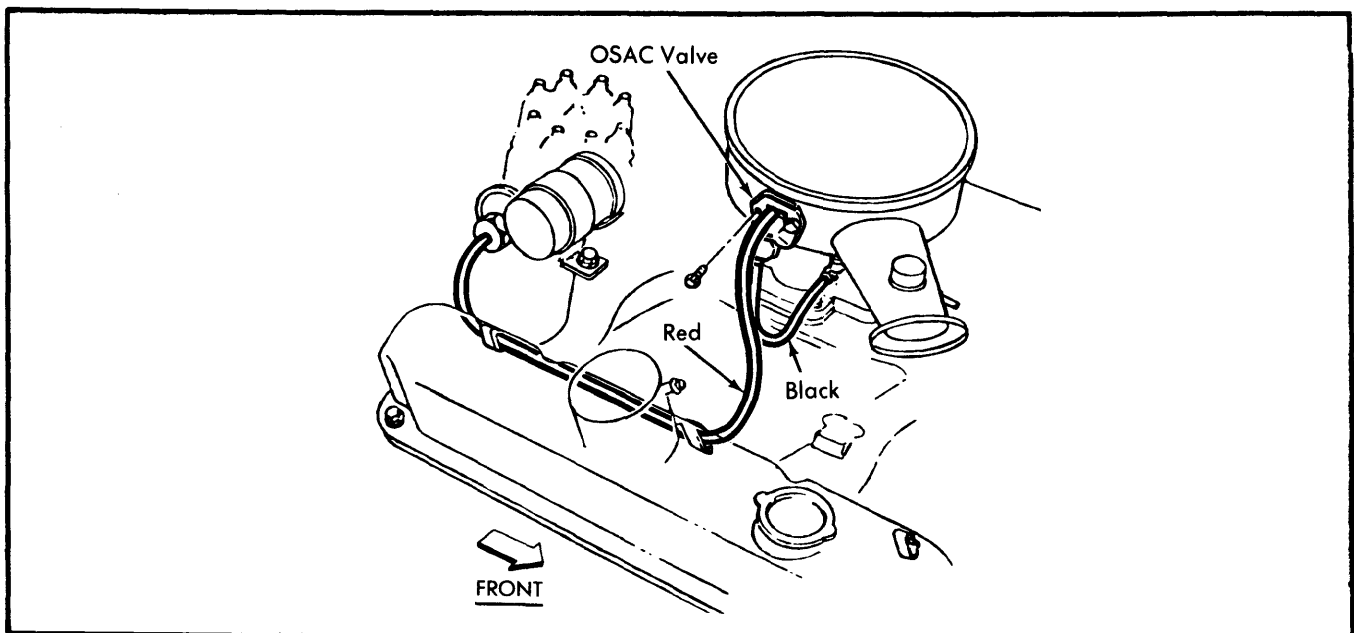

Fig. 2 OSAC Vacuum Hose System for 318" & 360" Engines (Light Duty Cycle)

1975-79 EXHAUST EMISSION SYSTEMS

1978 Chrysler Corp. Vacuum Diagrams (Cont.)

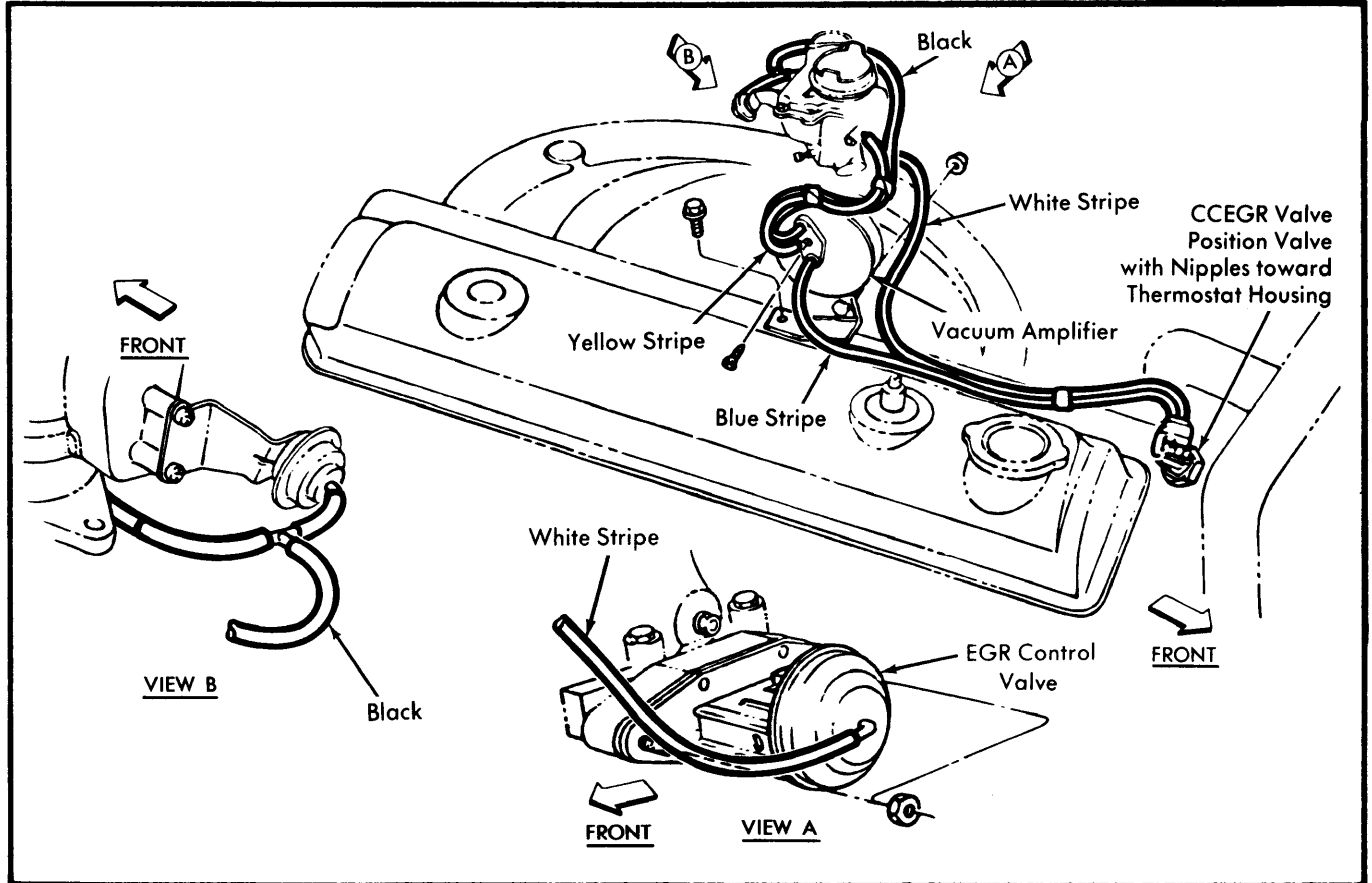

Fig. 3 EGR Vacuum Hose System for 225" Engine (Light Duty Cycle)

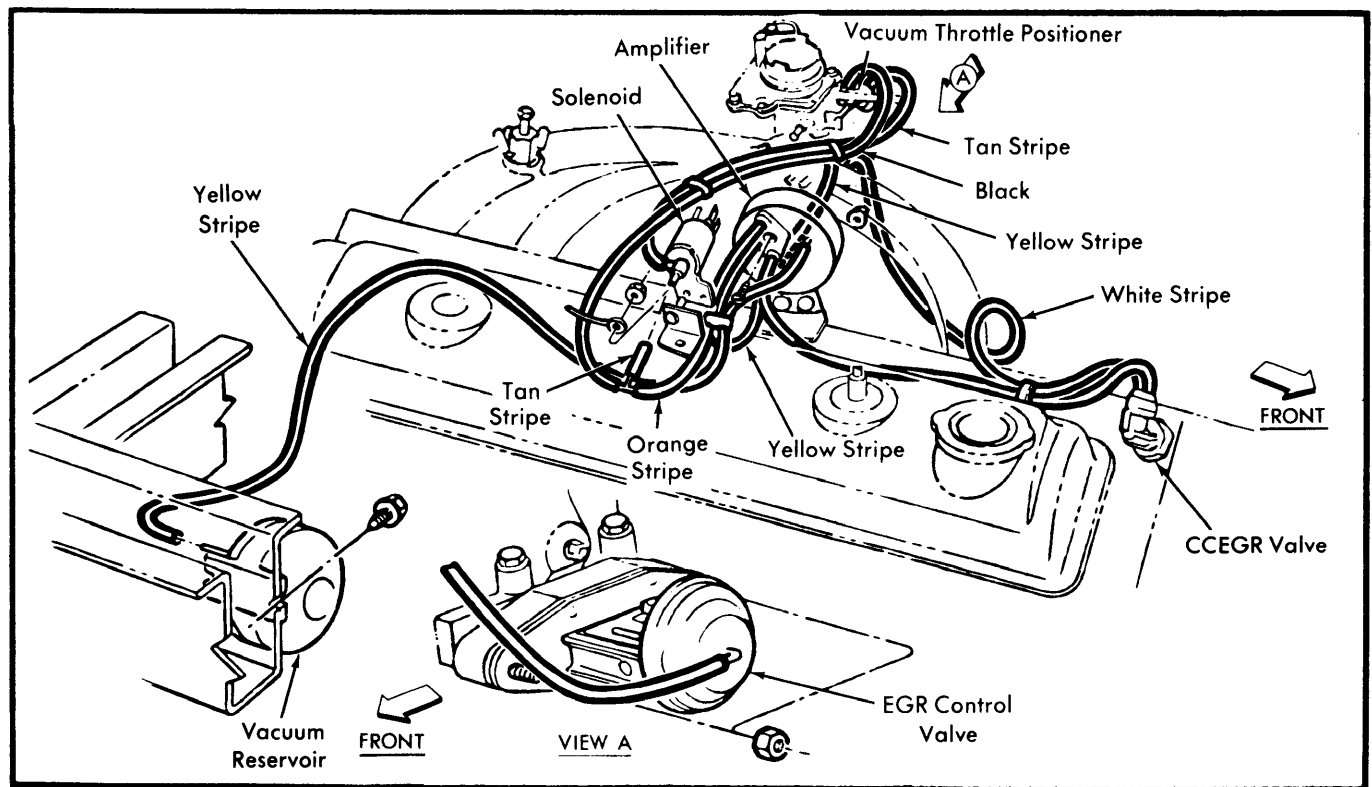

Fig. 4 EGR & Throttle Positioner Vacuum Hose System for 225" Engine (Heavy Duty Cycle Calif. Only)

1975-79 EXHAUST EMISSION SYSTEMS

1978 Chrysler Corp. Vacuum Diagrams (Cont.)

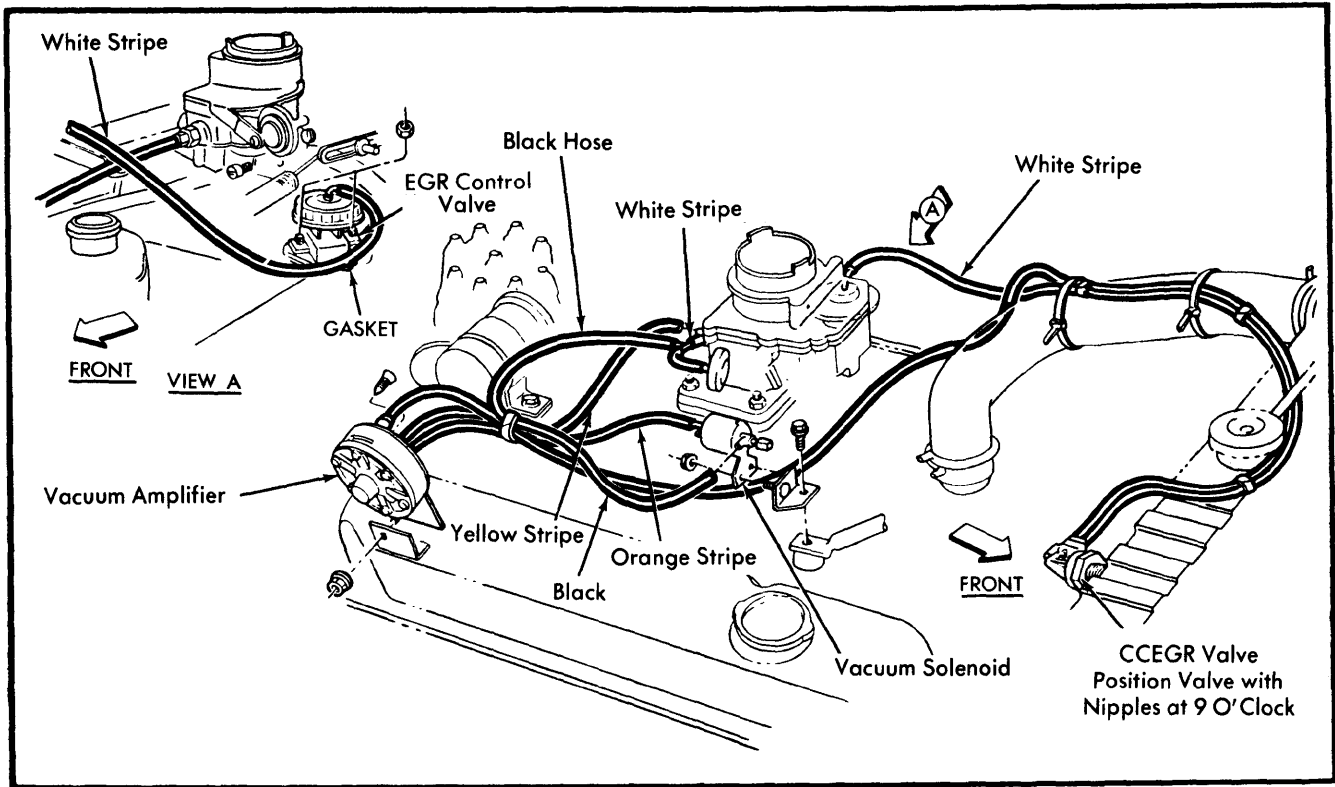

Fig. 5 EGR Vacuum Hose System for Man. Trans. 318ⁿ Engines (Light Duty Cycle)

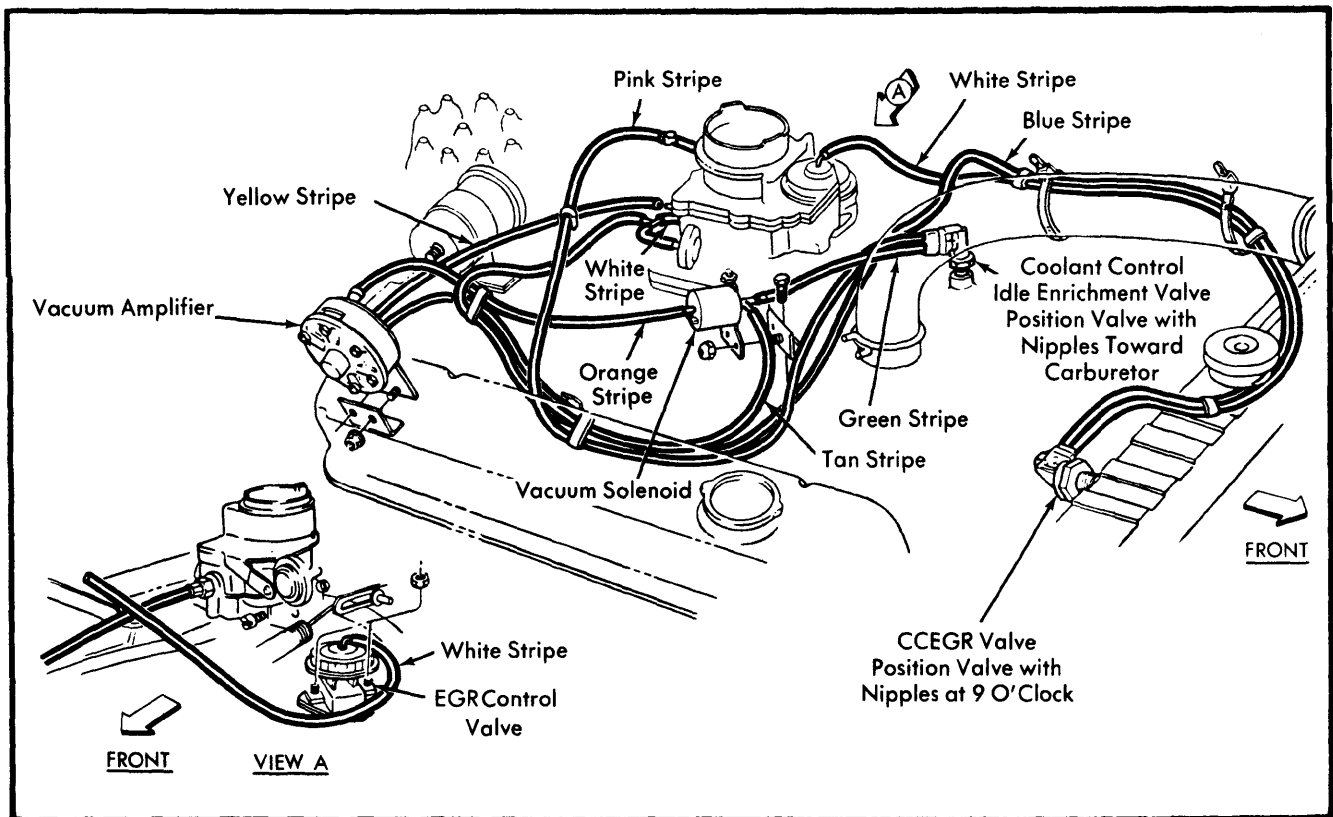

Fig. 6 EGR & Idle Enrichment Vacuum Hose System for Auto. Trans. 318ⁿ Engines (Light Duty Cycle)

1975-79 EXHAUST EMISSION SYSTEMS

1978 Chrysler Corp. Vacuum Diagrams (Cont.)

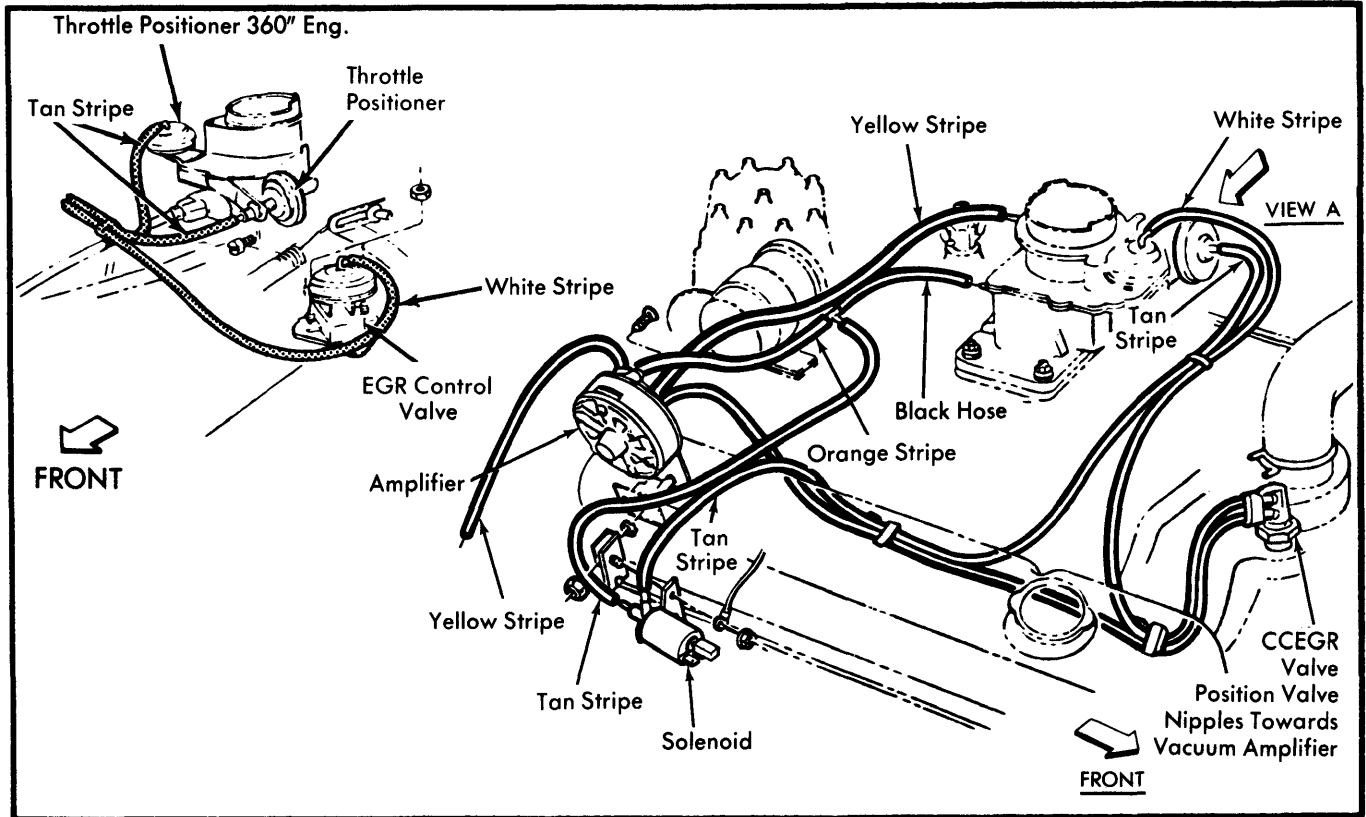

Fig. 7 EGR Vacuum Hose System for 318" & 360" Engines (Heavy Duty Cycle Calif. Only)

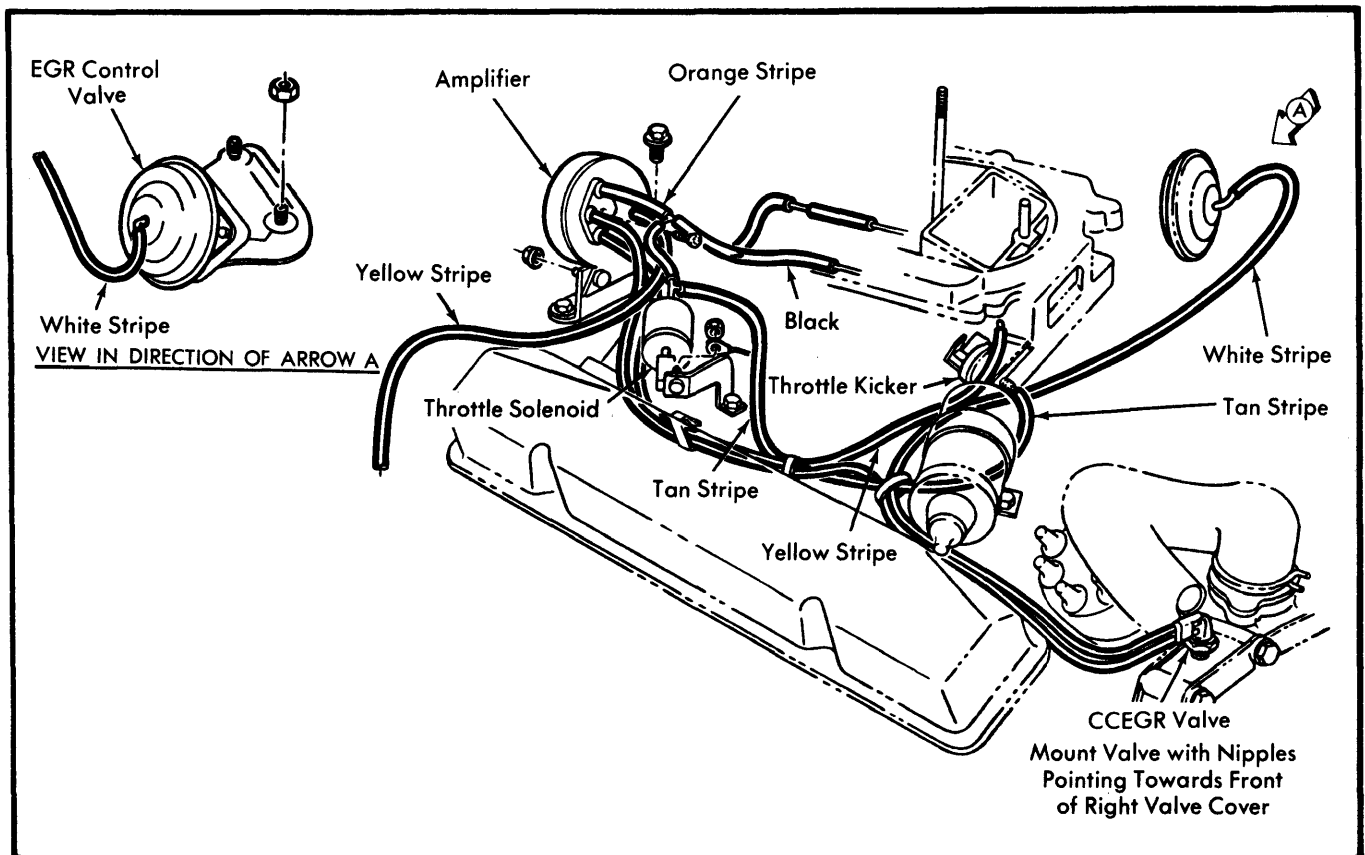

Fig. 8 EGR Vacuum Hose System for 440" Engine (Heavy Duty Cycle Calif. Only)

1975-79 EXHAUST EMISSION SYSTEMS

1978 Chrysler Corp. Vacuum Diagrams (Cont.)

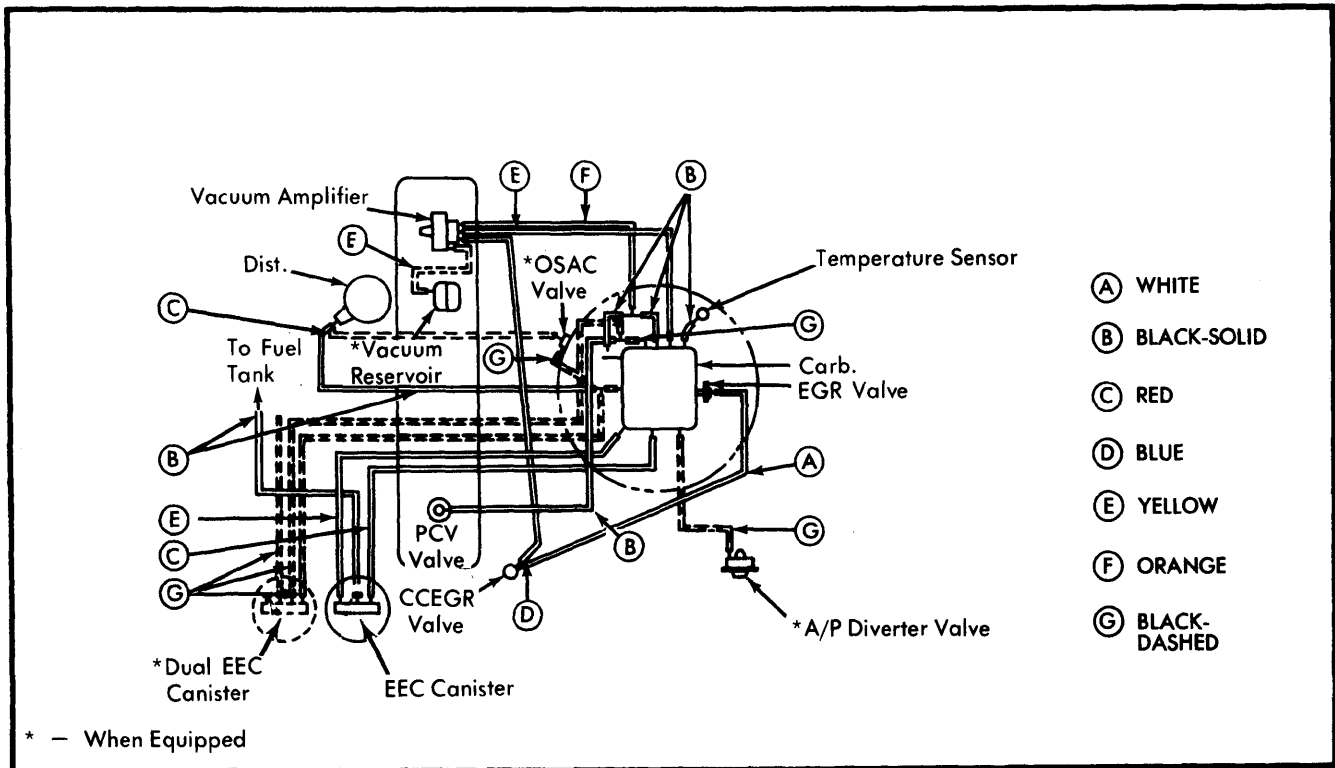

Fig. 9 Emission Vacuum House Routing for 225" Engines, Light Duty Vehicles (Voyager, Compact & Motor Homes Only)

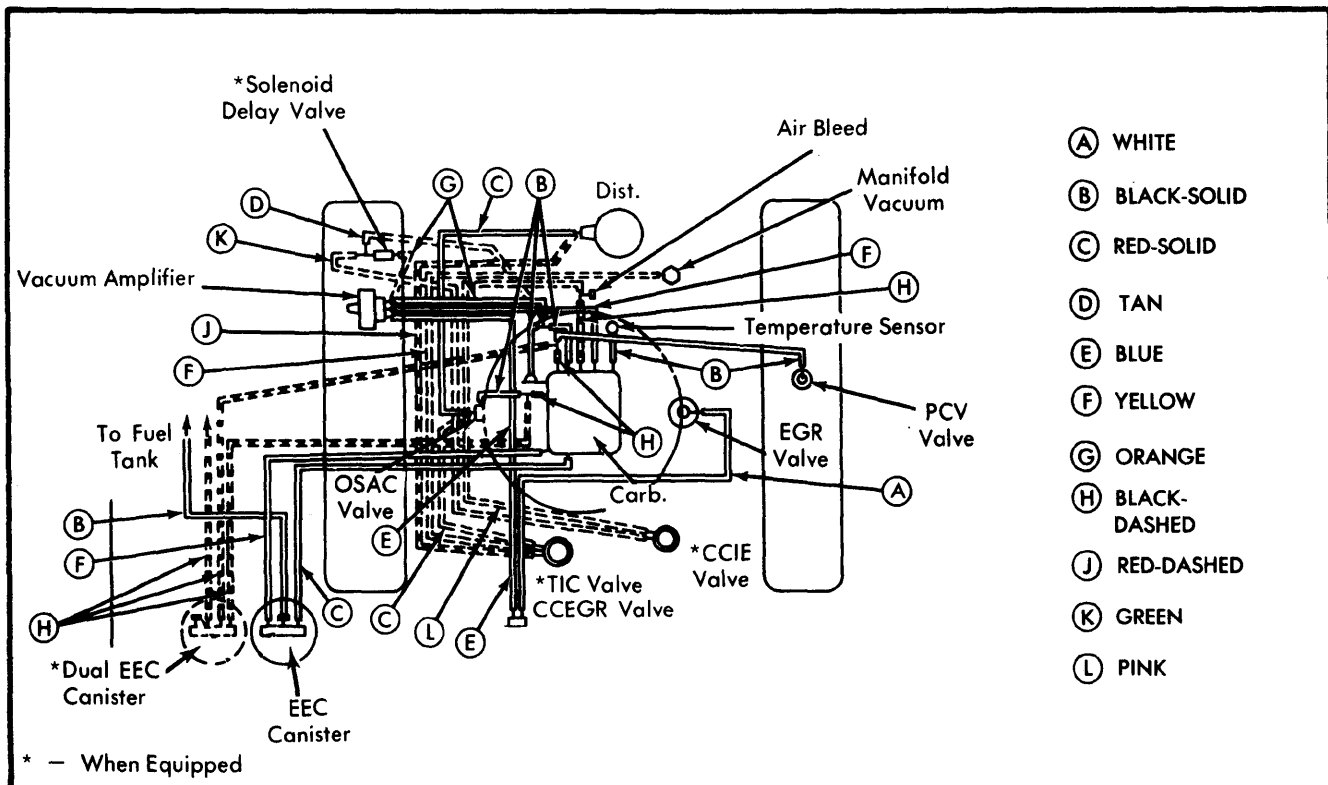

Fig. 10 Emission Vacuum Hose Routing for 318" & 360" 2-Bbl. Engines, Federal Light Duty Vehicles (Voyager, Compact & Motor Homes Only)

1975-79 EXHAUST EMISSION SYSTEMS

1978 Chrysler Corp. Vacuum Diagrams (Cont.)

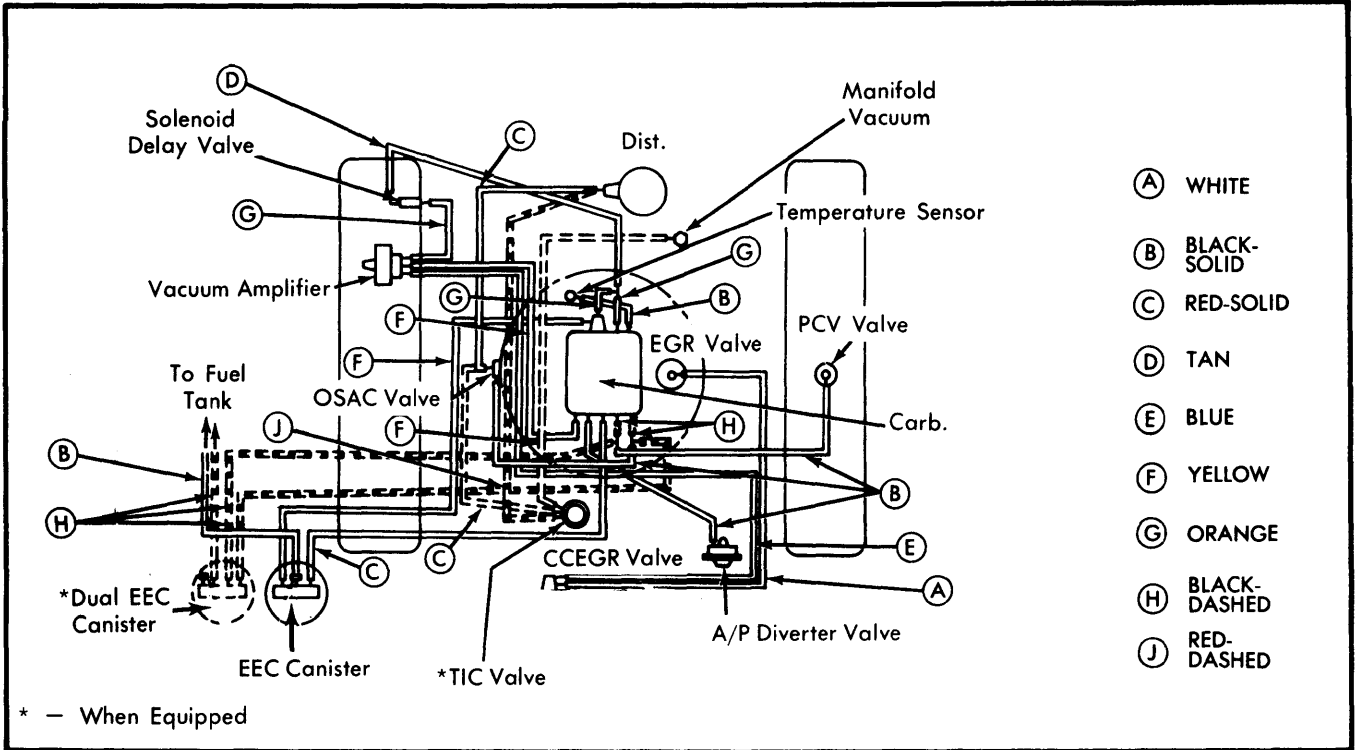

Fig. 11 Emission Vacuum Hose Routing for 360" 4-Bbl. Engines, Calif. Light Duty Vehicles (Voyager, Compact & Motor Homes Only)

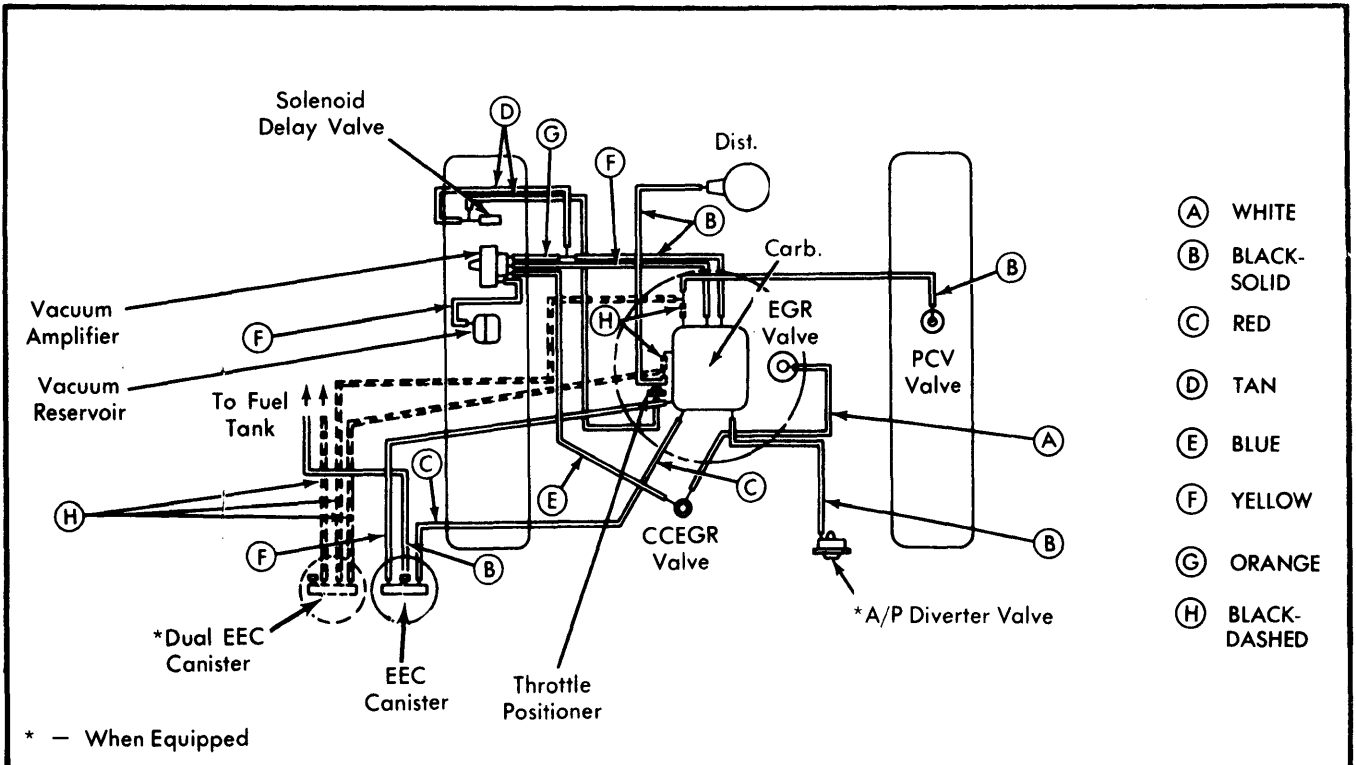

Fig. 12 Emission Vacuum Hose Routing for 360" 2-Bbl., Calif. Heavy Duty Vehicles (Voyager, Compact & Motor Homes Only)

1975-79 EXHAUST EMISSION SYSTEMS

1978 Chrysler Corp. Vacuum Diagrams (Cont.)

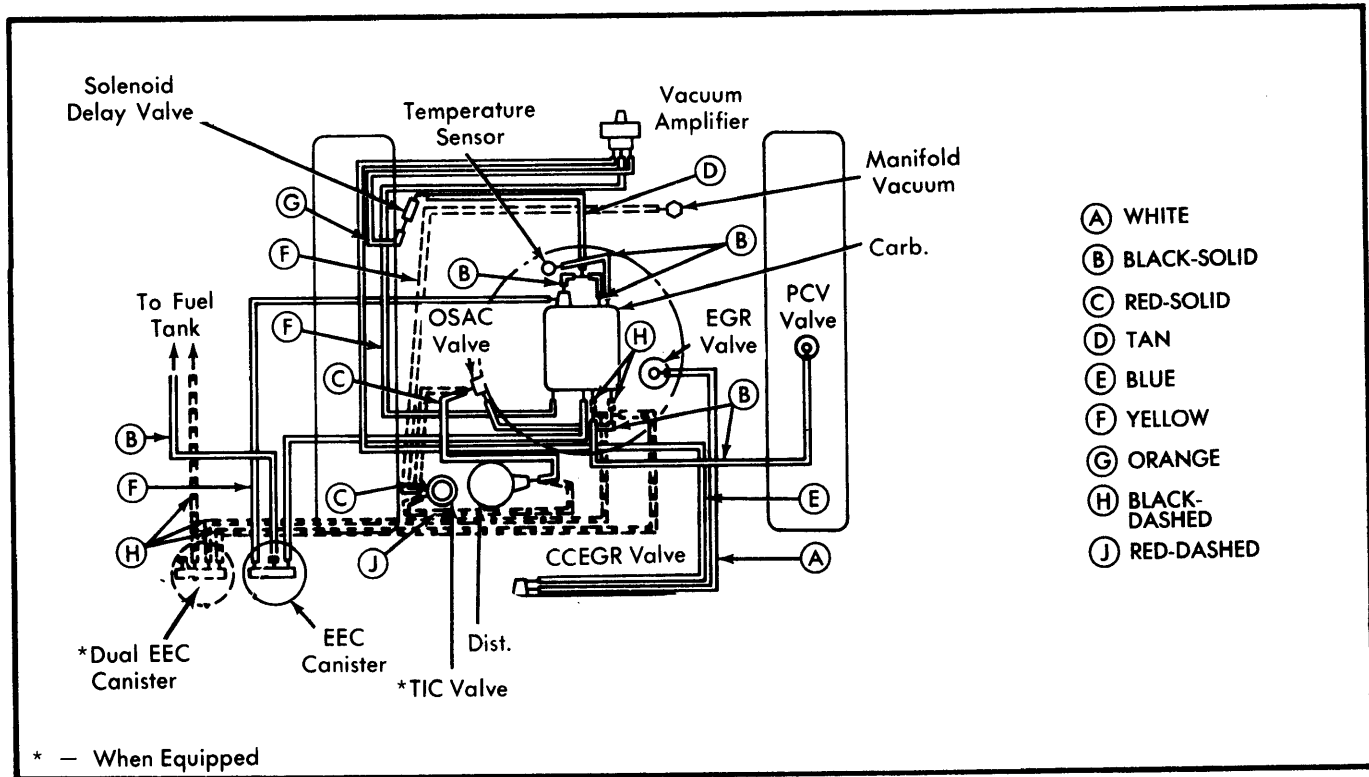

Fig. 13 Emission Vacuum Hose Routing for 440" Engines, Calif. Light Duty Vehicles (Voyager, Compact & Motor Homes)

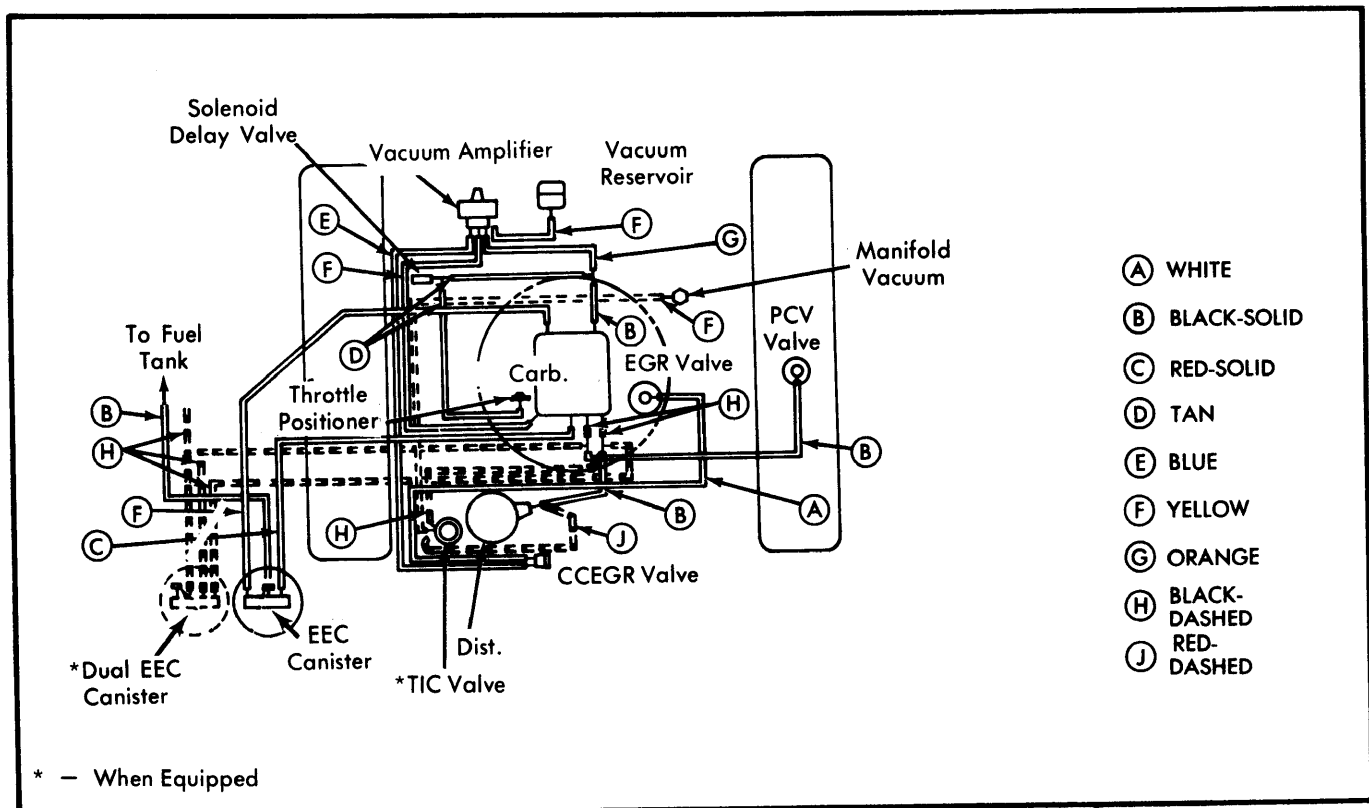

Fig. 14 Emission Vacuum Hose Routing for 440" Engines, Calif. Heavy Duty Vehicles (Voyager, Compact & Motor Homes Only)