

# 1975-79 EXHAUST EMISSION SYSTEMS

## Chrysler Corp. Vacuum Throttle Positioner

### DESCRIPTION

All Heavy Duty emissions models have a carburetor equipped with a vacuum throttle positioner. This system reduces unburned hydrocarbon (HC) emissions during periods of rapid deceleration. System consists of an electronic speed switch, a vacuum solenoid valve and a vacuum throttle positioner.

### OPERATION

The speed switch receives an ignition pulse through the ballast resistor, which is connected to the ignition control unit. It senses when engine speed is above 2,000 RPM, and energizes the throttle positioner. By energizing the throttle positioner, the plunger extends slightly and will hold the throttle blades open to 1750 RPM on sudden deceleration. This will prevent an overly rich mixture during deceleration.

When the speed switch senses that engine RPM has dropped below 2000 RPM, it de-energizes the positioner and throttle blades are allowed to return to normal idle position.

### ADJUSTMENT

1) Start engine and accelerate to about 2000 RPM. Verify throttle positioner operation. Throttle positioner must withstand hand pressure. Manually open throttle until engine reaches a speed of approximately 2500 RPM on "M" models, 2000 RPM on all other models. Loosen lock nut and adjust throttle positioner until it just contacts throttle lever.

2) Release throttle lever, then slowly adjust positioner until a sudden drop in speed occurs (over 1000 RPM). At this point, continue adjusting positioner in a decreasing direction for an additional ¼ turn and tighten lock nut. Accelerate engine until it reaches a speed of approximately 2300 RPM on "D" and "W" models, 2500 RPM on all other models, and release throttle. Engine should return to normal idle speed.

### TESTING

1) Check all wiring and hose connections in system. Repair or replace as necessary. Apply vacuum from an external source to

vacuum throttle positioner. If positioner does not extend, replace it. If positioner extends, pinch off vacuum hose and observe plunger. If plunger remains extended for one minute or more, unit is okay.

2) Apply external vacuum to the manifold supply hose connection on the solenoid valve. Disconnect wiring harness from solenoid and ground one terminal of the solenoid. Connect 12 volt source to the other terminal. Watch throttle positioner. If plunger does not cycle as voltage is applied, replace solenoid. If solenoid checks okay, replace speed switch.

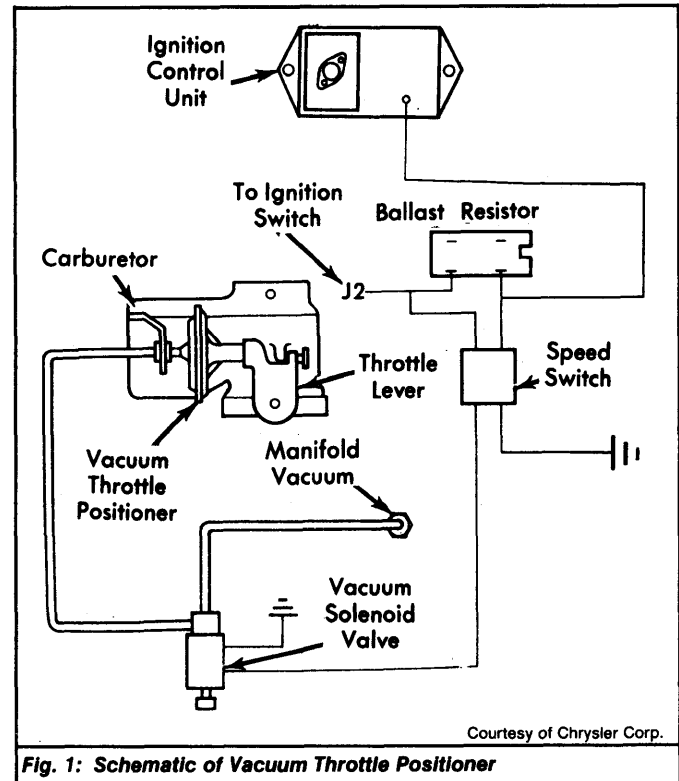

Fig. 1: Schematic of Vacuum Throttle Positioner