

1975-79 FUEL SYSTEMS

Chrysler Corp. Diesel Fuel Injection

2-125

1978-79 243" 6-Cylinder Diesel Engine Equipped Models

DESCRIPTION

The feed pump draws filtered fuel from tank, through two additional filters, and supplies it to the injection pump. At proper intervals, the injection pump forces high pressure fuel into injector lines. High pressure fuel is sprayed into the combustion chamber through nozzles. Fuel not used during operation is drawn off the leakoff lines and returned to fuel tank.

Fuel system operation during starting, stopping and high speed is controlled by the Electrical Diesel Injection Control (EDIC) system. System consists of key switch, fuel control relay operated by key switch, fuel control motor, capsule rod and injection pump.

OPERATION

INJECTION PUMP

A fixed-stroke, plunger-type injection pump is used in this system. Fuel is injected at high pressure into the injector lines by movement of plunger in plunger barrels. Delivery valves at top of plunger barrels prevent fuel from flowing back from high pressure pipes to injection pump and from draining from nozzle tips after injection has ended. See Fig. 1. Injection pumps are serviced only as an assembly.

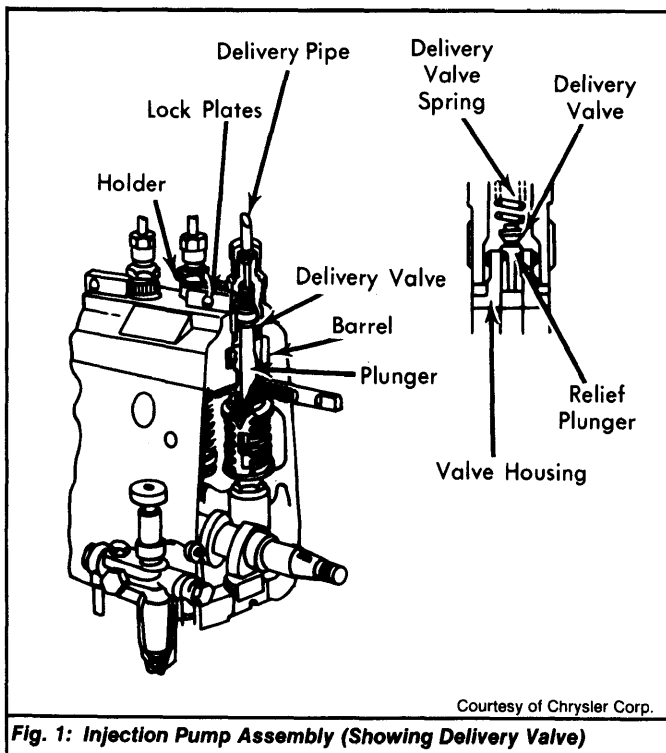

GOVERNOR

A mechanical governor is mounted at the back of injection pump housing. This governor regulates amount of fuel injected by controlling movement of injection pump control rack and sleeve proportional to engine speed.

AUTOMATIC TIMER

A gear-type automatic timer, mounted on front of the injection pump camshaft, advances injection timing as engine speed increases to ensure injection of fuel at the proper intervals. See Fig. 2.

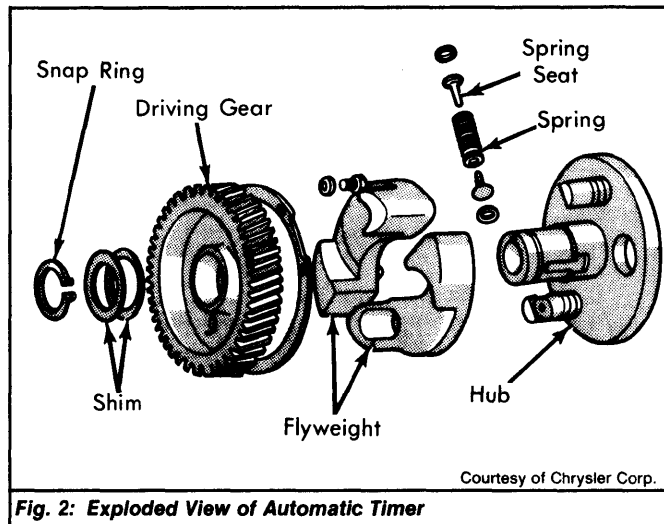

INJECTION NOZZLES

Fuel from injection pump enters upper part of the nozzle holder and flows into fuel reservoir in nozzle through a passageway. The nozzle tip atomizes the high pressure fuel and sprays it into the pre-combustion chamber. Without fuel pressure, a needle valve holds the nozzle tip orifice closed. Fuel delivered at specified pressure overcomes spring pressure and needle valve opens. As pressure drops off, valve closes. Remaining fuel in nozzle is bled off through leakoff pipe. See Fig. 3.

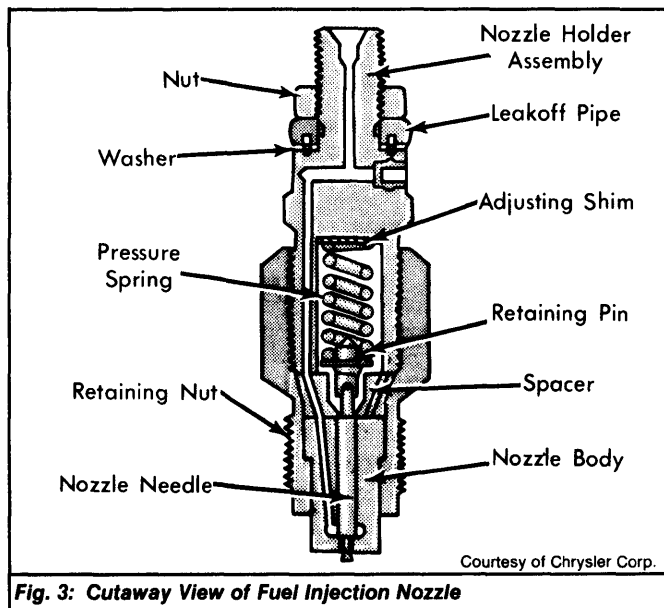

ELECTRICAL DIESEL INJECTION CONTROL

When key switch is turned to "START" position, the starter begins to crank engine. The fuel control relay actuates the fuel control motor which pulls the injection pump stop lever to "START" position, compressing spring in spring capsule on top of governor.

With key switch in "START" position, fuel control motor continues to revolve, transmitting movement to the stop lever. When the stop lever is moved to START position, it restricts movement of capsule control rod and stop lever. See Fig. 4.

The motor continues to rotate through the control assembly clutch, which prevents damage to rotating parts. When engine starts, key switch is returned to "ON" position. The on signal at fuel control relay reverses control motor rotation, returning stop lever to drive position.

1975-79 FUEL SYSTEMS

Chrysler Corp. Diesel Fuel Injection (Cont.)

With ignition switch turned from "ON" to "OFF" position, the fuel control relay actuates the control motor to push injection pump lever to the stop position. This cuts off power to motor. The capsule rod with enclosed spring permits drive lever to push rod after stop lever reaches the stop position. This means the motor stop position may overrun the stop lever stop position to ensure positive shutoff.

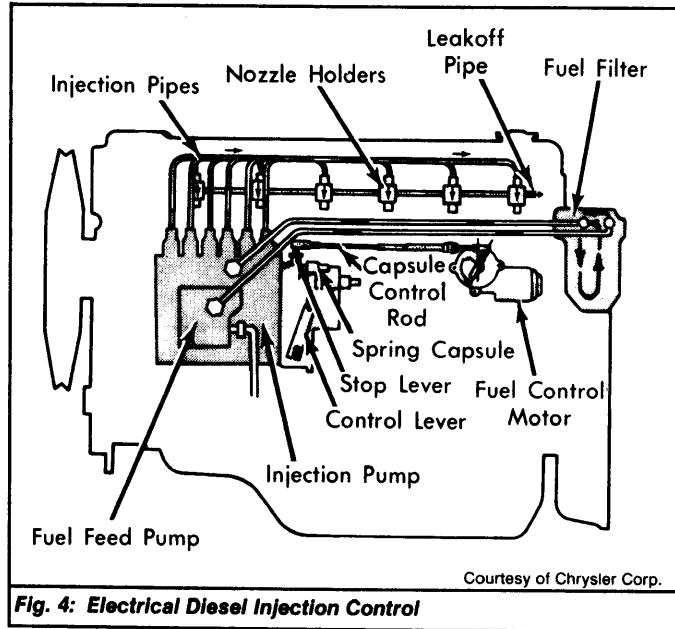

Fig. 4: Electrical Diesel Injection Control

TROUBLE SHOOTING

NO START

No Fuel Reaching Injection Pump - Air trapped in fuel system. Fuel line drawing air. No fuel in tank. Strainer at pump inlet, fuel line, or fuel filter clogged. Feed pump not delivering fuel.

Fuel Reaching Injection Pump - Pump seized or loose on mounting. Control rack seized, plunger stuck to barrel, or control sleeve stuck.

Slight Exhaust Smoke, Insufficient Fuel Injected - 1) Delivery valve stuck or spring broken. Air trapped in fuel system. Strainer at feed pump inlet, fuel line or filter clogged. Feed pump delivering insufficient fuel. Control rack movement restricted.

2) Accelerator linkage binding. Injector line connector loose. Injection pump tappet sticking or tappet roller or cam worn excessively. Tappet plunger stuck or broken or plunger excessively worn. Control pinion set screw loose.

Thick Exhaust Smoke, Incorrect Injection Timing - Injection pump improperly timed. Pump tappet or cam worn excessively, throwing timing off. Pump adjusting bolt loose, throwing timing off.

Nozzle Does Not Spray Fuel Properly - Needle valve stuck in nozzle body, nozzle remains open. Needle valve not seating properly, allowing fuel to leak. Injection pressure too low. Nozzle holder spring broken or nozzle packing clogged.

ENGINE POWER OUTPUT INSUFFICIENT

1) See SLIGHT EXHAUST SMOKE, INSUFFICIENT FUEL INJECTED under NO START trouble shooting. If exhaust smoke is White, check fuel viscosity to ensure it flows freely. Also check for improper injection interval, or loose pump tappet adjusting bolt.

2) If exhaust smoke is Black, check for improper injection interval, clogged air cleaner or restricted air intake. If Black smoke is accompanied by non-uniform fuel charge between cylinders, check pump's tappet roller or cam timing, loose tappet adjusting bolts, stuck tappets, worn or stuck plungers and loose control pinion set screws. Insufficient power could also be due to improper nozzle spray pattern.

EXCESSIVE SMOKE DURING OPERATION

If thick White smoke, injection timing could be retarded or check for water in fuel. If thick Black smoke, injection timing may be advanced or excessive fuel delivered from injection pump. Also check for non-uniform fuel delivery, poor spray pattern from nozzles and clogged air cleaner.

ENGINE SPEED NOT SMOOTHLY CONTROLLED

If engine runs at high speed and will not stop, check accelerator linkage for binding. Defective governor linkage. Injection pump rack binding or control pinion set screw loose.

TESTING

SPRAY PATTERN TEST

NOTE: Nozzles are throttle-type, which inject fuel into precombustion chamber in two stages, throttled injection and main injection. Carefully note nozzle reaction during each injection stage during test.

Throttle Injection - 1) Install nozzle holder and tip on nozzle tester. Operate injection tester lever at the rate of one stroke per second. Spray should be a coarse mist which does not deflect from nozzle axis. See Fig. 5.

2) A drop of fuel remaining on nozzle tip after throttled injection test is normal and does not indicate defective nozzle.

Main Injection - 1) Operate tester lever at the rate of five or six times per second. Fuel should be sprayed in finely atomized particles.

2) Fuel must be sprayed in a 4 degree cone that does not deflect from axis of nozzle. After end of main injection, no after drip should remain on tip. If drop is present, operate lever several times. If drop remains, replace nozzle.

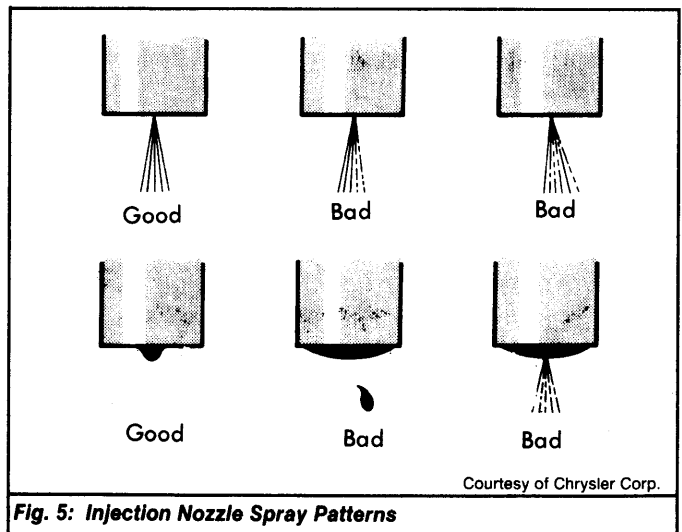

Fig. 5: Injection Nozzle Spray Patterns

INJECTION NOZZLE INTEGRITY TEST

Ensure injection nozzle is properly adjusted. See INJECTION NOZZLE ADJUSTMENT in this article. Slowly and steadily increase pressure on tester to 1429 psi (100.5 kg/cm²). Hold pressure and inspect nozzle to be sure there are no fuel leaks. If leaks are present, replace nozzle tip.

INJECTION PUMP TEST

1) If nozzle tests show nozzles within specification, but combustion is uneven, loosen cap nut on a fuel injection line at injection pump output. This relieves pressure and prevents fuel injection into cylinders.

1975-79 FUEL SYSTEMS

Chrysler Corp. Diesel Fuel Injection (Cont.)

2) If cylinder is misfiring, go from cylinder to cylinder until faulty cylinder is located. Perform cylinder compression test. If compression is good on faulty cylinder, replace injection pump.

"START" POSITION TEST

Turn ignition switch to "START" position. The control motor should move the injection pump stop lever to start position. See Fig. 6.

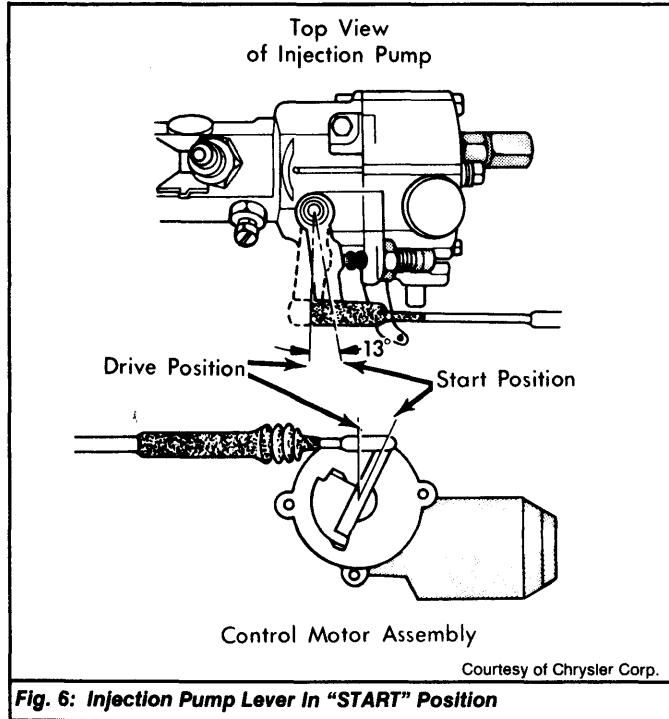

"DRIVE" POSITION TEST

Start engine and inspect position of drive lever. The end of drive lever at motor should be positioned between the two match marks. See Fig. 7.

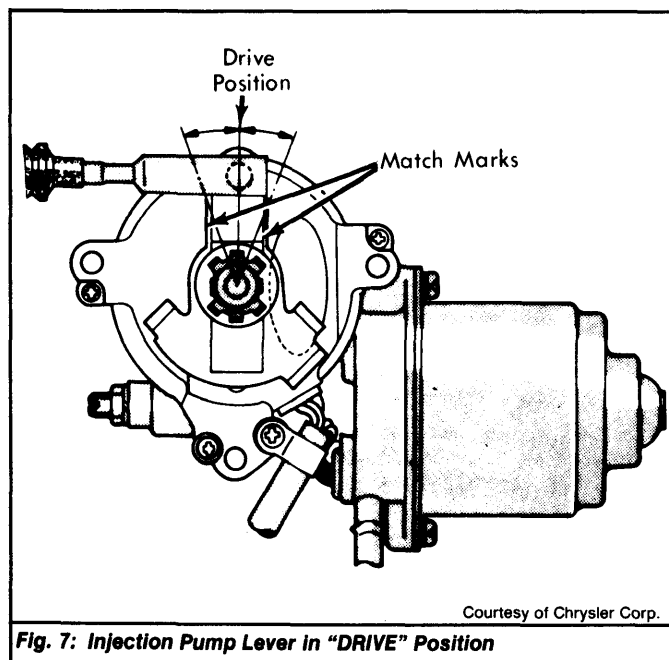

"STOP" POSITION TEST

Turn ignition switch to "OFF" position. Injection pump lever should move to the stop position and engine should stop. See Fig. 8.

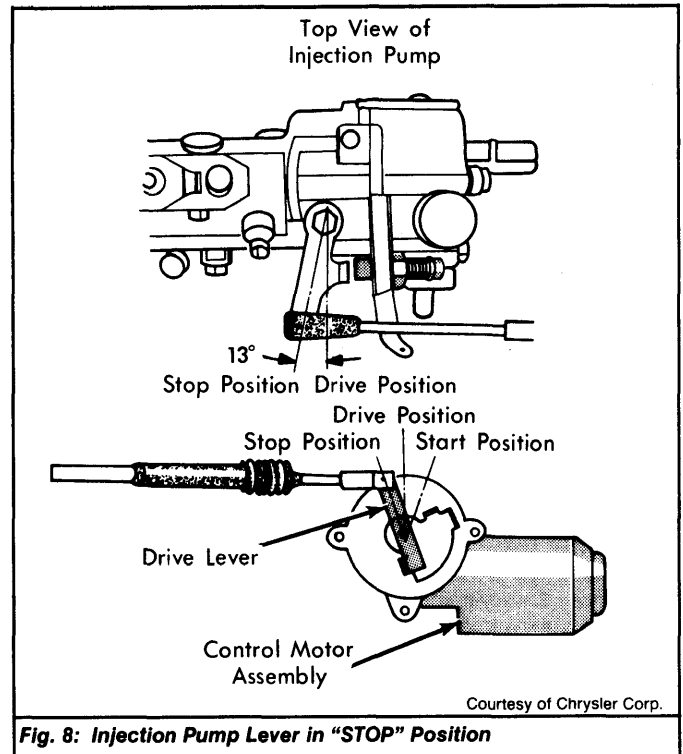

FUEL CONTROL RELAY TEST

- 1) Remove connector from fuel control relay. Measure resistance between terminals on relay connector socket with an ohmmeter. See FUEL CONTROL RELAY TEST table. If resistance values are incorrect, replace fuel control relay and retest.
- 2) If values are correct, apply 12 volts between terminals No. 4 and 6. See Fig. 9. Measure resistance between terminals No. 1 and 8. Resistance should be infinite. If not, replace relay.
- 3) If resistance is correct, apply 12 volts between terminals No. 5 and 6. Measure resistance between terminals No. 1 and 3. Resistance should be zero Ohms. If resistance is other than zero, fuel control relay should be replaced.
- 4) If resistance is correct, apply 12 volts between terminals No. 6 and 7. Measure resistance between terminals No. 3 and 6, and between terminals No. 1 and 2. In each case, resistance should be zero ohms. If resistance is correct, fuel control relay is good. If not, replace relay.

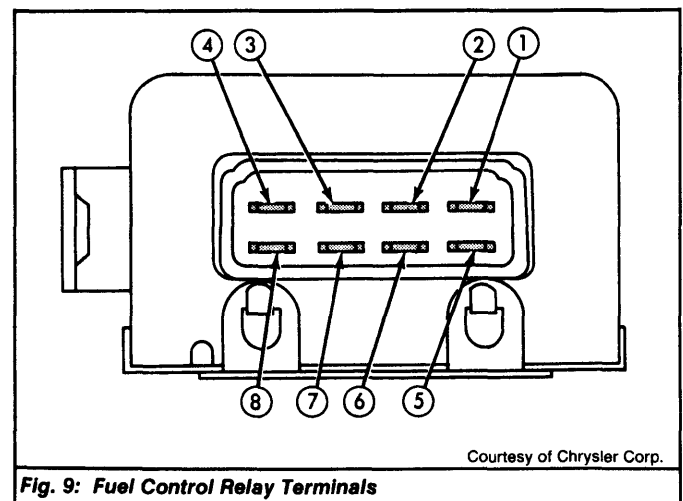

1975-79 FUEL SYSTEMS

Chrysler Corp. Diesel Fuel Injection (Cont.)

FUEL CONTROL MOTOR CLUTCH UNLOCK TORQUE

Check the unlock clutch torque on fuel control motor assembly with torque wrench. Unlocked torque should measure 35-52 INCH lbs. (3.9-5.8 N.m). If not within specifications, replace fuel control motor.

REMOVAL & INSTALLATION

INJECTION PUMP

Removal - 1) Disconnect batteries and fuel shutoff rod at stop lever. Remove power steering pump and bracket from engine and set aside. Clean any foreign material away from fuel line, hose fittings and injection pipes at injection pump.

2) Drain engine oil and remove dipstick and tube. Disconnect throttle cable and linkage from injection pump control lever. Remove throttle control bracket assembly and disconnect fuel supply line to feed pump.

3) Disconnect fuel hoses leading to filter and from injection pump. Cover all openings prevent entry of any dirt. Turn crankshaft until No. 1 piston is positioned approximately 7 degrees BTDC on compression stroke.

4) Pointer should be midway between TDC and the 14 degree line on crankshaft damper. Disconnect injection pipes from delivery valves. Cap valves. Disconnect injection pump lube line at crankcase fitting near front of starter motor.

5) Remove 5 screws and one bolt holding injection pump to engine. Pull pump rearward to disengage from engine front plate and timing gear case. Twist pump toward block and continue pulling rearward until automatic timer is free of case.

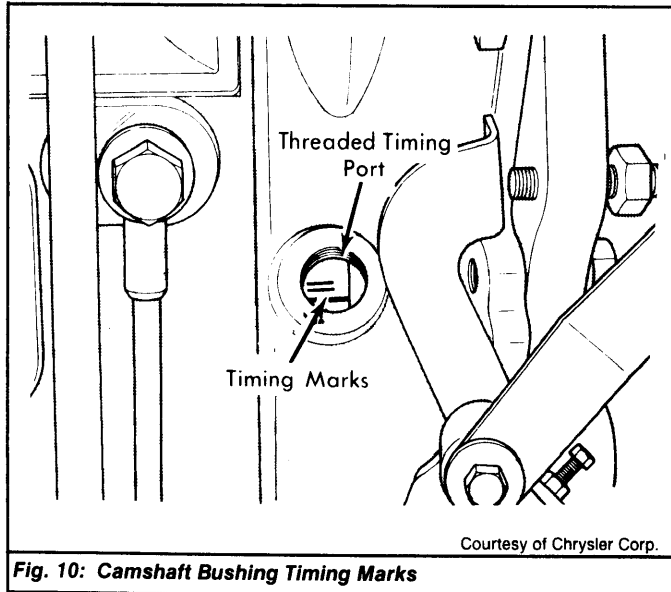

Installation - 1) Loosen 4 nuts attaching injection pump to mounting flange plate. Align center timing mark on pump flange with pointer on plate.

2) Be sure "O" ring is in place on forward face of pump mounting flange. Remove timing port plug on governor housing behind control lever to expose camshaft bushing timing mark. See Fig. 10.

3) Turn pump drive gear to align timing mark on camshaft bushing with pointer on governor. Guide plate notch on drive gear will be approximately at 8 o'clock position as viewed from front.

4) Ensure crankshaft is still positioned at approximately 7 degrees BTDC. Insert automatic timer into gear case. Turn injection pump in against block, then turn drive gear clockwise or counterclockwise to mesh drive gear and idler gear. See Fig. 11.

NOTE: Do not force pump into position. If pump cannot be pushed forward manually, the mesh is incorrect. Retract pump and turn drive gear as needed to achieve proper mesh.

5) Push pump forward into timing gear case and turn away from block to align attachment holes. Attach pump to timing gear case. Turn crankshaft counterclockwise until it reaches specified injection timing point.

6) Governor pointer and pump camshaft bushing timing marks should now be aligned. When timing marks are aligned, install governor housing timing port plug.

7) Reverse removal procedure to complete installation. DO NOT connect No. 1 injection pipe or batteries until system has been bled of air and injection timing has been checked and adjusted. See INJECTION PUMP TIMING in this article.

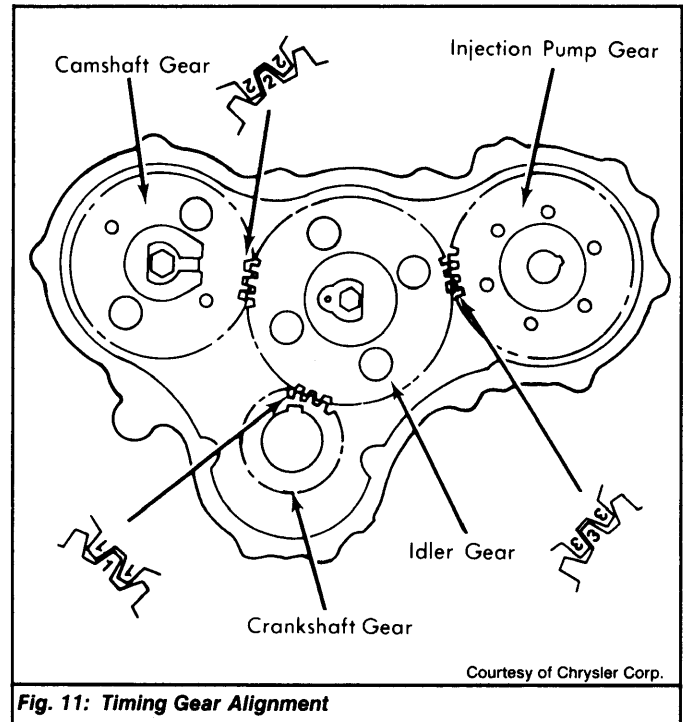

NOZZLE HOLDER

Removal & Installation - Disconnect injector line from nozzle holder at cylinder. Remove nozzle holder and nozzle assembly. To install, reverse removal procedure.

OVERHAUL

INJECTION PUMP

NOTE: Injection pump is serviced as an assembly only. If pump malfunctions, pump must be replaced.

Disassembly - Mount pump in a soft-jawed vise. Remove nut from injection pump shaft. Install Timer Remover/Installer (MH-061097) over timer. Pull drive gear and automatic timer from injection pump shaft. Disassemble timer.

Assembly - Using timer remover/installer, install drive gear and automatic timer assembly. Gear mark must be aligned with drive gear keyway and plate notch aligned with "3" on gear. See Fig. 11.

INJECTION NOZZLES

Disassembly - Place nozzle holder in vise. Tighten vise around retaining nut and remove nozzle holder body from nut. Lift pressure adjusting shim, pressure spring, retaining pin, spacer and nozzle tip from holder.

Inspection - 1) Immerse nozzle tip in clean fuel oil and operate needle valve manually. If valve binds in tip, replace tip.

1975-79 FUEL SYSTEMS

Chrysler Corp. Diesel Fuel Injection (Cont.)

2-129

2) Use magnifying glass to inspect nozzle tip. Check for roughness or irregularities. Check clearance between needle valve and tip orifice. If clearance is distorted, replace tip.

3) Inspect valve tip and pressure pin contact area. Replace nozzle if valve tip is deformed or if pressure pin contact areas are unevenly worn.

4) Visually inspect pressure spring for squareness, cracks or breakage. Replace if defective. Inspect spring seat and needle valve contact area. Replace if defective.

Reassembly - To reassemble, reverse disassembly procedure.

ADJUSTMENTS

INJECTION PUMP TIMING

Primary Method - 1) Disconnect batteries and fuel shutoff rod at injection pump stop lever.

2) Clean any foreign matter from No. 1 delivery valve, injection pipe and adjacent pump area.

3) Turn crankshaft clockwise to place No. 1 piston at TDC of compression stroke. Crankshaft position is identified by alignment of degree lines on damper rear face and pointer on bottom of timing gear case.

4) Turn crankshaft clockwise approximately 1 3/4 turns and disconnect No. 1 injection pipe from delivery valve.

5) Remove lock plates from No. 1 delivery valve holder and carefully unscrew holder from pump to avoid loss of valve spring and shims.

6) Remove valve spring and shims. Reinstall delivery valve holder snugly. Connect clean plastic tube into open end of delivery valve holder and direct other end into container.

NOTE: Injection pump control lever must be in idle position when performing steps 7) through 9).

7) Turn crankshaft clockwise approximately 30 degrees BTDC. Unscrew handle of priming pump on fuel feed pump to unlock. See Fig. 12.

8) Operate pump until fuel flows through plastic tube. Turn crankshaft one (1) degree. Stroke priming pump again. Repeat until no fuel flows in tube.

9) Read crankshaft angular position from damper scale. This is injection timing point.

10) If timing point is not to specifications, 18 degrees BTDC, loosen 4 pump-to-flange plate nuts and rotate pump. Move toward block to

advance timing and away from block to retard timing. The crankshaft angle varies by 6 degrees per division on pump flange plate scale. See Fig. 13.

11) Tighten pump-to-flange plate nuts and repeat steps 4) through 10). Remove plastic tube. Ensure delivery valve spring and valve are free of foreign matter and reinstall in holder. Tighten holder to 18-25 ft. lbs. (130-180 mkg). Reinstall lock plate.

12) Install No. 1 injection pipe to delivery valve holder and tighten to specifications. To lock priming pump handle, depress cover and screw in. Reconnect fuel shutoff rod and batteries. Start engine and check for leaks.

Alternate Method - 1) Disconnect batteries and fuel shutoff rod at injection pump stop lever. Clean area around delivery valves, injection pipe and pump.

NOTE: This method will allow accurate determination of timing point without disturbing the delivery valve.

2) Turn crankshaft clockwise to place No. 1 piston at TDC of compression stroke. Check alignment between pointer on bottom of timing gear case and degree lines on damper rear face.

3) Turn crankshaft clockwise approximately 1 3/4 turns. Disconnect No. 1 injection pipe from delivery valve.

4) Turn crankshaft clockwise in small steps. Stop when fuel begins to flow from delivery valve holder. Injection begins at this point.

NOTE: Control lever must be in idle position.

5) Read injection timing point from scale on back of crankshaft damper. If injection timing is correct, timing should be at the standard value as shown on Emission Control Tune-Up Decal minus 2 degrees.

NOTE: When alternate method is used, 2 degrees of crankshaft rotation will be taken up in delivery valve delay. Therefore, timing point should be at standard value minus 2 degrees if set correctly.

6) If timing point determined by this method differs from standard value minus 2 degrees, adjust injection timing as described in steps 10) through 12) of PRIMARY METHOD.

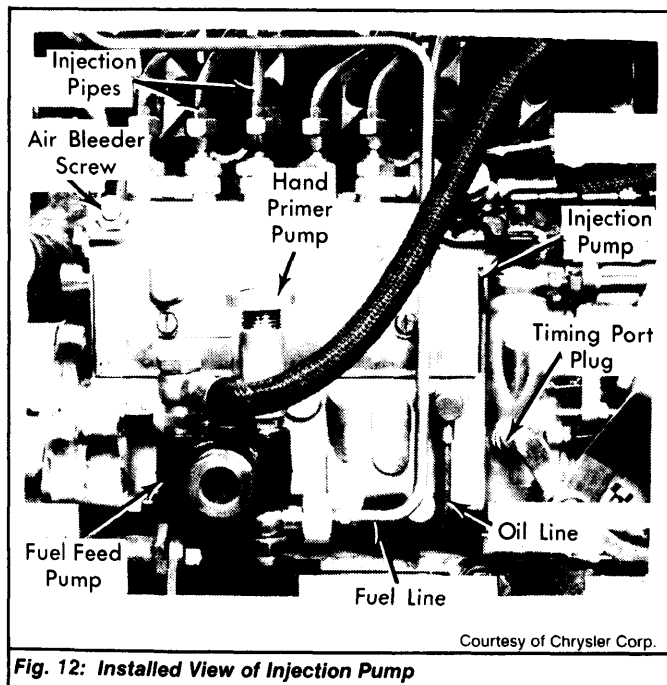

Fig. 12: Installed View of Injection Pump

Courtesy of Chrysler Corp.

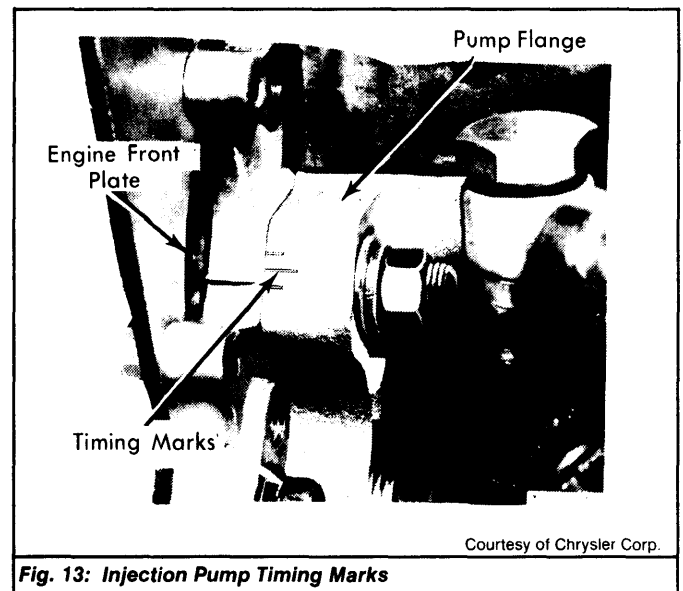

Fig. 13: Injection Pump Timing Marks

Courtesy of Chrysler Corp.

CAPSULE CONTROL ROD ADJUSTMENT

1) Check capsule rod installation at control motor drive lever. Place injection pump lever in drive position. The drive lever at motor should be between marks. See Fig. 14.

2) Turn drive lever with screwdriver until it is pointing straight upward. Disconnect capsule rod, ensuring pump stop lever is in drive position.

1975-79 FUEL SYSTEMS

Chrysler Corp. Diesel Fuel Injection (Cont.)

3) Loosen rod lock nut and adjust rod length until drive lever is properly positioned between marks. Tighten lock nut and install capsule rod to drive lever.

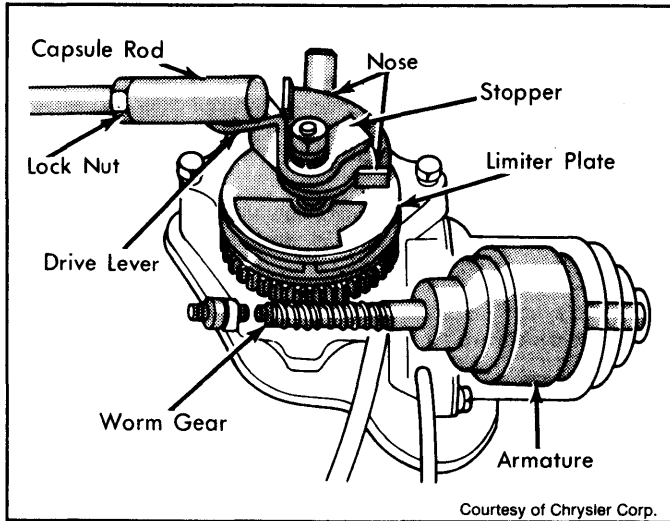

Fig. 14: Adjusting Capsule Rod Length & Drive Lever Position

INJECTION NOZZLE ADJUSTMENT

1) Install nozzle holder and tip on nozzle tester. See Fig. 15. Operate tester handle several times to bleed nozzle and line.

2) As tester lever is operated, pressure should rise steadily. At some point pressure will reach a maximum and drop off suddenly. The maximum pressure reading is the injection pressure.

3) Standard injection pressure is between 1700 psi (120 kg/cm²) and 1850 psi (130 kg/cm²). If pressure does not meet specifications, it must be adjusted by installing or removing shims between nozzle body and pressure spring.

4) Install shim pack of required thickness to ensure injection pressure is within specifications. Reassemble nozzle holder and nozzle assembly.

NOTE: Changing thickness of shim pack by .004" (01. mm) varies injection pressure by 142 psi (10 kg/cm²). Shims are available in thicknesses from .040" (1.00 mm) to .077" (1.96 mm) at .002" (.05 mm) intervals.

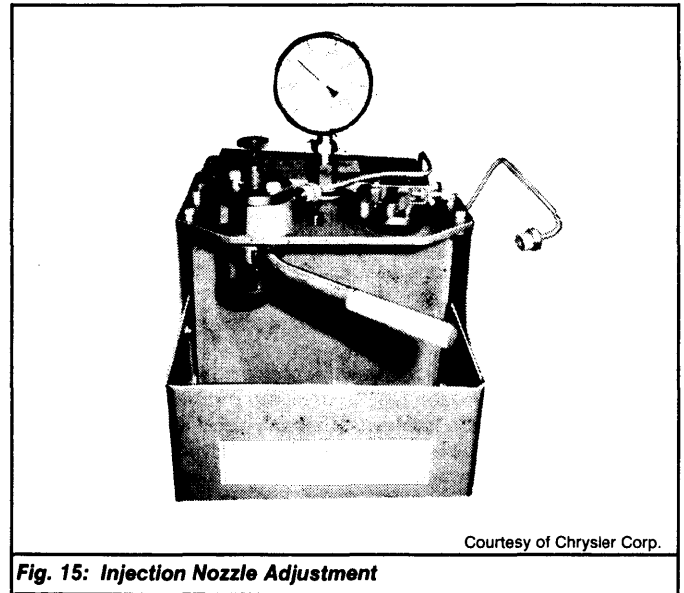

Fig. 15: Injection Nozzle Adjustment