

1975-79 FUEL SYSTEMS

Rochester 4MC & 4MV 4-Barrel Carburetors

1975-78 General Motors

CARBURETOR APPLICATION

NOTE: SERIES IDENTIFICATION: The vehicle series numbers used in this article have been abbreviated for common reference to both Chevrolet and GMC models. Chevrolet models use numerical designations as listed; GMC models are identified as follows: 10 = 1500; 20 = 2500; 30 = 3500.

1975 GENERAL MOTORS CORP.

Application	Rochester Carb. No. Man. Trans.	Rochester Carb. No. Auto. Trans.
C10-30, K20-30		
350" V8		
Federal	7045213	7045213
California	7045583	7045583
G20-30		
350" V8		
Federal	7045214	7045214
California	7045584	7045584
P20-30		
350" V8		
Federal	7045216	7045516
California	7045586	7045586
P30 Motor Home		
350" V8		
Federal		7045215
California		7045585
G20-30		
400" V8		
Federal		7045225
California		7045588
K10-20		
400" V8		
Federal	7045229	7045229
California	7045589	7045589
C10-30 & P30 Motor Home		
454" V8		
Federal	7045212	7045212
P30		
454" V8		
Federal		7045217
GMC Motor Home		
455" V8 ¹		
Federal		7045254
California		7045554

¹ - Model 4MC Rochester 4-Barrel. All others are model 4MV.

1976 GENERAL MOTORS CORP.

Application	Rochester Carb. No. Man. Trans.	Rochester Carb. No. Auto. Trans.
C10-30, K20-30		
350" V8		
Federal	7045213	7045213
California	7045583	7045583
G20-30		
350" V8		
Federal	7045214	7045214
California	7045584	7045584
P20-30		
350" V8		
Federal	7045216	7045516
California	7045586	7045586

1976 GENERAL MOTORS CORP. (Cont.)

Application	Rochester Carb. No. Man. Trans.	Rochester Carb. No. Auto. Trans.
P30-Motor Home		
350" V8		
Federal		7045215
California		7045585
G20-30		
400" V8		
Federal		7045225
California		7045589
K10-20		
400" V8		
Federal		7045229
California		7045588
C10-30 & P30 Motor Home		
454" V8		
Federal	7045212	7045212
P30		
454" V8		
Federal		7045217
GMC Motor Home		
455" V8 ¹		
Federal		7045254
California		7045554

¹ - Model 4MC Rochester 4-Barrel. All others are model 4MV.

1977 GENERAL MOTORS CORP.

Application	Rochester Carb. No. Man. Trans.	Rochester Carb. No. Auto. Trans.
C10-30, K20-30		
350" V8		
Federal	17057213	17057213
California	7045583	7045583
G20-30		
350" V8		
Federal	17057213	17057213
California	17057514	17057514
P20-30		
350" V8		
Federal	17057216	17057516
California	7045586	7045586
P30-Motor Home		
350" V8		
Federal		17057215
California		7045585
G20-30, K10-30		
400" V8		
Federal		17057229
California		17057525, 529
C10-30		
454" V8		
Federal	17056212	17056212
P30		
454" V8		
Federal		17056217
GMC Motor Home		
455" V8 ¹		
Federal		7045254
California		7045554

¹ - Model 4MC Rochester 4-Barrel. All others are model 4MV.

1975-79 FUEL SYSTEMS

Rochester 4MC & 4MV 4-Barrel Carburetors (Cont.)

1978 GENERAL MOTORS CORP.

Application	Rochester Carb. No. Man. Trans.	Rochester Carb. No. Auto. Trans.
350" V8		
Federal	17058213	17058213
		17058215
California	17058513	17058513
	17058514	17058514
		17058515
400" V8		
Federal		17058229
California		17058525
		17058529
454" V8		
Federal	17058212	17058212
California	17058212	17058212

NOTE: Some 1978 models may use Rochester M4MC carburetors. See appropriate FUEL SYSTEMS article for service procedures.

CARBURETOR IDENTIFICATION

The Rochester 4MC and 4MV carburetor number is stamped on a vertical section of the float bowl, near the secondary throttle. If float bowl is replaced, follow manufacturer's instructions contained in service package to ensure part number is transferred to new float bowl.

DESCRIPTION

The 4MC and 4MV carburetors are of a 2-stage downdraft design. The primary side has a triple venturi system. The secondary side is composed of 2 large bores using the air valve principle in which fuel is metered in direct proportion to amount of air passing through the secondary bores. A baffle is attached to the secondary side of the air horn above the main well bleed tubes to deflect incoming air to improve secondary nozzle operation on heavy acceleration. Model 4MC carburetors use a bowl-mounted choke housing with thermostatic control assembly. Model 4MV carburetors use an intake manifold mounted thermostatic choke control assembly with a connecting rod to carburetor.

ADJUSTMENTS

HOT (SLOW) IDLE RPM

See appropriate article in TUNE-UP PROCEDURES section.

IDLE MIXTURE

See appropriate article in TUNE-UP PROCEDURES section.

FLOAT LEVEL

1) Remove air horn. Remove gasket from main body casting. Hold float retainer firmly in place. See Fig. 1. Apply light finger pressure to push float gently against needle. Measure distance with "T" scale from top of casting to top of float. Gauging point should be $\frac{3}{16}$ " back from end of float at toe.

2) If adjustment is needed, remove float from main body of carburetor. Bend float arm up or down. Install float and recheck float level. Be sure to check float alignment after adjusting operation. Install new gasket and reinstall air horn.

ACCELERATOR PUMP ROD

Model 4MC - 1) Hold choke wide open and open throttle. Release throttle and ensure fast idle cam is released. Adjust idle speed screw to obtain a .030" clearance at primary throttle valve bore.

2) Ensure pump rod is in inner hole of pump actuating rod. Measure from choke valve wall to top of pump stem. If measurement is not to specification, adjust by bending pump rod. See Fig. 2.

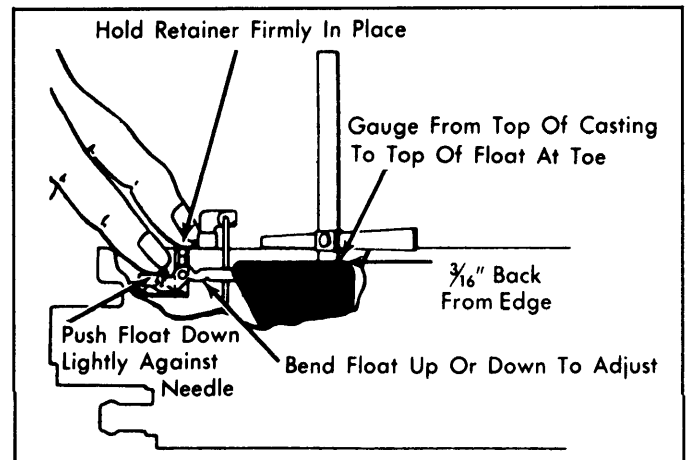

Courtesy of General Motors Corp.

Fig. 1: Adjusting Float Level

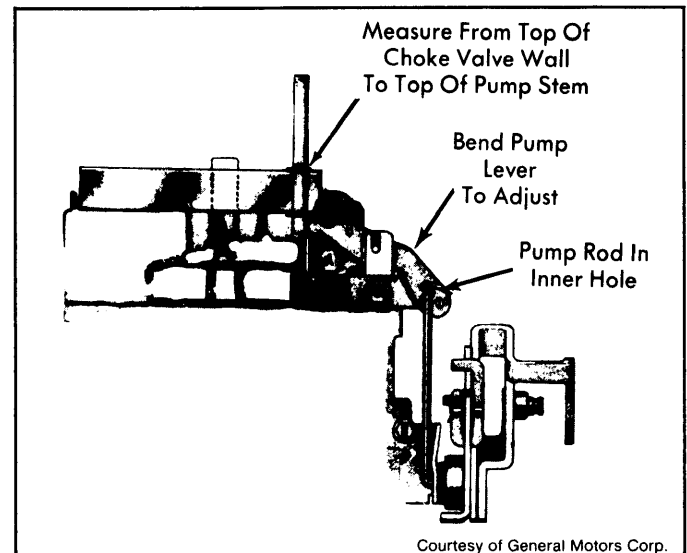

Courtesy of General Motors Corp.

Fig. 2: Adjusting Model 4MC Accelerator Pump

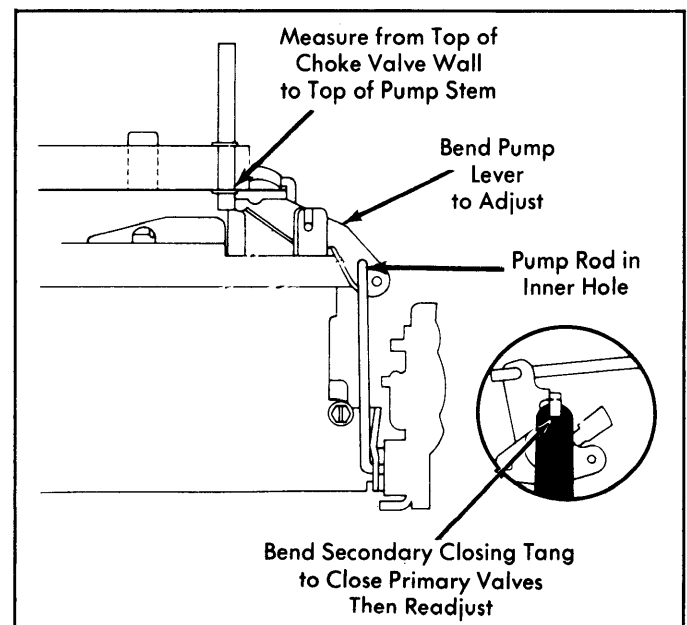

Courtesy of General Motors Corp.

Fig. 3: Adjusting Model 4MV Accelerator Pump

1975-79 FUEL SYSTEMS

Rochester 4MC & 4MV 4-Barrel Carburetors (Cont.)

Model 4MV - 1) Close throttle valves completely. Make sure fast idle cam follower is off fast idle cam steps. Bend secondary throttle closing tang (if necessary) to make sure primary throttle valves are fully closed. Readjust after accelerator pump adjustment. See Fig. 3. 2) Make sure accelerator pump rod is in specified hole (inner or outer) in accelerator pump lever. Using a "T" scale, measure specified distance from top of choke valve wall (next to vent stack) to top of pump stem. To adjust, bend accelerator pump lever. See Fig. 3.

CHOKE COIL LEVER

Model 4MC - 1) Loosen 3 screws retaining thermostatic cover and coil assembly and remove cover from housing. Press upward on thermostatic coil tang (counterclockwise) until choke valve is closed. See Fig. 4.

2) Make sure choke rod is in bottom of slot in choke lever. Insert a drill or pin gauge of specified size into hole in choke housing casting.

3) Lower edge of lever in choke housing should just touch drill or pin gauge. Bend choke rod at point shown to adjust. Install choke coil and cover. Adjust automatic choke.

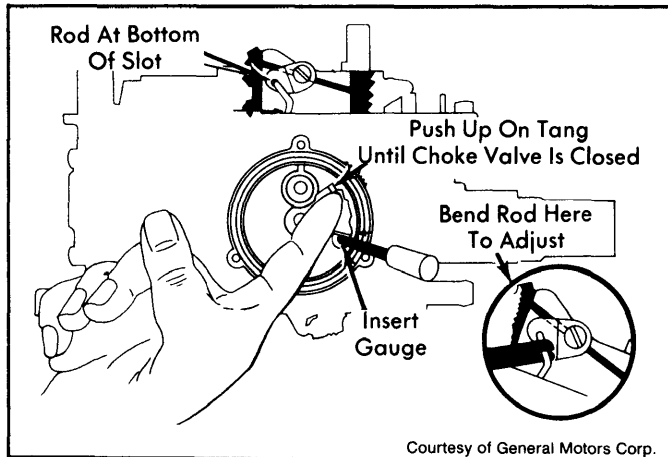

Courtesy of General Motors Corp.

Fig. 4: Adjusting Model 4MC Choke Coil Lever

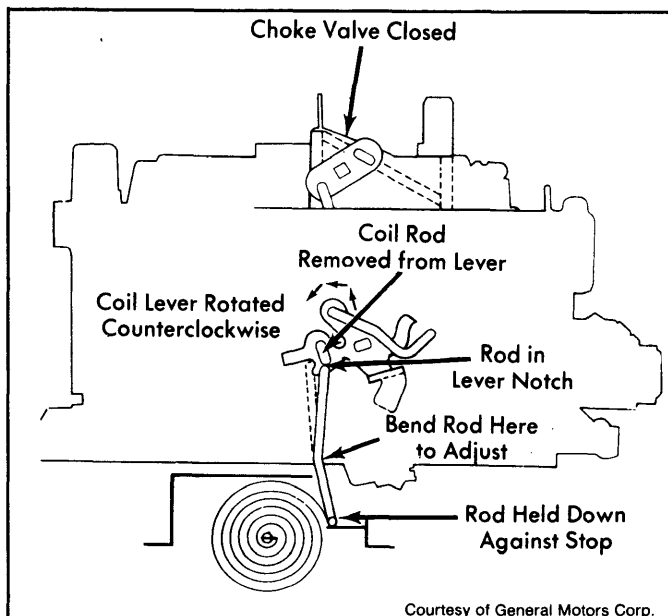

Courtesy of General Motors Corp.

Fig. 5: Adjusting Model 4MV Choke Coil Rod

CHOKE COIL ROD

Model 4MV - Remove thermostatic coil rod from choke lever. Rotate lever counterclockwise until choke valve is completely closed. Hold choke rod down against stop. Rod should fit in notch in choke coil lever. Bend rod (if necessary) to adjust. See Fig. 5.

FAST IDLE

Model 4MC - Place fast idle speed cam follower on second step of fast idle cam, next to highest step. Push up on choke coil lever. Insert specified gauge between lower edge of choke valve and air horn wall. If clearance is not to specification, bend tang to adjust. See Fig. 6.

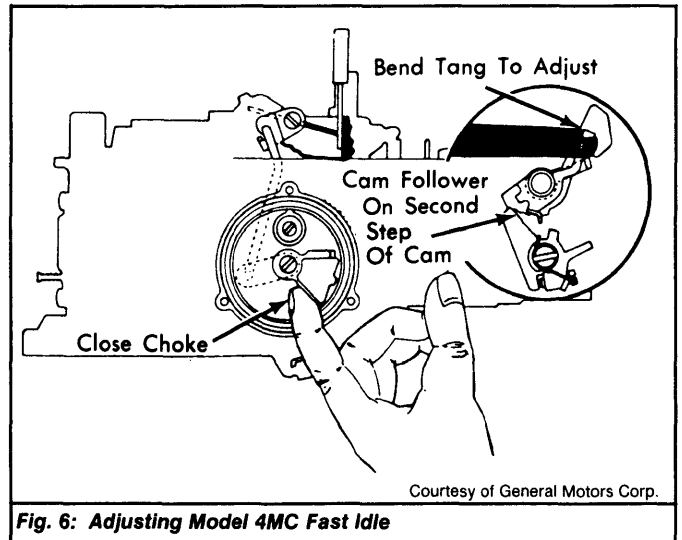

Courtesy of General Motors Corp.

Fig. 6: Adjusting Model 4MC Fast Idle

Model 4MV - Place fast idle speed cam follower on second step of fast idle cam, next to highest step. Push up on vacuum break lever to close choke valve as far as possible. Insert specified gauge between upper edge of choke valve and air horn wall. If clearance is not to specification, bend choke rod to adjust. See Fig. 7.

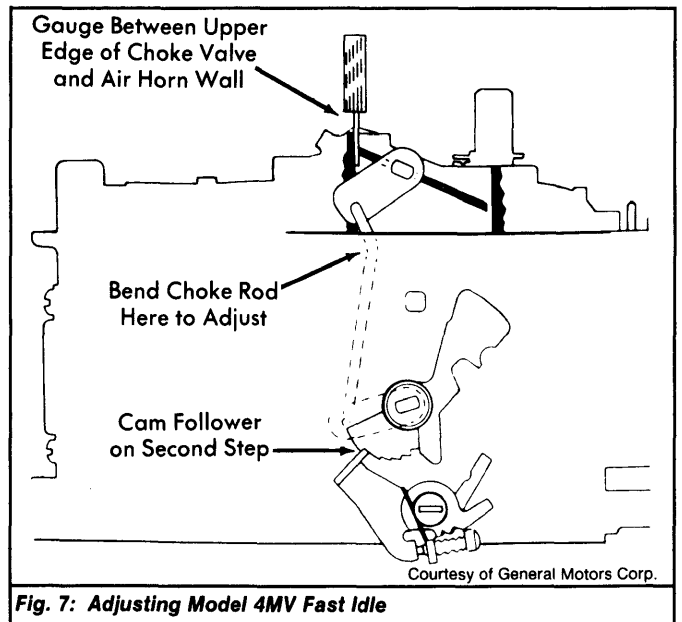

Courtesy of General Motors Corp.

Fig. 7: Adjusting Model 4MV Fast Idle

CHOKE UNLOADER

Model 4MC - With primary throttle valves wide open, insert a specified gauge between lower edge of choke valve and air horn wall. If clearance is not to specification, bend tang to adjust. See Fig. 8.

1975-79 FUEL SYSTEMS

Rochester 4MC & 4MV 4-Barrel Carburetors (Cont.)

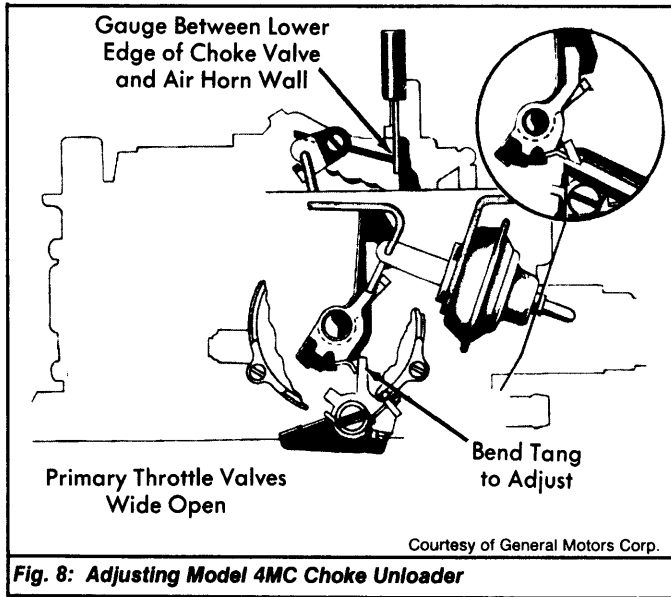

Fig. 8: Adjusting Model 4MC Choke Unloader

Model 4MV – Lightly push up on vacuum lever to close choke valve and hold in position with a rubber band. With primary throttle valves wide open, insert a specified gauge between upper edge of choke valve and air horn wall. If clearance is not to specification, bend tang to adjust. See Fig. 9.

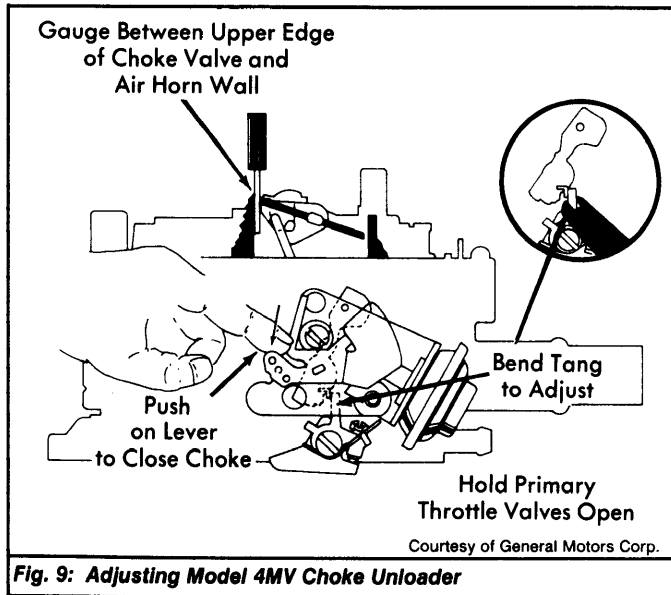

Fig. 9: Adjusting Model 4MV Choke Unloader

VACUUM BREAK

Model 4MC – 1) Place fast idle cam follower on highest step of fast idle cam. Using an outside vacuum source, seat choke vacuum break diaphragm. Plug purge bleed hole (if equipped) with masking tape. Hole is found in end of diaphragm. See Fig. 10.

2) With choke coil cover removed, push up on choke lever until tang on outside lever contacts vacuum break rod. Insert a specified gauge between lower edge of choke valve and air horn wall. If clearance is not to specification, bend lower end of rod to adjust.

Model 4MV – 1) Using an outside vacuum source, seat vacuum break diaphragm. Open primary throttle valves enough so cam follower clears fast idle cam.

2) Gently rotate choke coil lever counterclockwise until end of rod is in end of lever slot. See Fig. 11. Insert pin gauge or drill bit of specified size between air horn wall and upper edge of choke wall. Bend rod if adjustment is needed.

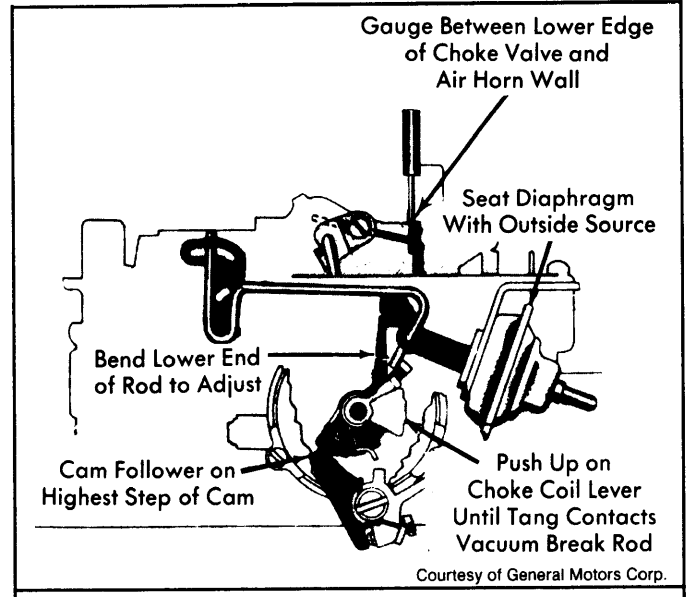

Fig. 10: Adjusting Model 4MC Vacuum Break

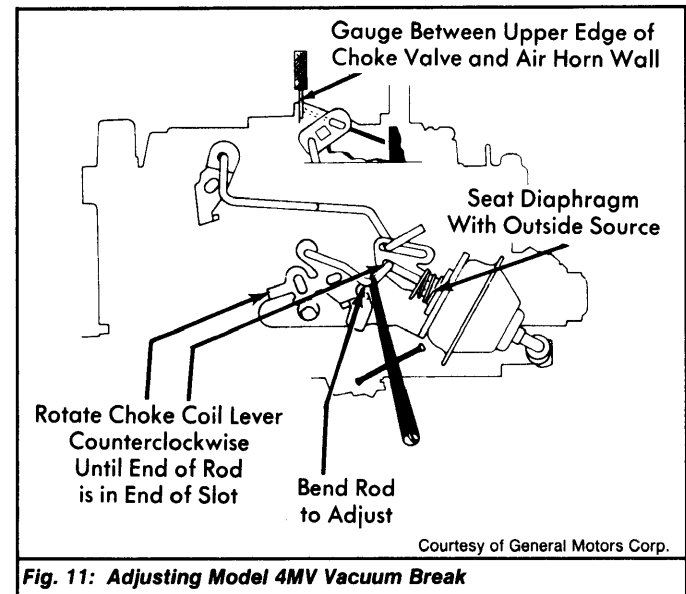

Fig. 11: Adjusting Model 4MV Vacuum Break

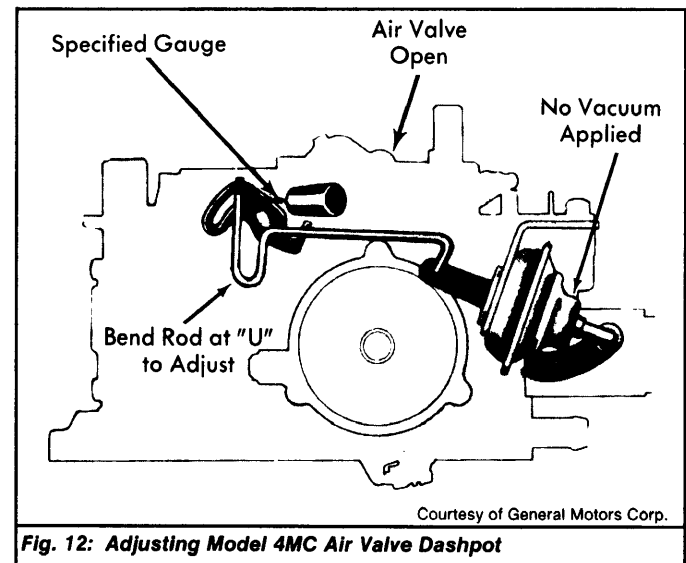

Fig. 12: Adjusting Model 4MC Air Valve Dashpot

1975-79 FUEL SYSTEMS

Rochester 4MC & 4MV 4-Barrel Carburetors (Cont.)

AIR VALVE DASHPOT

Model 4MC - With no vacuum applied to dashpot, open secondary air valve wide open. Insert a specified gauge in linkage slot. See Fig. 12. If clearance is not to specification, bend rod at "U" to adjust.

Model 4MV - Using an outside vacuum source, fully seat dashpot. Fully close secondary air valve. Insert a specified gauge between slot in end of vacuum break plunger and air valve rod. See Fig. 13. If clearance is not to specification, bend rod to adjust.

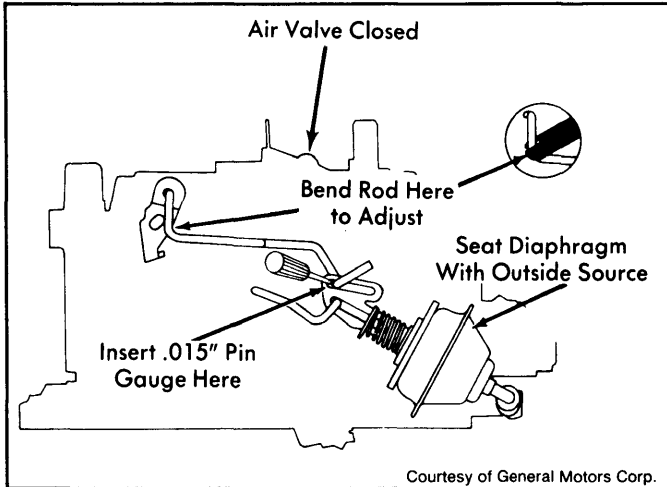

Fig. 13: Adjusting Model 4MV Air Valve Dashpot

AIR VALVE LOCK-OUT

Model 4MC - Push down on tail of fast idle cam and hold air valve open slightly. Insert a specified gauge between front edge of air valve and tang. See Fig. 14. Specified clearance is .035". If clearance is not to specification, bend tang to adjust.

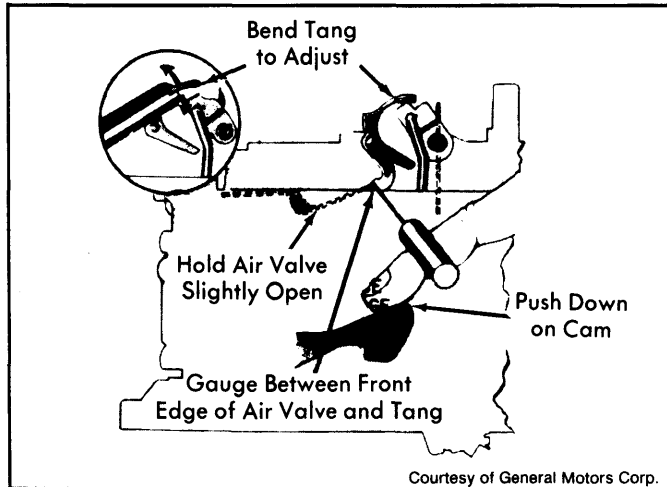

Fig. 14: Adjusting Model 4MC Air Valve Lock-Out

SECONDARY VALVE LOCK-OUT

Model 4MV (Lock-Out Lever Clearance) - With choke valve and secondary throttle valves held closed, clearance between lock-out pin and lock-out lever should be .015". If clearance is not to specification, bend lock-out pin to adjust.

Model 4MV (Opening Clearance) - Push down on tail of fast idle cam and hold choke valve wide open. With secondary throttle valves wide open, clearance between lock-out pin and toe of lock-out lever should be .015". To adjust, file off end of lock-out pin to obtain specified clearance.

SECONDARY VALVE CLOSING

Model 4MV - 1) Ensure idle speed is correct. Hold choke valve wide open. Fast idle cam follower must be off fast idle cam. Primary throttle lever must be against actuator tang. See Fig. 15.

2) Insert a .020" gauge between secondary throttle pick-up lever and secondary actuating rod. If adjustment is needed, bend secondary closing tang.

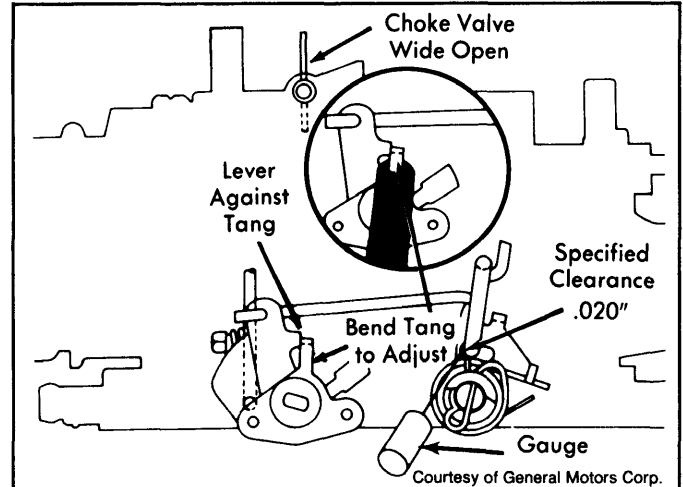

Fig. 15: Adjusting Model 4MC Secondary Closing

SECONDARY VALVE OPENING

Model 4MC - Open primary throttle valves until link just contacts tang on secondary lever. With link against tang, there should be .070" clearance between link and tang on model 4MC carburetor (in center of slot on model 4MV carburetor). See Fig. 16. Bend tang to adjust.

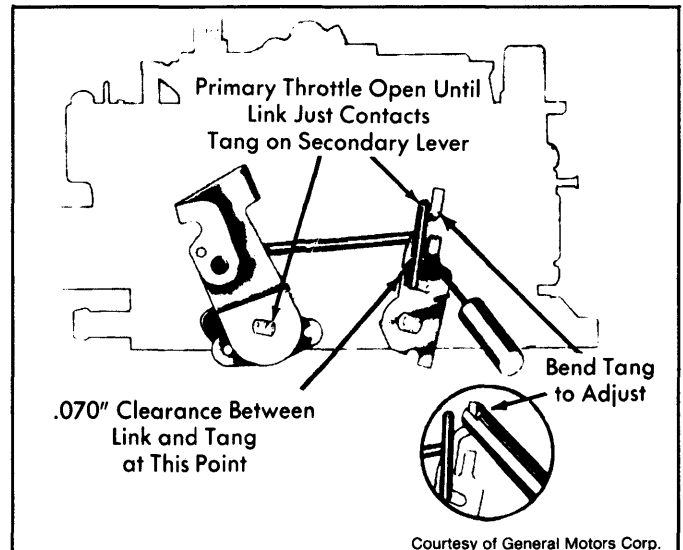

Fig. 16: Adjusting Model 4MC Secondary Opening

AIR VALVE SPRING WIND-UP

1) Remove vacuum break diaphragm and air valve dashpot rod. Using an Allen wrench, loosen lock screw. Turn tension adjusting screw counterclockwise until air valve partially opens. See Fig. 17.

2) Hold air valve closed. Turn tension adjusting screw clockwise specified turns after spring contacts pin. Tighten lock screw and reinstall vacuum break diaphragm.

1975-79 FUEL SYSTEMS

Rochester 4MC & 4MV 4-Barrel Carburetors (Cont.)

2-109

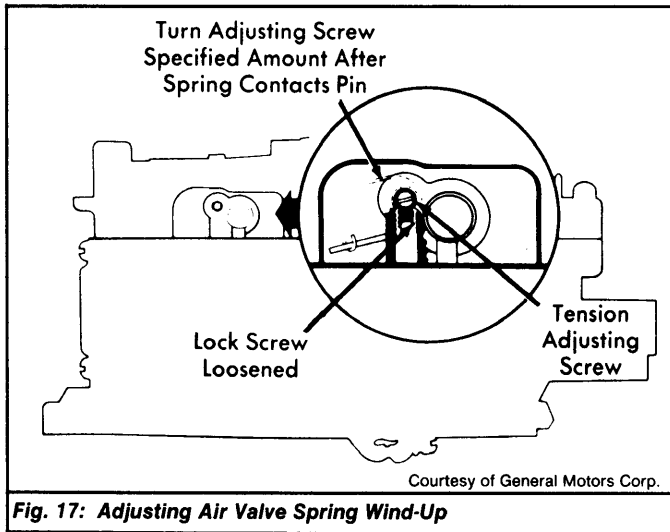

Fig. 17: Adjusting Air Valve Spring Wind-Up

OVERHAUL

CARBURETOR

Removal (Air Horn) – 1) Remove upper choke lever from end of choke shaft by removing retaining screw. Then rotate upper choke lever to remove choke rod from slot in lever. Remove rod by holding lower lever outward with small screwdriver and twisting rod counterclockwise.

2) Remove vacuum hose from front vacuum break unit. Remove secondary metering rods by removing the small screw in top of metering rod hanger. Lift upward on metering rod hanger until secondary metering rods are completely out of air horn. Metering rods may be disassembled from hanger by rotating ends out of holes in end of hanger.

3) Remove idle vent valve assembly. Drive small roll pin (pump lever pivot pin) inward until pump lever can be removed from air horn, then remove pump lever from pump rod. Remove 9 air horn-to-bowl attaching screws: 2 next to venturi, 5 short screws, and 2 countersunk screws. Remove secondary air baffle deflector, if equipped, from beneath 2 center air horn screws. Remove air horn from float bowl (using care not to bend small protruding tubes) by lifting straight up. Air horn gasket should remain on float bowl.

Disassembly (Air Horn) – 1) Remove vacuum break from bracket. Remove diaphragm from air valve dashpot rod and remove dashpot rod from air valve lever.

2) If necessary, remove staking on both choke valve attaching screws. Remove choke shaft and choke valve from air horn.

NOTE: Air valves (secondary) and air valve shaft should not be removed. However, if it is necessary to replace air valve closing spring or center plastic eccentric cam, a repair kit is available.

Disassembly (Float Bowl) – 1) Remove air horn gasket by lifting out of dowel locating pins and lifting tab of gasket from beneath power piston hanger, being careful not to distort springs holding main metering rods.

2) Remove pump plunger from pump well. Remove pump return spring from pump well. Remove power piston and metering rods by depressing piston stem and allowing it to snap free. Do not remove power piston by using pliers on metering rod hanger. Remove power piston spring from well.

3) Remove metering rods from power piston by disconnecting tension spring from top of each rod. Then, rotate rod to remove from hanger. Use care when disassembling rods to prevent distortion of tension spring and metering rods. Carefully note the position of tension spring for reassembly. Remove plastic filler block over float valve.

4) Remove float assembly and float needle by pulling up on retaining pin. Remove float needle seat and gasket. Remove primary main metering jets. Remove pump discharge check ball retainer and check ball.

5) Remove vacuum break rod by holding down on fast idle cam (hot idle position); move end of vacuum break rod away from float bowl, then disengage rod from hole in intermediate choke lever.

Disassembly (Choke) – 1) On 4MC model carburetors, remove 3 attaching screws and retainers from choke cover and coil assembly, then pull straight outward and remove cover and coil assembly from choke housing.

2) Remove choke cover gasket. It is not necessary to remove baffle plate from beneath thermostatic coil. Distortion of thermostatic coil may result if forced off center retaining post on choke cover.

3) Remove choke housing assembly from float bowl by removing retaining screw and washer inside choke housing. Complete choke assembly can be removed from float bowl by sliding outward.

4) On all models, remove secondary throttle valve lock-out lever from float bowl and lower choke lever from inside float bowl cavity (invert bowl to remove). Remove plastic tube seal from choke housing.

5) To disassemble intermediate choke shaft from choke housing, remove coil lever retaining screw at end of shaft inside choke housing. Remove thermostatic coil lever from flats on intermediate choke shaft. Remove intermediate choke shaft from choke housing by sliding outward. Fast idle cam can now be removed from intermediate choke shaft.

6) Remove cup seal from inside choke housing shaft hole if housing is to be immersed in carburetor cleaner. Also, remove cup seal from float bowl plastic insert for bowl cleaning purposes. DO NOT attempt to remove plastic insert.

Disassembly (Throttle Body) – Remove accelerator pump rod from throttle lever. Remove idle mixture screws and springs.

Cleaning & Inspection – Use a regular carburetor cleaning solution. Soak components long enough to thoroughly clean all surfaces and passages of foreign matter. Remove any residue after cleaning by rinsing components in a suitable solvent. Do not soak any components containing rubber, leather or plastic. Blow out all passages with dry compressed air.

Reassembly (Throttle Body) – 1) Install idle mixture screws and springs. Lightly seat screws, then back out 2 turns as a preliminary adjustment.

2) Install accelerator pump rod in throttle lever. Align tang on rod with slot in lever. End of rod should point outward toward throttle lever.

Reassembly (Choke Housing) – 1) Install new cup seal into insert on side of float bowls for intermediate choke shaft. Lip of cup seal faces outward. Install secondary throttle valve lock-out lever on boss on float bowl with recess in hole in lever facing carburetor bowl. Install intermediate choke shaft (steps on fast idle cam face downward).

2) Carefully install fast idle cam and intermediate choke shaft assembly in choke housing. Install thermostatic coil lever onto flats on intermediate choke shaft. Inside thermostatic choke coil lever is properly aligned when both inside and outside levers face toward fuel inlet. Install inside lever retaining screw into end of intermediate choke shaft and tighten.

3) Install lower choke rod lever into cavity in float bowl. Install choke housing-to-bowl sliding intermediate choke shaft into lower choke lever. Install choke housing retaining screws and washers. Do not install choke cover and coil assembly until choke coil lever is properly adjusted.

NOTE: The intermediate choke shaft lever and fast idle cam are in correct relationship when tang on lever is beneath fast idle cam.

1975-79 FUEL SYSTEMS

Rochester 4MC & 4MV 4-Barrel Carburetors (Cont.)

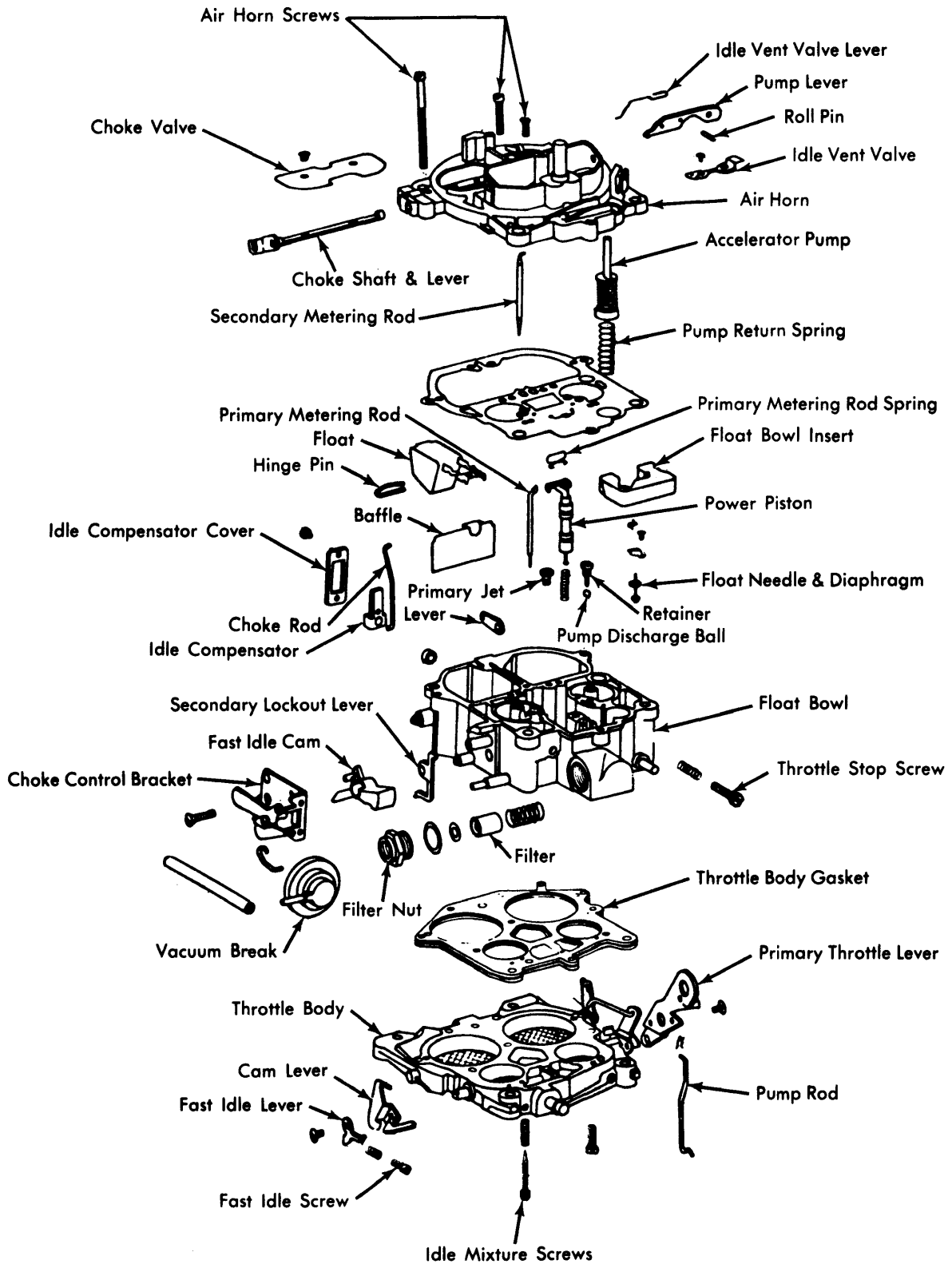

Courtesy of General Motors Corp.

Fig. 18: Exploded View of Rochester Model 4MV 4-Barrel Carburetor

1975-79 FUEL SYSTEMS

Rochester 4MC & 4MV 4-Barrel Carburetors (Cont.)

2-111

Reassembly (Float Bowl) - 1) Install new throttle body gasket over 2 locating dowels on bowl. Install throttle body, making certain throttle body is properly located over dowels on float bowl, then install 2 throttle body-to-bowl screws and tighten.

2) Place carburetor on holding fixture. Install fuel inlet filter spring, filter, new gasket, inlet nut and tighten inlet nut to 18 ft. lbs. Install air baffle in secondary side of float bowl with notches toward top. Top edge of baffle must be flush with bowl casting.

3) If removed, install baffle in pump well slot. Install accelerator pump discharge check ball and retainer in passage next to pump well. Tighten retainer. Install primary main metering jets.

4) Install new needle seat assembly with gasket. To facilitate adjustment, bend float arm upward at notch in arm before assembly. Install float by sliding float lever under pull-clip from front to back. With float lever in pull-clip, hold float assembly at toe and install retaining pin.

5) Adjust float level. Install plastic filler block over float needle, pressing downward until properly seated. Install power piston spring in power piston well. If main metering rods were removed from hanger, reinstall, making sure tension spring is connected to top of each rod.

6) Install power piston assembly in well with metering rods properly positioned in metering jets. Press down firmly on plastic power piston retainer to make sure retainer is seated in recess in bowl and top is flush with top of bowl casting. If necessary, tap retainer lightly into place.

7) Install pump return spring in pump well. Install air horn gasket by carefully sliding tab of gasket around main metering rods and beneath power piston hanger. Position gasket over 2 dowel pins on float bowl.

8) Carefully lift one corner of air horn gasket and install pump plunger in pump well by pushing plunger to bottom of well against return spring tension. While holding in this position, align pump plunger stem with hole in gasket and press in place.

Reassembly (Air Horn) - 1) If removed, install choke shaft, choke valve, and 2 attaching screws. Tighten screws securely and stake lightly into place. Check choke valve for freedom of movement and proper alignment before staking screws in place.

2) Holding down on air horn gasket at pump plunger location, carefully lower air horn assembly onto float bowl, making sure that bleed tubes, accelerating well tubes, pullover enrichment tubes (if used), and pump plunger stem are positioned properly through holes in air horn gasket.

NOTE: DO NOT force air horn assembly onto bowl, but rather lower lightly into place.

3) Install 2 long air horn screws, 5 short screws, and 2 countersunk screws into primary venturi area. If used, install secondary air baffle beneath 2 center air horn screws. All air horn screws must be tightened evenly and securely. See Fig. 19.

4) Install vacuum break diaphragm rod into slot in lever on end of air valve shaft. Then, install other end of rod into hole in front vacuum break diaphragm plunger. Install front vacuum break control and bracket assembly to air horn, using 2 retaining screws through bracket. Tighten screws securely. Do not attach vacuum break hose until vacuum break adjustment is complete.

5) Connect upper end of pump rod-to-pump lever by placing rod in specified hole in lever. Align hole in pump lever with hole in air horn casting. Using small screwdriver, push pump lever roll pin back through casting until end of pin is flush with casting bosses in air horn.

6) Install 2 secondary metering rods into secondary metering rod hanger (upper end of rods point toward each other). Install secondary metering rod holder, with rods onto air valve cam follower. Install retaining screw and tighten securely. Work air valves up and down several times to ensure they are free in all positions.

7) Connect choke rod into lower choke lever inside bowl cavity. Install choke rod into slot in upper choke lever and retain choke lever to end of choke shaft with attaching screw. Make sure that flats on end of choke shaft align with flats in choke lever. Vacuum break unit, fast idle cam (choke rod), and inside thermostatic choke coil lever must be adjusted properly before installing choke thermostatic coil and cover assembly and gasket.

8) After above adjustments are complete, the thermostatic coil and cover assembly and gasket should be installed and cover assembly rotated until choke valve just closes. Index cover should be adjusted. Install 3 choke cover retainers and screws and tighten securely.

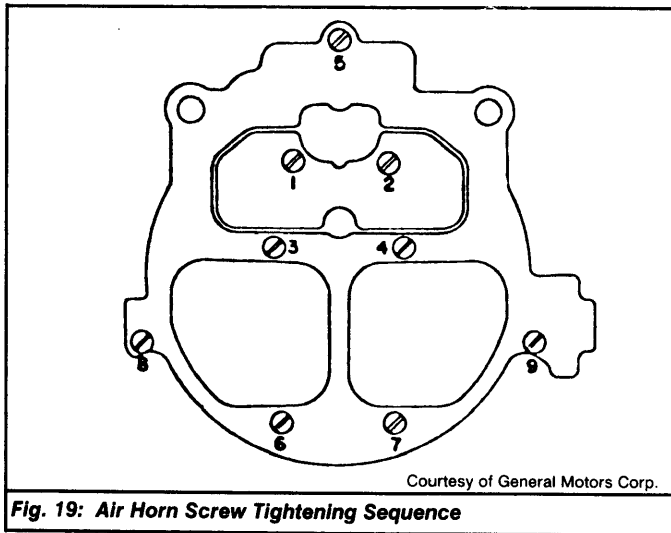

Fig. 19: Air Horn Screw Tightening Sequence

Courtesy of General Motors Corp.

1975-79 FUEL SYSTEMS

Rochester 4MC & 4MV 4-Barrel Carburetors (Cont.)

1975 CARBURETOR ADJUSTMENT SPECIFICATIONS										
① Rochester Carb. No.	Unloader	Pump Rod	Pump Float Setting	Rod Location	Air Choke Rod	Rear Valve Dashpot	Front Vac. Break	Air Vac. Break	Choke Valve Windup	Coil Lever
Model 4MV										
5212	.450"	.275"	3/8"	Inner	.430"	.015"225"	7/16"
5213	.450"	.275"	11/32"	Inner	.430"	.015"210"	7/8"
5214	.450"	.275"	11/32"	Inner	.430"	.015"215"	7/8"
5215	.450"	.275"	11/32"	Inner	.430"	.015"215"	7/8"
5216	.450"	.275"	11/32"	Inner	.430"	.015"210"	7/8"
5217	.450"	.275"	3/8"	Inner	.430"	.015"225"	7/16"
5225	.450"	.275"	11/32"	Inner	.430"	.015"200"	3/4"
5229	.450"	.275"	15/32"	Inner	.430"	.015"200"	3/4"
5583	.450"	.275"	11/32"	Inner	.430"	.015"230"	7/8"
5584	.450"	.275"	11/32"	Inner	.430"	.015"230"	7/8"
5585	.450"	.275"	11/32"	Inner	.430"	.015"230"	7/8"
5586	.450"	.275"	11/32"	Inner	.430"	.015"230"	7/8"
5588	.450"	.275"	11/32"	Inner	.430"	.015"230"	3/4"
5589	.450"	.275"	11/32"	Inner	.430"	.015"230"	3/4"
Model 4MC										
5254	.300"	5/16"	1/4"	Inner	.230"	.030"215"	3/4"	.120"
5554	.300"	5/16"	1/4"	Inner	.230"	.030"215"	3/4"	.120"

① — Basic number prefix is 704.

1976 CARBURETOR ADJUSTMENT SPECIFICATIONS										
Rochester Carb. No.	Idle Speed (Engine RPM)		Float Setting	Pump Rod Setting	Choke Rod Setting	Choke Unloader Setting	Air Valve Dashpot	Vacuum Break Setting	Air Valve Windup ②	Choke Setting
	Hot	Fast								
4MV										
7045213	600	1600	11/32"	9/32"	.290"	.295"	.015"	.145"	7/8"	①
7045214	600	1600	11/32"	9/32"	.290"	.295"	.015"	.145"	7/8"	①
7045215	600	1600	11/32"	9/32"	.290"	.295"	.015"	.145"	7/8"	①
7045216	600	1600	11/32"	9/32"	.290"	.295"	.015"	.145"	7/8"	①
7045225	700	1600	11/32"	9/32"	.290"	.295"	.015"	.138"	3/4"	①
7045229	700	1600	11/32"	9/32"	.290"	.295"	.015"	.138"	3/4"	①
7045583	700	1600	11/32"	9/32"	.290"	.295"	.015"	.155"	7/8"	①
7045584	700	1600	11/32"	9/32"	.290"	.295"	.015"	.155"	7/8"	①
7045585	700	1600	11/32"	9/32"	.290"	.295"	.015"	.155"	7/8"	①
7045586	700	1600	11/32"	9/32"	.290"	.295"	.015"	.155"	7/8"	①
7045588	700	1600	11/32"	9/32"	.290"	.295"	.015"	.155"	3/4"	①
7045589	700	1600	11/32"	9/32"	.290"	.295"	.015"	.155"	3/4"	①
17056212	600	1600	3/8"	"	.290"	.295"	.015"	.155"	7/16"	①
17056217	600	1600	3/8"	"	.290"	.295"	.015"	.155"	7/16"	①
4MC										
7045254	600	1100	1/4"	3/8"	.230"	.300"	.050"	.275"	3/4"	Index
7045554	600	1100	1/4"	3/8"	.230"	.300"	.050"	.275"	3/4"	Index

① — See Choke Coil Rod Adjustment in this Section.

② — Amount of turn required on tension adjusting screw.

1975-79 FUEL SYSTEMS

2-113

Rochester 4MC & 4MV 4-Barrel Carburetors (Cont.)

1977 CARBURETOR ADJUSTMENT SPECIFICATIONS										
Rochester Carb. No.	Idle Speed (Engine RPM)		Float Setting	Pump Rod Setting	Choke Rod Setting	Choke Unloader Setting	Air Valve Dashpot	Vacuum Break Setting	Air [Ⓛ] Valve Windup	Choke Setting
	Hot	Fast								
4MC										
7045254	600	1100	1/4"	3/8"	.230"	.300"	.050"	.275"	3/4	Index
7045554	600	1100	1/4"	3/8"	.230"	.300"	.050"	.275"	3/4	Index
4MV										
7045583	700	1600 [Ⓛ]	1 1/32"	3/32"	.290"	.295"	.015"	.120"	7/8	Ⓛ
7045585	700	1600 [Ⓛ]	1 1/32"	3/32"	.290"	.295"	.015"	.120"	7/8	Ⓛ
7045586	700	1600 [Ⓛ]	1 1/32"	3/32"	.290"	.295"	.015"	.120"	7/8	Ⓛ
17056212	700	1700 [Ⓛ]	3/8"	3/32"	.290"	.295"	.015"	.120"	7/16	Ⓛ
17056217	700	1700 [Ⓛ]	3/8"	3/32"	.290"	.295"	.015"	.120"	7/16	Ⓛ
17057213	700	1600 [Ⓛ]	1 1/32"	3/32"	.220"	.205"	.015"	.115"	7/8	Ⓛ
17057215	700	1600 [Ⓛ]	1 1/32"	3/32"	.220"	.205"	.015"	.115"	7/8	Ⓛ
17057216	700	1600 [Ⓛ]	1 1/32"	3/32"	.220"	.205"	.015"	.115"	7/8	Ⓛ
17057229	700	1600 [Ⓛ]	1 1/32"	3/32"	.220"	.205"	.015"	.110"	7/8	Ⓛ
17057514	700	1600 [Ⓛ]	1 1/32"	3/32"	.220"	.225"	.015"	.120"	7/8	Ⓛ
17057525	700	1600 [Ⓛ]	1 1/32"	3/32"	.220"	.225"	.015"	.120"	3/4	Ⓛ
17057529	700	1600 [Ⓛ]	1 1/32"	3/32"	.220"	.205"	.015"	.110"	7/8	Ⓛ

- Ⓛ — Amount of turn on tension adj. screw
- Ⓛ — See Choke Coil Rod Adjustment in this article.
- Ⓛ — Transmission in NEUTRAL

1978 CARBURETOR ADJUSTMENT SPECIFICATIONS										
Rochester Carb. No.	Idle Speed (Engine RPM)		Float Setting	Pump Rod Setting	Choke Rod Setting	Choke Unloader Setting	Air Valve Dashpot	Vacuum Break Setting	Air Valve Windup	Choke Setting
	Hot	Fast								
17058212	Ⓛ	Ⓛ	.438"	.281"	.217"	.225"	.015"	.120"	.875"	Ⓛ
17058213	Ⓛ	Ⓛ	.469"	.281"	.217"	.204"	.015"	.095"	.875"	Ⓛ
17058215	Ⓛ	Ⓛ	.469"	.281"	.217"	.204"	.015"	.095"	.875"	Ⓛ
17058513	Ⓛ	Ⓛ	.469"	.281"	.217"	.225"	.015"	.120"	.875"	Ⓛ
17058514	Ⓛ	Ⓛ	.469"	.281"	.217"	.225"	.015"	.120"	.875"	Ⓛ
17058515	Ⓛ	Ⓛ	.469"	.281"	.217"	.225"	.015"	.120"	.875"	Ⓛ
17058529	Ⓛ	Ⓛ	.469"	.281"	.217"015"	.112"	.875"	Ⓛ
17058525	Ⓛ	Ⓛ	.438"	.281"	.217"015"	.120"	.750"	Ⓛ
17058229	Ⓛ	Ⓛ	.469"	.281"	.217"	.204"	.015"	.095"	.875"	Ⓛ

- Ⓛ — See Emission Control Decal.
- Ⓛ — See Choke Coil Rod Adjustment in this article.