

# 1975-79 FUEL SYSTEMS

## Rochester 1MV 1-Barrel Carburetor

### 1975-76 General Motors

#### CARBURETOR APPLICATION

##### 1975 ROCHESTER 1MV CARBURETOR NUMBERS

Application	Man. Trans.	Auto. Trans.
250" Light Duty C10 & G10		
Federal .....	7045003 .....	7045002
Calif. ....	7045303 .....	7045302
G10		
Federal .....	7045005 .....	7045004
Calif. ....	7045305 .....	7045304
292" Heavy Duty .....	7045008 .....	7045008

##### 1976 ROCHESTER 1MV CARBURETOR NUMBERS

Application	Man. Trans.	Auto. Trans.
250" Light Duty C10 & G10		
Federal .....	17056003 .....	17056002
California .....	17056303 .....	17056302
250" Heavy Duty C10 & K10		
.....	17056007 .....	17056004, 006
20 & 30 Series		
Federal .....	17056009 .....	17056008
California .....	17056309 .....	17056308

#### CARBURETOR IDENTIFICATION

The carburetor model identification is stamped on a vertical portion of the float bowl, adjacent to the fuel inlet nut. If replacing float bowl, follow manufacturer's instructions contained in service package so that the identification number can be transferred to the new float bowl.

#### DESCRIPTION

The Rochester model 1MV carburetor is a single barrel, downdraft type carburetor using a triple venturi in conjunction with a plain tube nozzle. This model carburetor incorporates an electrically activated integral automatic choke system. The automatic choke coil is manifold mounted and connects to the choke valve by a rod.

The vacuum diaphragms are mounted externally to carburetor air horn and connect to thermostatic coil lever through a connector link. An electrically actuated idle stop solenoid and dual throttle return springs are used on all models. The vacuum supply port which operates the EGR valve is located in the throttle body and connects through a channel to tube which is located on top of air horn casting.

#### ADJUSTMENTS

##### HOT (SLOW) IDLE RPM

See appropriate article in TUNE-UP PROCEDURES section.

##### IDLE MIXTURE

See appropriate article in TUNE-UP PROCEDURES section.

##### COLD (FAST) IDLE RPM

- 1) Connect tachometer to engine. Check hot (slow) idle RPM and adjust if necessary. Ensure engine is at normal operating temperature, air cleaner is installed, choke is open, and EGR valve signal line is disconnected and plugged. Turn A/C off (if equipped).
- 2) Disconnect vacuum advance hose at distributor and plug hose. Start engine and place transmission in Neutral. Set fast idle cam follower so that tang is on highest step of cam. Bend tang in or out to obtain specified fast idle RPM.

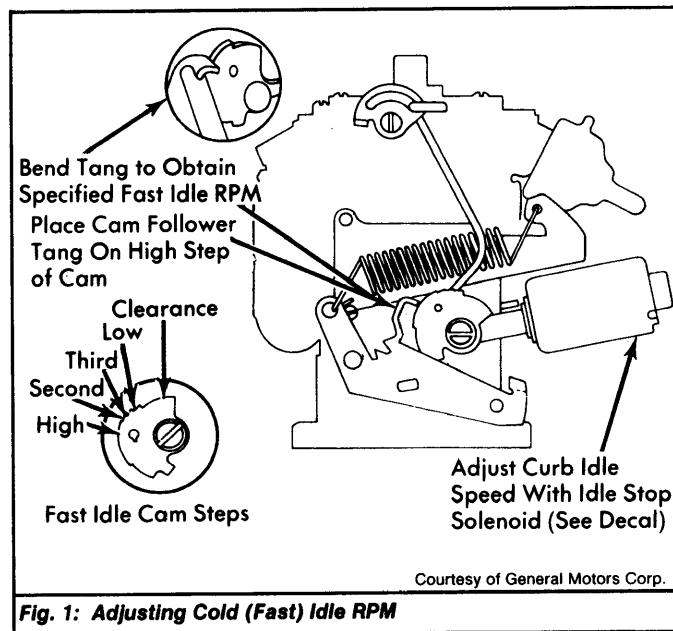

Fig. 1: Adjusting Cold (Fast) Idle RPM

##### CHOKE COIL ROD

Pull up on rod to end of travel to completely close choke valve. Bottom of rod should be even with top of lever. If adjustment is required to meet specification, bend rod. See Fig. 2.

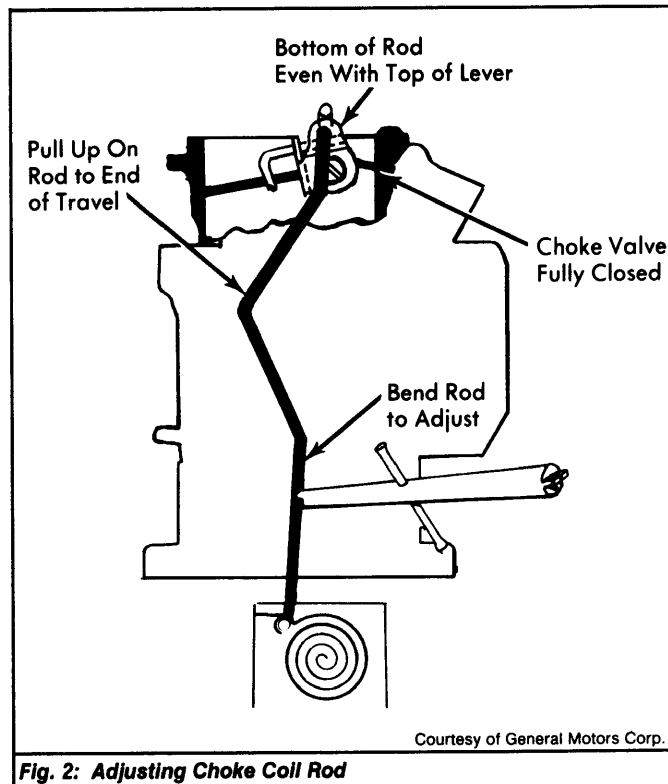

Fig. 2: Adjusting Choke Coil Rod

##### CHOKE UNLOADER

Apply light closing pressure to choke coil lever. Open throttle lever to wide open position. Measure specified clearance between upper edge of choke valve and air horn wall. See Fig. 3. To adjust, bend choke unloader tang.

# 1975-79 FUEL SYSTEMS

## Rochester 1MV 1-Barrel Carburetor (Cont.)

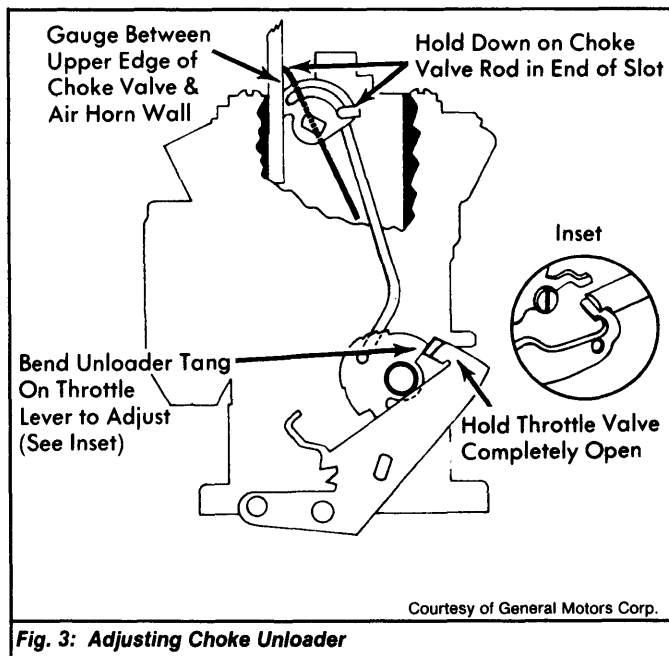

**Fig. 3: Adjusting Choke Unloader**

### PRIMARY VACUUM BREAK

- 1) Place cam follower on highest step of fast idle cam. Place a piece of masking tape over purge bleed hole in vacuum break end cover. Use outside vacuum source and apply enough vacuum to seat diaphragm. See Fig. 4. Diaphragm plunger should be fully seated.
- 2) Push up on choke coil lever. Rod should be snug in end of diaphragm plunger slot. Measure specified clearance between upper edge of choke valve and air horn wall. Measurement can be made with a specified drill or pin gauge. To adjust, bend "U" shaped portion of vacuum diaphragm connector link. Remove masking tape. Check linkage for binding.

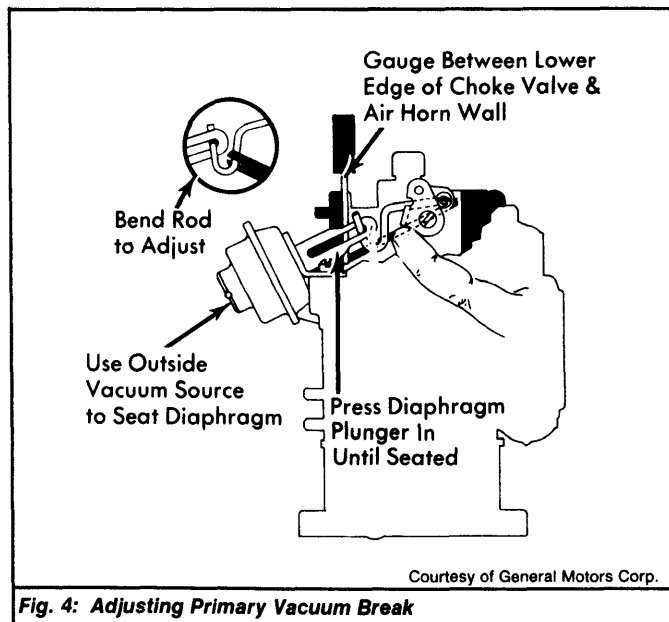

**Fig. 4: Adjusting Primary Vacuum Break**

### AUXILIARY VACUUM BREAK

Place cam follower on highest step of fast idle cam. Apply vacuum to vacuum break diaphragm until plunger is fully seated. See Fig. 5. Now insert specified gauge between upper edge of choke valve and inner air horn wall. See appropriate CARBURETOR ADJUSTMENT SPECIFICATIONS table. If necessary, bend link between vacuum break and choke valve to adjust.

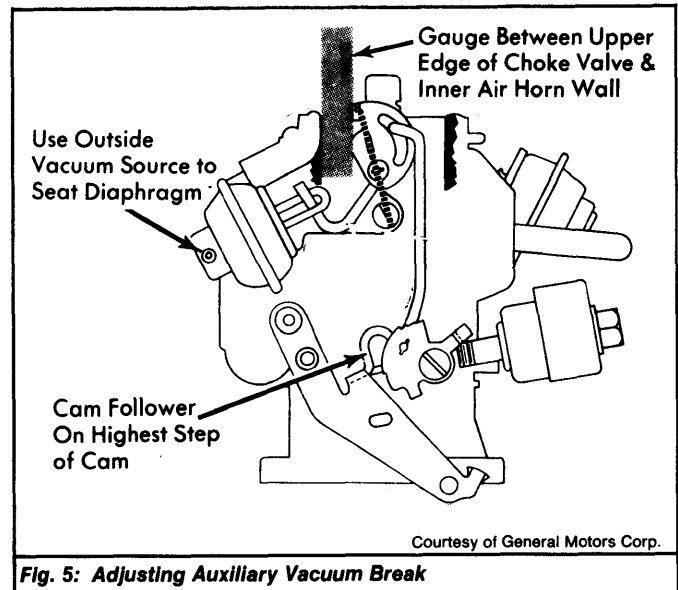

**Fig. 5: Adjusting Auxiliary Vacuum Break**

### FLOAT LEVEL

- 1) Remove air horn. Hold float pin firmly in place. Push down on end of float arm against top of float needle. See Fig. 6. With gasket removed, use a "T" scale to measure distance from top of casting to index point at toe of float.
- 2) If adjustment is needed, gently bend float arm up or down. Do not force needle against needle seat. Install new gasket, replace air horn. Start engine and check for leaks.

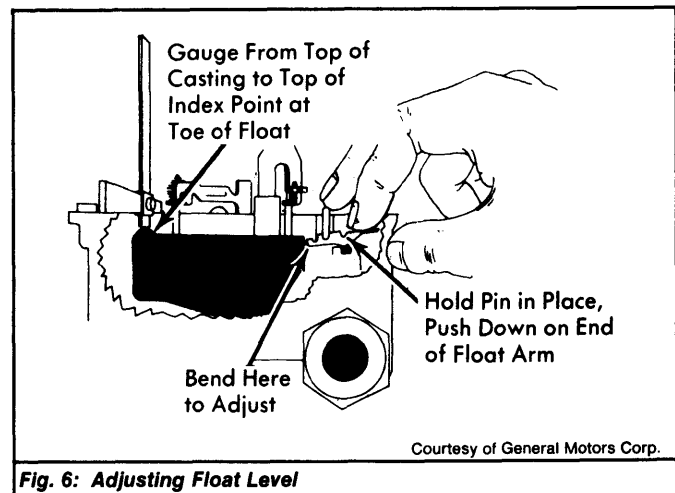

**Fig. 6: Adjusting Float Level**

### METERING ROD ADJUSTMENT

- 1) Remove air horn and gasket. Hold throttle valve wide open. Push down on metering rod against spring tension. See Fig. 7. Slide metering rod out of slot in holder and remove from main metering jet.
- 2) Back out idle stop solenoid and rotate fast idle cam so that follower is not contacting steps of cam. Hold throttle valve in fully closed position. Press down on power piston. Swing metering rod holder over flat surface of bowl casting next to bore.
- 3) Measure specified clearance between rod holder and carburetor surface. Measurement can be made using a drill or pin gauge. If adjustment is needed, gently bend holder arm up or down. Recheck clearance. Reassemble carburetor. Install new air horn-to-body gasket. Check for leaks.

# 1975-79 FUEL SYSTEMS

## Rochester 1MV 1-Barrel Carburetor (Cont.)

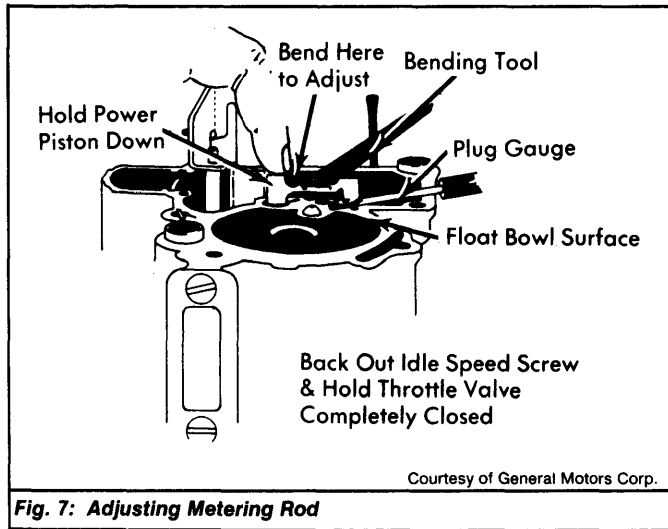

8) Push down on accelerator pump and remove actuator link. Remove pump assembly from float bowl. Remove pump return spring and power piston spring from float bowl.

9) Remove "T" guide and pump discharge spring. Invert float bowl and collect pump discharge ball and idle tube. Remove main metering jet from bottom of fuel bowl. Remove float needle seat and gasket.

10) If used, remove idle compensator cover, idle compensator, and seal from bowl recess. Remove idle stop solenoid cam. Remove fuel inlet nut and gasket. Remove fuel filter and relief spring.

11) Invert float bowl on bench and remove 2 throttle body-to float bowl attaching screws. Remove gasket. If necessary to remove idle mixture screws, cut tang from plastic limiter caps. Remove idle mixture screws.

**Cleaning & Inspection** - Use a regular carburetor cleaning solution. Soak components long enough to thoroughly clean all surfaces and passages of foreign matter. DO NOT soak any components containing rubber, leather or plastic. Remove any residue after cleaning components.

**Reassembly** - To reassemble, reverse disassembly procedure. Stake choke valve screws during reassembly being careful not to bend choke shaft. Tighten air horn screws using correct tightening sequence. See Fig. 8.

## OVERHAUL

### CARBURETOR

**Disassembly** - 1) Place carburetor on stand to prevent damaging throttle valve. Remove auxiliary vacuum break diaphragm from air horn (2 attaching screws). See Fig. 9.

2) Remove auxiliary vacuum break diaphragm plunger from link which is permanently attached to choke lever. Lever and link assembly can be removed during choke valve removal. Remove fast idle cam. Detach fast idle cam from choke rod and choke rod from upper choke lever.

3) Remove 6 air horn-to-fuel bowl attaching screws. Remove primary vacuum break diaphragm, then remove vacuum break hose assembly and link from slotted diaphragm plunger stem. Remove air horn by lifting it straight up.

4) If required, remove choke valve and choke shaft by removing screw retaining thermostatic coil lever to choke shaft. Remove 2 choke valve retaining screws. Choke valve retaining screws are staked in place. File off staking for removal. Remove choke valve and shaft from air horn.

5) Remove air horn gasket. Lift upward on float hinge pin to extract float assembly from float bowl. Remove hinge pin from float arm. Withdraw float needle from seat.

6) Disconnect accelerator pump and power piston actuator lever from end of throttle shaft. Hold down power piston while removing lever. Remove power piston and metering rod assembly.

7) Remove lower end of power piston link from actuator lever by rotating tang out of notch in lever. Remove actuator lever from lower end of accelerator pump link.

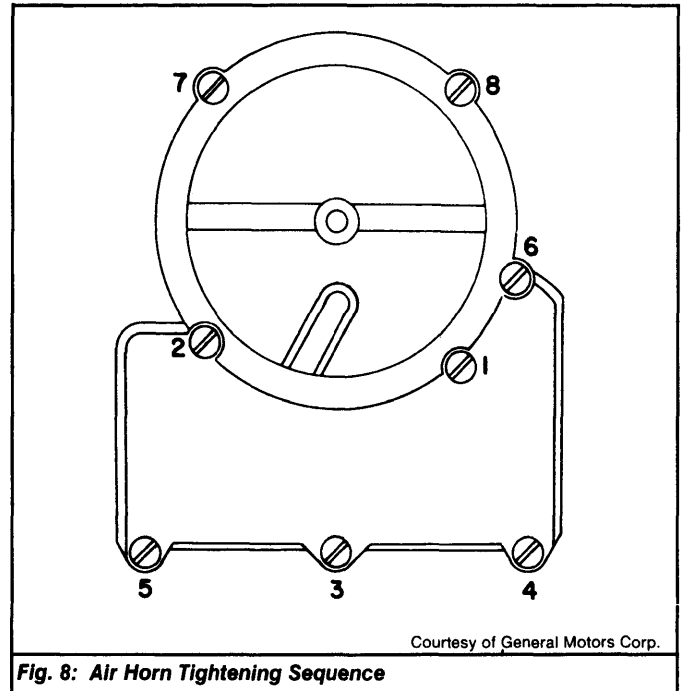

# 1975-79 FUEL SYSTEMS

## Rochester 1MV 1-Barrel Carburetor (Cont.)

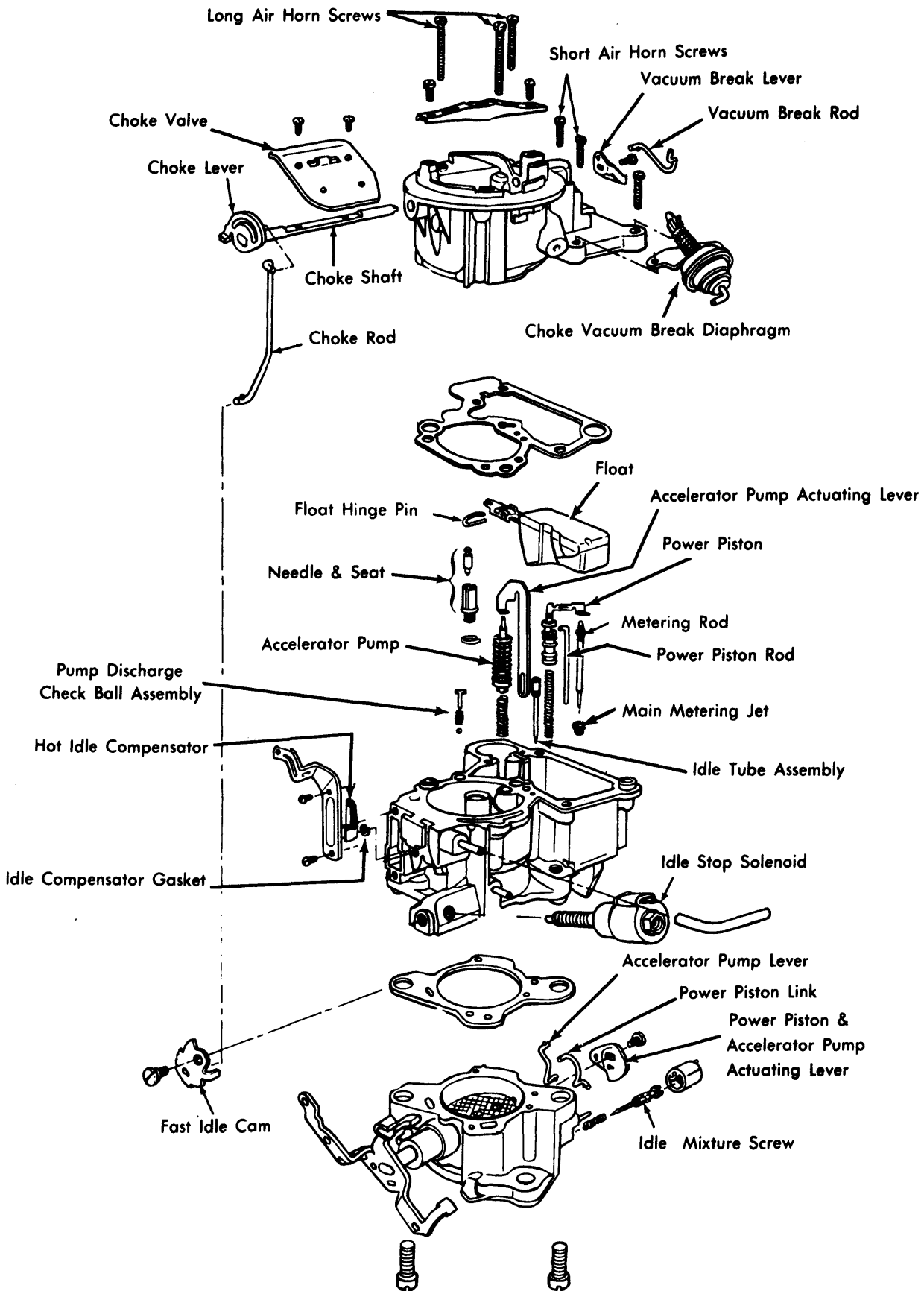

Courtesy of General Motors Corp.

Fig. 9: Exploded View of Rochester 1MV 1-Barrel Carburetor

# 1975-79 FUEL SYSTEMS

## Rochester 1MV 1-Barrel Carburetor (Cont.)

1975 CARBURETOR ADJUSTMENT SPECIFICATIONS										
Rochester Carb. No.	Idle Speed Unloader	Pump Rod	Pump Float Setting	Rod Location	Air Choke Rod	Rear Valve Dashpot	Front Vac. Break	Air Vac. Break	Choke Valve Windup	Coil Lever
5002	.325"	.080"	1 $\frac{1}{32}$ "	.....	.260"	.....	.300"	.290"	.....	.....
5003	.325"	.080"	1 $\frac{1}{32}$ "	.....	.275"	.....	.300"	.290"	.....	.....
5004	.325"	.080"	1 $\frac{1}{32}$ "	.....	.245"	.....	.300"	.150"	.....	.....
5005	.325"	.080"	1 $\frac{1}{32}$ "	.....	.275"	.....	.350"	.290"	.....	.....
5008	.....	.....	.....	.....	.....	.....	.....	.....	.....	.....
5302	.275"	.080"	1 $\frac{1}{32}$ "	.....	.245"	.....	.300"	.150"	.....	.....
5303	.275"	.080"	1 $\frac{1}{32}$ "	.....	.275"	.....	.350"	.170"	.....	.....
5304	.275"	.080"	1 $\frac{1}{32}$ "	.....	.245"	.....	.300"	.290"	.....	.....
5305	.325"	.080"	1 $\frac{1}{32}$ "	.....	.275"	.....	.350"	.290"	.....	.....

1976 CARBURETOR ADJUSTMENT SPECIFICATIONS								
Carb. No.	Idle Speed (Engine RPM)		Float Level Setting	Metering Rod Setting	Choke Unloader Setting	Primary Vacuum Break	Aux. Vacuum Break	Choke Coil Rod
	Hot	Fast						
6002	550	2100	1 $\frac{1}{32}$ "	.080"	.335"	.165"	.265"	.130"
6003	900	2100	1 $\frac{1}{32}$ "	.080"	.335"	.180"	.....	.145"
6004	600	2400	1 $\frac{1}{32}$ "	.080"	.335"	.165"	.265"	.130"
6006	600	2400	1 $\frac{1}{4}$ "	.080"	.270"	.165"	.....	.130"
6007	600	2400	1 $\frac{1}{4}$ "	.070"	.275"	.165"	.....	.130"
6008	600	2400	1 $\frac{1}{4}$ "	.070"	.275"	.190"	.....	.150"
6009	600	2400	1 $\frac{1}{4}$ "	.070"	.275"	.190"	.....	.150"
6302	600	2100	1 $\frac{1}{32}$ "	.080"	.325"	.190"	.....	.155"
6303	1000	2100	1 $\frac{1}{32}$ "	.080"	.325"	.225"	.....	.180"
6308	600	2400	1 $\frac{1}{4}$ "	.070"	.275"	.190"	.....	.150"
6309	600	2400	1 $\frac{1}{4}$ "	.070"	.275"	.190"	.....	.150"