

# 1975-79 FUEL SYSTEMS

## Holley 4180-C 4-Barrel Carburetor

1979 Ford Motor Co.

### CARBURETOR APPLICATION

#### FORD MOTOR CO.

Application	Ford Carb. No. Man. Trans.	Ford Carb. No. Auto. Trans.
460"		
Federal .....		D9TE-AEA, BKA
California .....		D9TE-AGA

### CARBURETOR IDENTIFICATION

A carburetor identification tag is attached to carburetor. The tag contains part number prefix and suffix. Basic part number for all carburetors is 9510. A design change code (if any) and an assembly date code (year, month and day) is also stamped on the tag.

### DESCRIPTION

The Holley 4180-C carburetor consists of 3 main components. The primary fuel bowl, secondary fuel bowl and main throttle body. Both primary and secondary fuel bowl assemblies are connected to the main fuel inlet system. All models are equipped with an automatic choke. Vehicles under 8500 lbs. GVW are equipped with an electric assist type choke. Vehicles over 8500 lbs. GVW utilize a hot air type automatic choke.

This model carburetor has a modulated power valve system. This system ensures power valve opening when manifold vacuum increases (during full acceleration) beyond the point where power valve would normally start to close. Vacuum will bleed off whenever throttle valve opening is 50 degrees or more.

### ADJUSTMENTS

#### HOT (SLOW) IDLE RPM

See appropriate article in TUNE-UP PROCEDURES section.

#### DECEL THROTTLE MODULATOR

See appropriate article in TUNE-UP PROCEDURES section.

#### IDLE MIXTURE

See appropriate article in TUNE-UP PROCEDURES section.

#### COLD (FAST) IDLE RPM

See appropriate article in TUNE-UP PROCEDURES section.

#### ACCELERATOR PUMP LEVER

1) Open throttle valves wide open. Using a feeler gauge, measure specified clearance between the lever adjustment screw head and

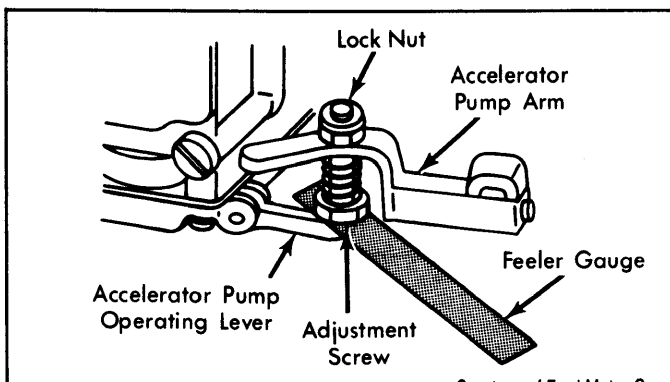

Fig. 1: Accelerator Pump Lever Adjustment

pump arm with the pump arm manually open. See Fig. 1.

2) To adjust, loosen adjustment screw lock nut. Turn adjusting screw in to increase clearance and out to decrease clearance. Tighten lock nut.

**NOTE: One-half turn of adjustment screw is equal to .015".**

#### ACCELERATOR PUMP STROKE

1) Accelerator pump stroke has been preset at factory. Setting should not be changed. If original setting has been changed, check that plastic accelerator pump cam is aligned with correct hole (top or bottom) in throttle lever.

2) If not aligned with correct hole, remove screw. Reposition in correct hole. Install and tighten screw.

#### FLOAT LEVEL (DRY SETTING)

**NOTE: Dry float setting is a preliminary adjustment only. Final adjustment (wet setting) must be made after carburetor is installed on vehicle.**

Remove float bowl. Hold carburetor upside-down. Float is adjusted correctly if top of float is parallel with float bowl. See Fig. 2. To adjust, loosen lock nut and turn adjusting nut until float is parallel.

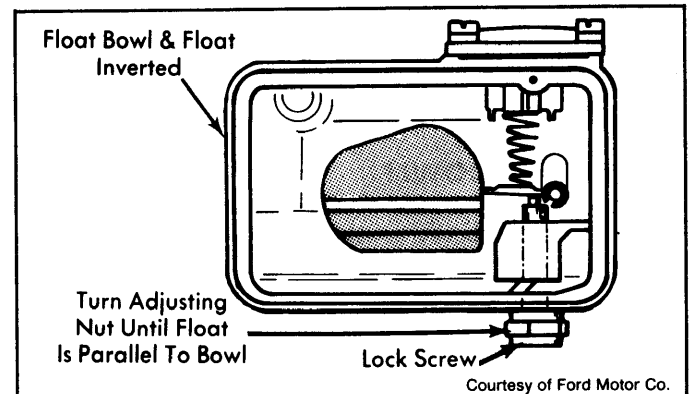

Fig. 2: Float Level Adjustment (Dry Setting)

#### FLOAT LEVEL (WET SETTING)

1) With engine at normal operating temperature, place vehicle on a flat, level surface. Remove air cleaner. Check fuel level at each float bowl separately. See Fig. 3.

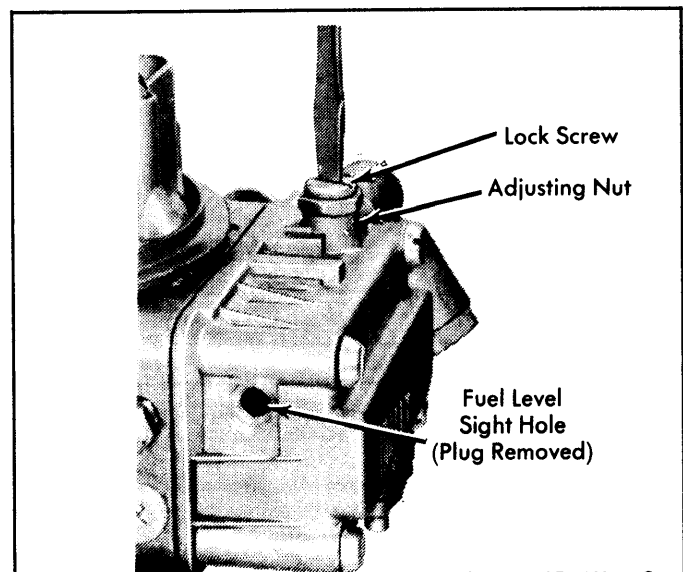

Fig. 3: Float Level Adjustment (Wet Setting)

# 1975-79 FUEL SYSTEMS

## Holley 4180-C 4-Barrel Carburetor (Cont.)

2) Place a container under primary float bowl sight plug. With engine running, remove plug and gasket. Fuel level should be at lower edge of plug opening.

3) If float level is too high, stop engine and drain fuel bowl by removing one of the lower float bowl screws. Drain fuel into a container. Tighten fuel bowl screw.

**NOTE: Engine should be restarted to fill fuel bowl. This will make sure that foreign material did not cause a temporary flooding condition.**

4) If float level is still too high, it should be lowered then raised to correct level. Remove both secondary and primary sight plugs and gaskets.

5) Loosen float adjustment lock screw on top of primary float bowl. Turn adjustment nut clockwise to lower fuel level below sight plug opening.

6) Now turn adjustment nut counterclockwise until fuel level just reaches lower edge of sight plug hole. Tighten lock screw. Allow fuel level to stabilize to check for correct level. Install sight plug and gasket.

7) If the float level was too low during original checking procedure, follow step 6).

### SECONDARY THROTTLE VALVES

Hold secondary throttle valves closed. Turn secondary throttle valve stop screw out until secondary throttle valves seat in throttle bores. Now turn screw in until screw just contacts secondary throttle valve lever.

### CHOKE PULL-DOWN

1) Remove choke thermostat housing, gasket and retainer. Insert a .026" wire gauge into choke piston bore. This moves piston down against stop screw. See Fig. 4.

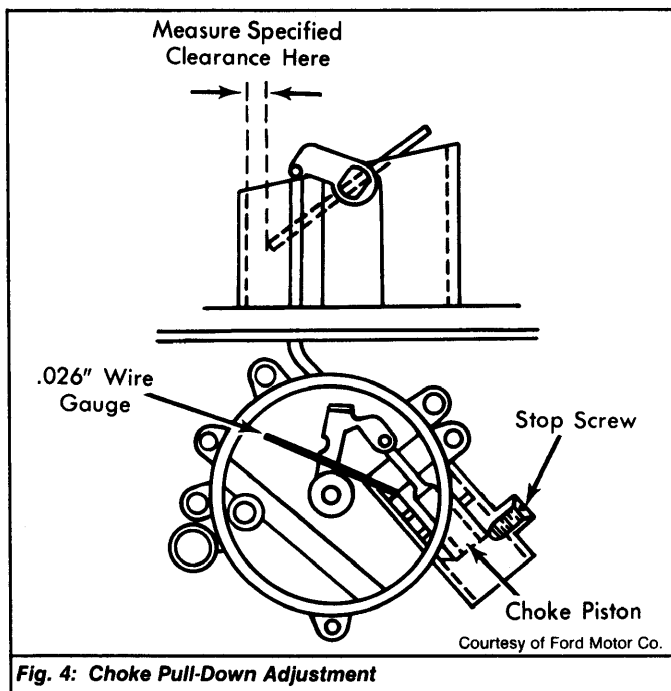

**Fig. 4: Choke Pull-Down Adjustment**

2) Hold choke valve toward closed position. Measure specified choke pull-down clearance between lower edge of choke valve and air horn wall.

3) If adjustment is necessary, remove putty covering stop screw. Turn screw clockwise to increase clearance and counterclockwise to decrease clearance.

### FAST IDLE CAM

1) Loosen choke thermostat housing screws. Rotate housing 45 degrees counterclockwise (rich) to close choke valve. Tighten choke housing screws. See Fig. 5.

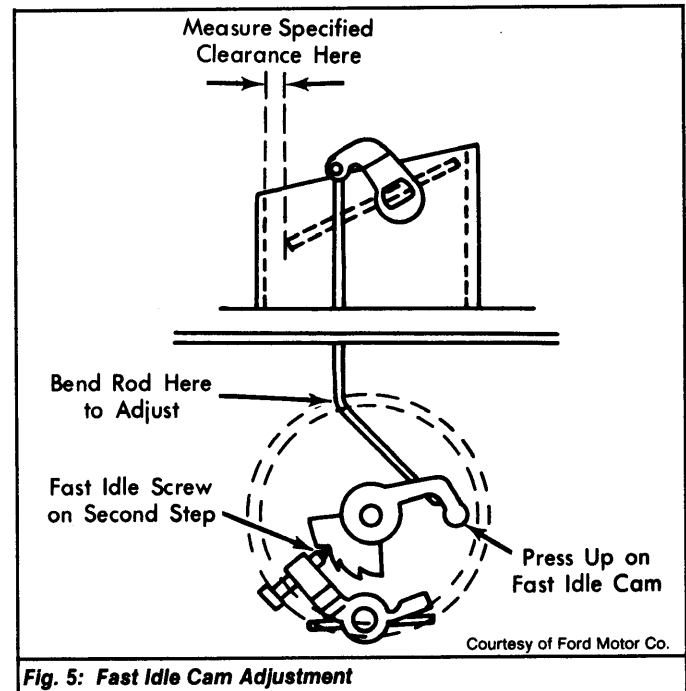
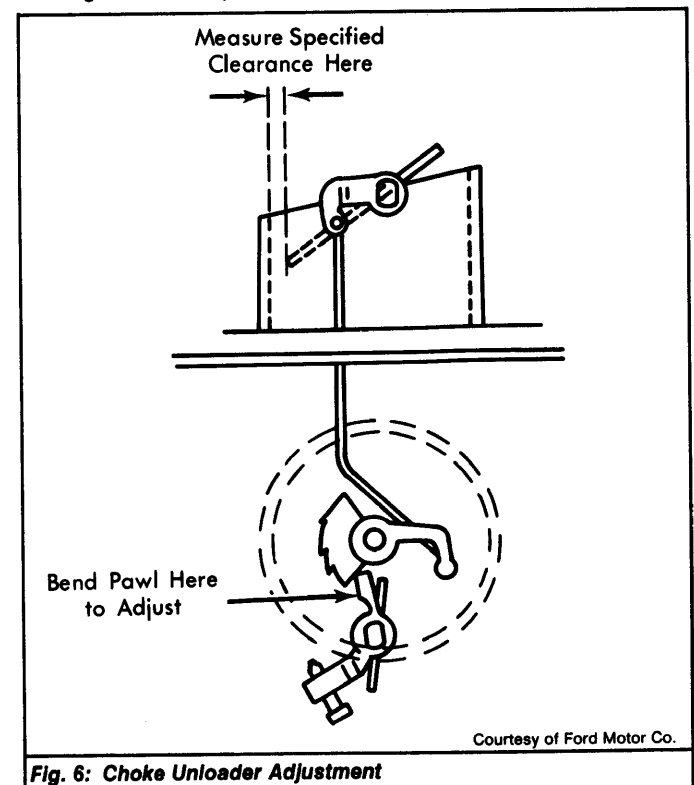

**Fig. 5: Fast Idle Cam Adjustment**

2) Open then close throttle. This will position fast idle speed screw on top step of fast idle cam.

3) Insert a specified gauge between lower edge of choke valve and air horn wall. Open and close throttle and allow fast idle cam to drop.

4) Press up on fast idle cam. There should be little or no movement. This indicates that fast idle screw is on second (kickdown) step of cam, against first step.



**Fig. 6: Choke Unloader Adjustment**

# 1975-79 FUEL SYSTEMS

## Holley 4180-C 4-Barrel Carburetor (Cont.)

2-57

5) To adjust, bend choke control rod until fast idle screw is in correct position on fast idle cam. Readjust automatic choke to correct setting and tighten screws.

### CHOKE UNLOADER

- 1) Hold throttle valves wide open. Apply light closing pressure on choke valve. See Fig. 6.
- 2) Measure specified choke unloader clearance between lower edge of choke valve and air horn wall. To adjust, bend pawl on fast idle cam lever.

### AUTOMATIC CHOKE

Loosen choke thermostat cover retaining screws. Rotate cover assembly in "Rich" or "Lean" direction to align reference mark on cover with specified scale graduation in housing. Tighten cover screws.

## OVERHAUL

### CARBURETOR

**Disassembly (Primary Fuel Bowl & Metering Block) – 1)** Remove primary fuel bowl and gasket. Remove metering block and gasket.

- 2) Remove pump transfer tube and "O" rings from main body if it was not removed with metering block.
- 3) Remove fuel line tube and "O" rings. Remove balance tube, washer and "O" ring seal.
- 4) Remove idle mixture screws and gaskets. Remove main jets and power valve from metering block.
- 5) Remove fuel level adjustment lock screw and gasket. Turn adjusting nut counterclockwise and remove nut and gasket.
- 6) Remove fuel inlet needle and seat assembly. Do not disassemble needle and seat, they are replaced as an assembly.
- 7) Remove float retainer using a pair of needle nose pliers. Slide float off shaft and remove spring from float.
- 8) Remove baffle plate from fuel bowl. Remove fuel level sight plug and gasket. Remove fuel inlet fitting, gasket and screen.
- 9) Invert fuel bowl. Remove accelerator pump cover, diaphragm and spring. Do not remove accelerator pump inlet check ball.

**Disassembly (Secondary Fuel Bowl & Metering Block) – 1)** Remove fuel bowl. Using a clutch type screwdriver, remove metering block screws. Remove metering block, plate and gasket.

2) Remove balance tube, washer and "O" ring seal. Disassemble fuel bowl by following step 5) through 8) in Primary Fuel bowl assembly.

**Disassembly (Main Body) – 1)** Remove air cleaner stud. Remove secondary diaphragm link retainer.

- 2) Invert carburetor. Remove throttle body screws and lock washers. Lift throttle body off main body and remove gasket.
- 3) Remove choke rod retainer from choke housing shaft and lever assembly. Remove choke cover, thermostatic spring and gasket. Remove choke main housing and gaskets.
- 4) Remove choke housing shaft nut, lock washer and spacer. Remove shaft and fast idle cam. Remove choke piston and lever assembly.

**NOTE: If it is necessary to remove choke valve and shaft, tips of choke valve screws may have to be filed as they are staked into shaft.**

- 5) If it is necessary, remove choke valve screws. Remove choke valve and slide out choke shaft.
- 6) Remove secondary diaphragm housing and gasket. Remove diaphragm housing cover, spring diaphragm and vacuum check ball.

**NOTE: The secondary diaphragm housing must be removed before attempting to remove cover.**

7) Remove accelerator pump discharge nozzle screw. Lift off discharge nozzle and gasket. Invert main body and catch accelerator pump discharge needle as it falls out of bore in main body.

**Disassembly (Throttle Body) –** Components of throttle body are matched to meet emission control standards. Manufacturer does not recommend disassembly of throttle body.

**Cleaning & Inspection –** Use a regular carburetor cleaning solution. Soak components long enough to thoroughly clean all surfaces and passages of foreign matter. Do not soak any components containing rubber, leather or plastic. Remove any residue after cleaning by rinsing components in a suitable solvent. Blow out all passages with dry compressed air.

**Reassembly (Main Body) – 1)** Drop accelerator pump discharge needle into bore in main body. Using a brass drift punch and hammer, lightly seat needle in bore.

2) Place accelerator pump discharge nozzle and gasket in position on main body. Install and tighten screw. Use new gaskets and seals. Make sure that new gaskets fit correctly and that all holes and slots are punched through and correctly located.

3) Drop vacuum check ball into bore in secondary diaphragm housing. Place secondary diaphragm in housing and spring in cover. Install cover and tighten screws finger tight.

4) Make sure diaphragm is seated correctly on housing and that vacuum passage is aligned. Tighten cover screws.

5) Position secondary diaphragm housing gasket on main body. Install diaphragm housing on main body. Install and tighten screws.

6) If removed, slide choke shaft into position in main body. Install choke plate in shaft. Install screws and tighten. Carefully stake screws in place.

7) Install rod seal on choke rod. Slide "U" end of choke plate rod through opening in main body. Insert the rod end through the inner side of bore in choke lever. Make sure rod end faces outward.

8) Push rod seal into retaining grooves on underside of air cleaner mounting flange. Install choke thermostat lever link and piston assembly in choke housing.

9) Install fast idle cam assembly on choke housing. Install choke housing shaft and lever assembly. Place lever and piston-assembly on choke housing shaft and lever assembly. Install spacer, lock washer and nut.

10) Place main body on its side. Position choke housing gaskets on main body. As choke housing is layed into position, insert choke rod in choke housing shaft.

**NOTE: Make sure projection on choke rod is positioned under fast idle cam to ensure that cam will be lifted when choke plate is closed.**

11) Install choke housing screws and lock washers. Install choke rod retainer using a pair of needle nose pliers.

12) Install choke thermostatic spring housing gasket into position on choke housing. Make sure spring engages spring lever. Install cover, retainer and screws. Adjust automatic choke.

13) Invert main body. Place throttle body gasket in position on main body. Place throttle body in position on main body. Throttle body should be positioned so that fuel inlet fitting is on same side as accelerator pump operating lever.

14) As throttle body is being positioned, slide secondary diaphragm rod onto operating lever. Install throttle body screws and washers. Install secondary diaphragm retainer. Install air cleaner stud.

**Reassembly (Primary Fuel Bowl & Metering Block) – 1)** Position accelerator pump diaphragm spring and diaphragm in accelerator pump chamber. Position diaphragm so that large end of rivet is against operating lever.

2) Install accelerator pump cover and tighten screws finger tight. Make sure diaphragm is centered. Compress diaphragm with lever and tighten screws.

3) Install filter screen, gasket and fuel inlet fitting. Install fuel level sight plug and gasket. Insert baffle plate into notches in fuel bowl.

4) Install float spring onto float. Slide float onto shaft. Make sure float spring is between ridges on bottom side of fuel bowl.

5) Apply petroleum jelly to a new "O" ring and slide "O" ring onto fuel inlet needle and seat assembly.

# 1975-79 FUEL SYSTEMS

## Holley 4180-C 4-Barrel Carburetor (Cont.)

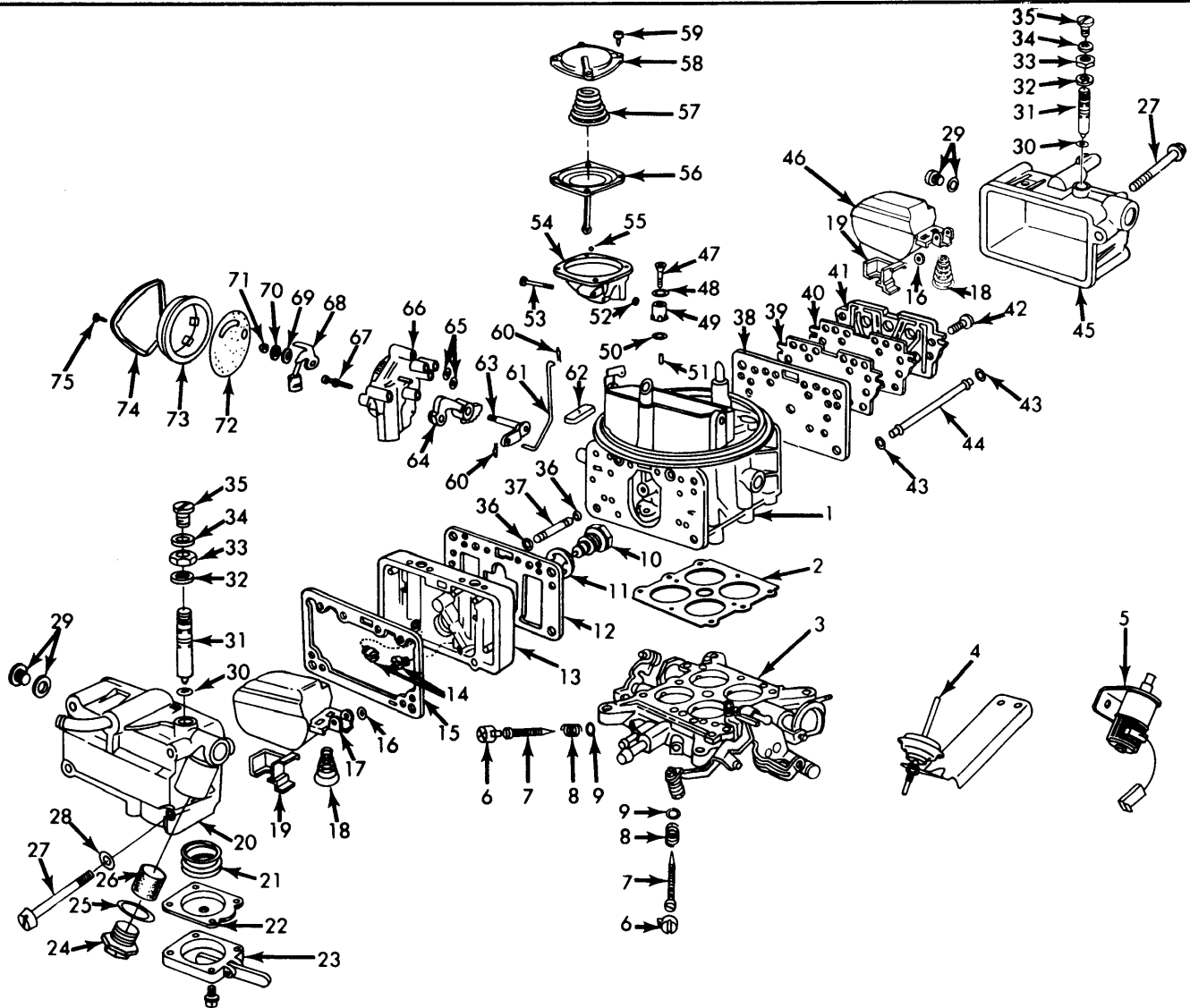

- |  |   |  |
|--|---|--|
| 1. Main Body   | 26. Fuel Filter                               | 53. Secondary Vacuum Diaphragm Housing Screw |
| 2. Throttle Body Gasket  | 27. Fuel Bowl Screw                           | 54. Secondary Vacuum Diaphragm Housing       |
| 3. Throttle Body   | 28. Fuel Bowl Screw Gasket                    | 55. Secondary Vacuum Diaphragm Check Ball    |
| 4. Decel Throttle Modulator (Vehicles Over 8500 Lbs. GVW)      | 29. Fuel Bowl Sight Plug & Gasket             | 56. Secondary Vacuum Diaphragm               |
| 5. Solenoid Throttle Positioner (Vehicles Under 8500 Lbs. GVW) | 30. Needle & Seat "O" Ring                    | 57. Secondary Vacuum Diaphragm Spring        |
| 6. Idle Limiter Cap  | 31. Needle & Seat Assy.                       | 58. Secondary Vacuum Diaphragm Cover         |
| 7. Idle Mixture Screw  | 32. Fuel Level Adjustment Nut Gasket          | 59. Secondary Vacuum Diaphragm Cover Screw   |
| 8. Idle Mixture Screw Spring                                   | 33. Fuel Level Adjustment Nut                 | 60. Choke Rod Clip                           |
| 9. Idle Mixture Screw Gasket                                   | 34. Fuel Level Adjustment Lock Screw Gasket   | 61. Choke Rod                                |
| 10. Power Valve  | 35. Fuel Level Adjustment Lock Screw          | 62. Choke Rod Seal                           |
| 11. Power Valve Gasket   | 36. Accel. Pump Transfer Tube "O" Ring        | 63. Choke Rod Shaft & Lever                  |
| 12. Primary Metering Block Gasket                              | 37. Accel. Pump Transfer Tube                 | 64. Fast Idle Cam                            |
| 13. Primary Metering Block                                     | 38. Secondary Plate Gasket                    | 65. Choke Housing Gasket                     |
| 14. Main Jets  | 39. Secondary Plate                           | 66. Choke Housing                            |
| 15. Primary Fuel Bowl Gasket                                   | 40. Secondary Metering Block Gasket           | 67. Choke Housing Screw                      |
| 16. Float Retainer   | 41. Secondary Metering Block                  | 68. Choke Thermostat Lever & Piston          |
| 17. Primary Float  | 42. Secondary Metering Block Screw            | 69. Washer                                   |
| 18. Float Spring   | 43. Fuel Transfer Tube "O" Ring               | 70. Spacer                                   |
| 19. Baffle Plate   | 44. Fuel Transfer Tube                        | 71. Nut                                      |
| 20. Primary Float Bowl   | 45. Secondary Float Bowl                      | 72. Choke Thermostat Cover Gasket            |
| 21. Accel. Pump Spring   | 46. Secondary Float                           | 73. Choke Thermostat Cover                   |
| 22. Accel. Pump Diaphragm                                      | 47. Accel. Pump Discharge Nozzle Screw        | 74. Choke Thermostat Cover Retainer          |
| 23. Accel. Pump Cover  | 48. Accel. Pump Discharge Nozzle Screw Gasket | 75. Choke Thermostat Cover Retainer Screw    |
| 24. Fuel Inlet Fitting   | 49. Accel. Pump Discharge Nozzle              |  |
| 25. Fuel Inlet Fitting Gasket                                  | 50. Accel. Pump Discharge Nozzle Gasket       |  |
|  | 51. Accel. Pump Discharge Needle              |  |
|  | 52. Secondary Vacuum Diaphragm Housing Gasket |  |

Courtesy of Ford Motor Co.

Fig. 7: Exploded View of Holley Model 4180-C 4-Barrel Carburetor

# 1975-79 FUEL SYSTEMS

## Holley 4180-C 4-Barrel Carburetor (Cont.)

- 6) Install needle and seat assembly through top of fuel bowl. Install adjusting nut and gasket. Align flat on inside of nut with flat on outside of needle and seat assembly.
- 7) Install fuel level adjustment lock screw. Perform dry float level setting now.
- 8) Install power valve and gasket in metering block. Install pump transfer tube and new "O" rings in metering block. Install main jets in metering block.
- 9) Install idle mixture screws with new gaskets. Turn mixture screws in until they are lightly seated, then back out 2 turns for a preliminary idle mixture adjustment.
- 10) Slide balance tube through holes in primary and secondary side of main body. Position tube so that ends protrude equally from both sides.
- 11) Apply petroleum jelly to new "O" ring. Install "O" ring on primary end of tube. Slide washer on against "O" ring. Push "O" ring and washer into recess in main body.
- 12) Install metering block gasket on dowels on back of metering block. Position metering block and gasket on main body. Install baffle plate and gasket on metering block.

13) Install new gaskets on fuel bowl screws. Position fuel bowl on metering block and tighten screws.

14) Apply petroleum jelly to fuel line tube "O" ring. Place "O" ring against flange on end of fuel line tube. Place "O" ring end of tube into fuel bowl recess.

**Reassembly (Secondary Fuel Bowl & Metering Block) - 1)** Assemble fuel bowl and perform dry float level setting Position metering body gasket in place on main body over balance tube. Install metering plate, gasket and metering block on main body. Install and tighten clutch head type screws.

2) Adjust balance tube so that it extends 1" from metering body. Apply petroleum jelly to fuel line tube "O" ring. Place "O" ring against flange on end of fuel line tube.

3) Install fuel bowl on main body, guiding fuel line tube into recess in fuel bowl. Install new gaskets on screws. Install screws in fuel bowl and tighten.

<b>1979 CARBURETOR ADJUSTMENT SPECIFICATIONS</b>						
<b>Carb. No.</b>	<b>Accelerator Pump</b>		<b>Choke Pulldown Setting</b>	<b>Fast Idle Cam Setting</b>	<b>Choke Unloader Setting</b>	<b>Auto. Choke Setting</b>
	<b>Lever (Clearance)</b>	<b>Stroke (Hole No.)</b>				
D9TE-AEA	.015"	#1	.210"	.210"	.315"	5NR
D9TE-AGA	.015"	#1	.210"	.210"	.315"	5NR
D9TE-BKA	.015"	#1	.210"	.210"	.315"	5NR