

1975-79 FUEL SYSTEMS

Holley 1940 1-Barrel Carburetor

1975-79 International Harvester

CARBURETOR APPLICATION

INTERNATIONAL HARVESTER CO.

Application	Holley No.
196" 4-Cyl.	
1975	7161
1976	7161A
1977	
Federal	7161A
California	7576A
1978	
Federal	7161
California	7576, 8239
1979	7771

DESCRIPTION

Holley 1940 is of a single venturi downdraft design. Fuel bowl completely surrounds venturi. Carburetor consists of three main parts; bowl cover, main body and throttle body. Carburetor includes 4 basic metering systems; idle and transfer, main metering system, accelerating system and power enrichment system. Other systems include the fuel inlet and electric choke systems.

TESTING

ELECTRIC CHOKE

1) With ignition switch in the "ON" position and cylinder head temperature above $130^{\circ} \pm 8^{\circ}\text{F}$, the choke heat sensor switch should be closed and full battery voltage present at carburetor side of heat sensor switch. If voltage is zero, check voltage at battery side of heat sensor switch. If voltage is again zero, check choke circuit fuse and related wire harness.

2) If voltage at battery side of switch is okay and engine temperature is above 138°F , with no voltage flow through switch, replace switch assembly. If full battery voltage is obtained at carburetor side of switch but choke fails to open, check choke plate and shaft for binding. If no binding condition exists, connect an ammeter in series between switch and electric choke. If a minimum reading of .5 amp is not obtained, replace electric choke unit.

NOTE: Temperature sensor reopens at temperatures of 80-105°F.

ADJUSTMENTS

HOT (SLOW) IDLE RPM

See appropriate article in TUNE-UP PROCEDURES section.

COLD (FAST) IDLE RPM

See appropriate article in TUNE-UP PROCEDURES section.

ACCELERATOR LINKAGE

See appropriate article in TUNE-UP PROCEDURES section.

FLOAT LEVEL

1) Remove air horn. Remove gasket. Place straight edge across surface of float bowl. Gently press needle valve in toward closed position. Do not apply heavy pressure or damage may result to tip of needle valve.

2) While holding float tang against closed needle valve, top of floats should just touch bottom of straight edge. If adjustment is needed, bend float tang and recheck. See Fig. 1.

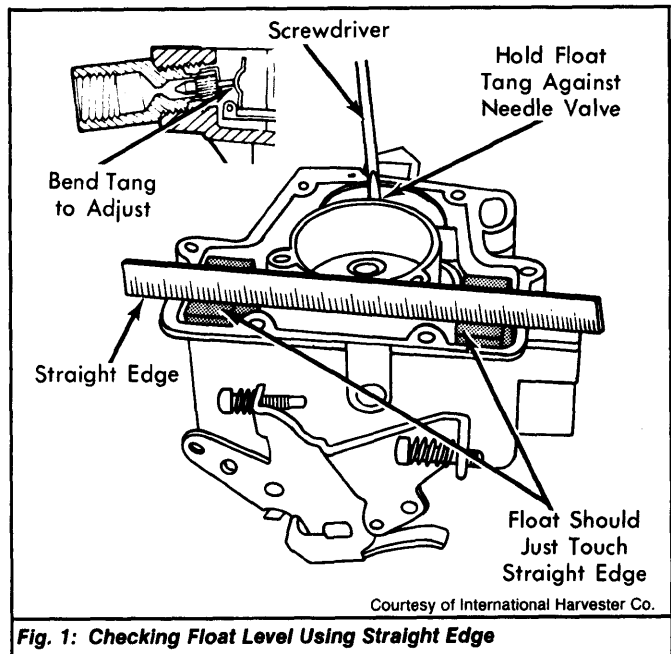

Fig. 1: Checking Float Level Using Straight Edge

FUEL LEVEL

With engine at normal operating temperature, remove air horn and measure distance from top of float bowl down to fuel level. Distance should be $1\frac{1}{16} \pm \frac{1}{32}$ ". If adjustment is necessary, bend float tang.

ACCELERATOR PUMP STROKE

1) Back idle speed screw off until throttle valves are closed completely. Measure specified accelerator pump stroke distance from vacuum passage casting to center of hole in pump operating lever. See Fig. 2.

2) To adjust accelerator pump stroke, bend operating rod at existing "U" bend.

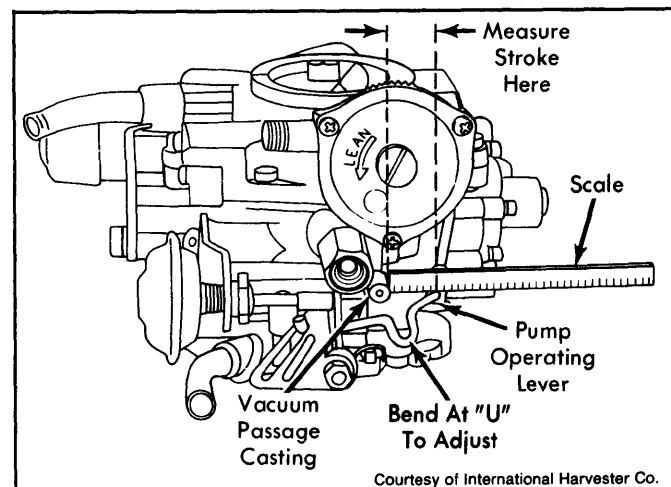

Fig. 2: Adjusting Accelerator Pump Piston Stroke

FAST IDLE CAM POSITION

NOTE: This adjustment is necessary to assure time at which each cam step occurs during engine warm-up.

1) Place fast idle speed adjusting screw on second highest step of fast idle cam, against shoulder of high step. See Fig. 3.

2) With fingers, press choke plate gently towards closed position. Do not force the plate. Ensure all slack is removed from linkage.

1975-79 FUEL SYSTEMS

Holley 1940 1-Barrel Carburetor (Cont.)

2-29

3) Measure fast idle cam position specified clearance between upper edge of choke valve and air horn wall. Measurement can be made with a drill or pin gauge of specified size. See appropriate CARBURETOR ADJUSTMENT SPECIFICATIONS table.

4) If clearance is not to specification, bend fast idle cam connecting rod.

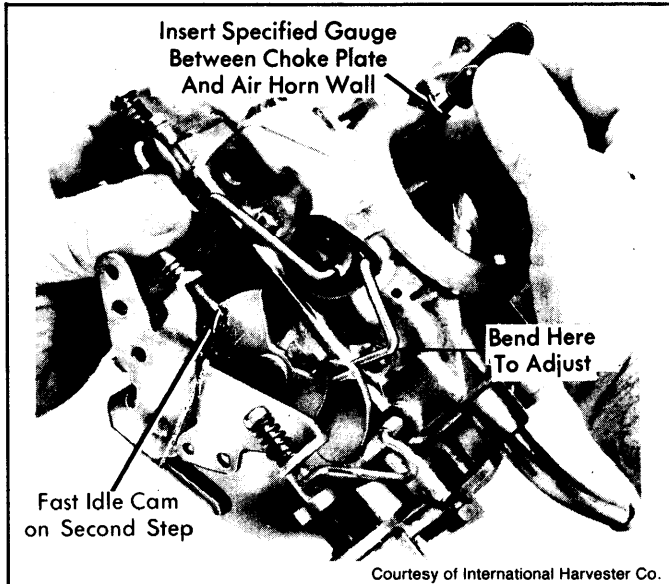

Fig. 3: Fast Idle Cam Position Adjustment

CHOKE UNLOADER

1) Open throttle valves wide open. Apply a light closing pressure to choke valve. Measure choke unloader specified clearance between upper edge of choke valve and air horn wall. See Fig. 4.

2) Measurement can be made using a drill or pin gauge of specified size. Adjust clearance by bending choke unloader tang on throttle lever.

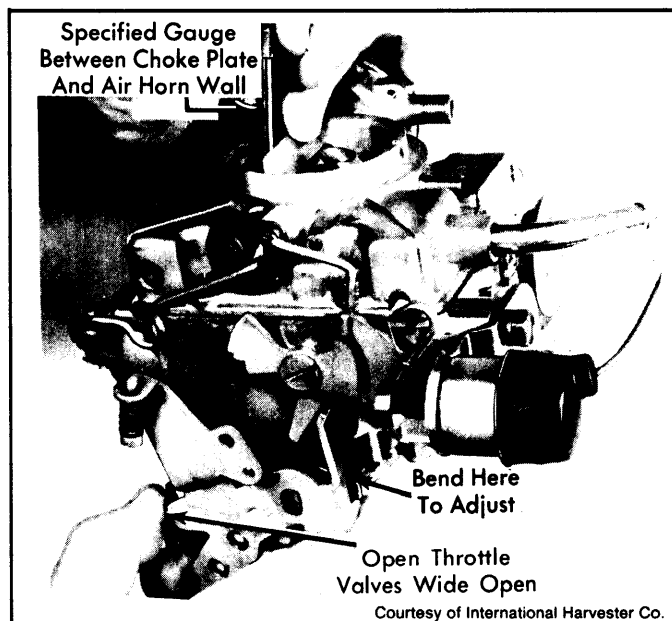

Fig. 4: Adjusting Choke Unloader

AUTOMATIC CHOKE

Loosen choke cover retaining screws. Rotate cover to align proper marks on choke housing and choke coil cover. Set coil cover to one notch rich. Tighten retaining screws.

OVERHAUL

CARBURETOR

Disassembly - 1) Remove choke cover screws and retainer ring. Remove choke cover. Remove idle speed solenoid and bracket. Remove fast idle cam screw, cam and link.

2) Remove nut and washer from accelerator pump rocker arm. Note position of rocker arm spring end tabs for reassembly. Remove rocker arm, link and spring. Separate link from rocker arm.

3) Remove air horn retaining screws and separate air horn from carburetor. Remove accelerator pump operating rod retainer screw and retainer. Rotate pump operating rod and disconnect pump drive spring and accelerator pump assembly. Rotate pump operating rod and remove from air horn.

4) Using a sharp pointed punch, remove staking from around edge of vacuum piston retainer. Remove vacuum piston with a pair of needle nose pliers.

5) Remove hot idle compensator valve cover, valve and gasket. If necessary, remove staking from choke valve screws and remove screws. Slide valve out of shaft and shaft out of air horn.

6) Turn main body up-side down and remove pump discharge check ball and weight. Withdraw spring float shaft retainer, float shaft, and float assembly. Remove fuel inlet fitting and valve assembly. Remove main jet and power valve from main body. Remove main body-to-throttle body attaching screws, separate parts, and discard gasket.

7) Turn idle mixture screw to leanest position and remove limiter cap. Turn idle mixture screw clockwise until it seats, counting total number of turns. Record number of turns for reassembly reference. Remove curb idle speed screw and spring, low idle speed screw and spring, and fast idle speed screw and spring. Inspect throttle body for nicks, burrs, or a worn shaft.

NOTE: Do not disassemble throttle body any further.

Cleaning & Inspection - 1) Use a regular carburetor cleaning solution. Soak components long enough to thoroughly clean all surfaces and passages of foreign matter.

2) Do not soak any components containing rubber, leather or plastic. Remove any residue after cleaning by rinsing components in solvent. Blow out all passages with dry compressed air.

Reassembly - 1) Using all new gaskets, reverse disassembly procedures. Before installing vacuum piston, be sure to remove all staking from retainer cavity. Install vacuum cylinder, seat retainer and stake lightly.

2) Test accelerator pump discharge valve prior to assembly by filling fuel bowl with gasoline. While holding pump discharge weight down, operate pump plunger. If no resistance is felt, pump discharge check ball is leaking. Stake check ball with drift punch and test again.

1975-79 FUEL SYSTEMS

Holley 1940 1-Barrel Carburetor (Cont.)

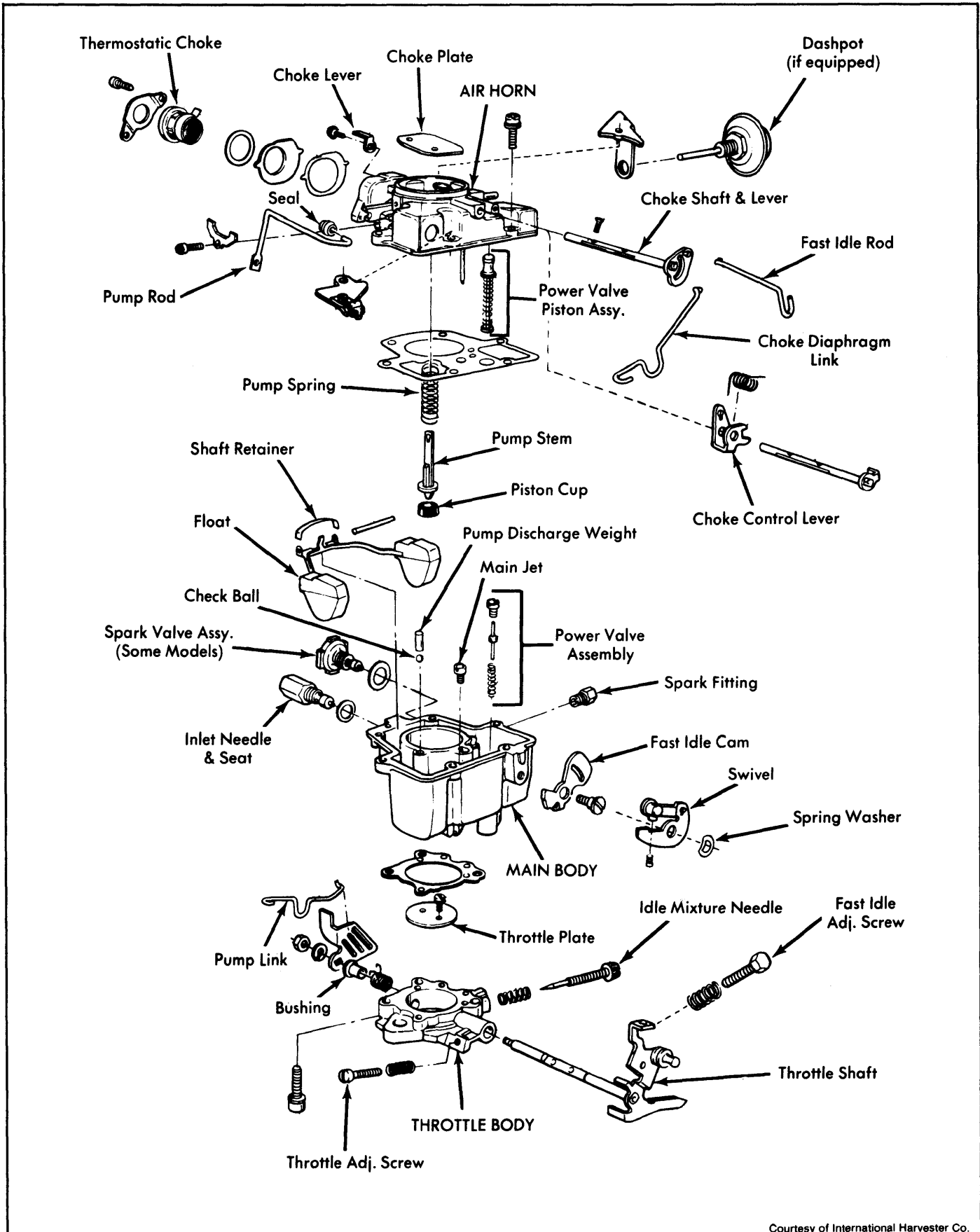

Courtesy of International Harvester Co.

Fig. 5: Exploded View of Holley 1940 Carburetor

1975-79 FUEL SYSTEMS

Holley 1940 1-Barrel Carburetor (Cont.)

1975 CARBURETOR ADJUSTMENT SPECIFICATIONS							
Holley Carb. No.	Idle Speed (Engine RPM)		Accel. Pump Setting	Float Setting	Fast Idle Cam Setting	Vacuum Kick Setting	Choke Unloader Setting
	Hot	Fast					
7161	525-575	2000	$\frac{25}{32}$ "	①235-.295"

① — Flush with top edge of bowl with inlet valve held closed.

1976 CARBURETOR ADJUSTMENT SPECIFICATIONS							
Holley Carb. No.	Idle Speed (Engine RPM)		Accel. Pump Setting	Float Setting	Fast Idle Cam Setting	Vacuum Kick Setting	Choke Unloader Setting
	Hot	Fast					
R7161A	525-575	2000	$\frac{25}{32}$ "	①235-.295"

① — Flush with top edge of bowl with inlet valve held closed.

1977 CARBURETOR ADJUSTMENT SPECIFICATIONS							
Holley Carb. No.	Idle Speed (Engine RPM)		Accel. Pump Setting	Float Setting	Fast Idle Cam Setting	Vacuum Kick Setting	Choke Unloader Setting
	Hot	Fast					
R7161A	525-575	2000	.781"	①	.115-.145"	.100-.130"	.235-.295"
R7576A	525-575	2000	.781"	①	.115-.145"	.100-.130"	.235-.295"

① — Toe of floats flush with upper edge of fuel bowl with inlet valve held closed

1978 CARBURETOR ADJUSTMENT SPECIFICATIONS							
Holley Carb. No.	Idle Speed (Engine RPM)		Accel. Pump Setting	Float Setting	Fast Idle Cam Setting	Vacuum Kick Setting	Choke Unloader Setting
	Hot	Fast					
7161	525-575	2000	.781"	①	.115-.145"	.100-.130"	.235-.295"
7576	525-575	2000	.781"	①	.115-.145"	.100-.130"	.235-.295"
8239	525-575	2000	.781"	①	.115-.145"	.100-.130"	.235-.295"

① — Toe of floats flush with upper edge of fuel bowl with inlet valve held closed.

1979 CARBURETOR ADJUSTMENT SPECIFICATIONS						
Application	Float Level Setting	Fuel Level Setting	Accel. Pump Stroke Setting	Fast Idle Cam Setting	Choke Unloader Setting	Auto. Choke Setting
7771	①	$\frac{11}{16} \pm \frac{1}{32}$ "	$\frac{25}{32}$ "	.150-.180"	.235"-.295"	1NL

① — See Adjustment Procedure.